

**An Assessment of Honeybee Foraging Activity and Pollination Efficacy  
in Australian Bt Cotton**

A Dissertation  
by

**MARWAN MOHAMED KESHLAF**

**Presented in fulfilment of the requirements for the degree of  
DOCTOR OF PHILOSOPHY**

CENTRE FOR PLANT AND FOOD SCIENCES  
UNIVERSITY OF WESTERN SYDNEY  
AUSTRALIA

**July 2008**

## **DEDICATION**

**To my wife, my parents, my son Elyas and daughters Islam and Safeea,  
for their sacrifices, prayers, and constant support and encouragement.**

## **DECLARATION**

I declare that this thesis submitted is wholly my own work unless otherwise referenced or acknowledged. The document has not been submitted for qualifications at any other academic institution.



**Marwan M. Keshlaf**

**3 July 2008**

## ACKNOWLEDGMENTS

I wish to express my sincere appreciation to my supervisors, Professor Robert Spooner-Hart and Dr. Robert Mensah, for their generous guidance, advice and support. I am especially grateful to Professor R. Spooner-Hart who clarified my ideas, and helped me to improve my writing skills.

I am very grateful to Professor Andrew Beattie for his comments and valuable suggestion in the thesis. I would like to express my sincere gratitude to Dr. Albert Basta for supervising the bioassay experiments. Also, the assistance provided by UWS staff, Oleg Nicetic for his advice and statistical analysis, Liz Kabanoff for providing pollen SEM, Mr. Michael Duncan for bee management is greatly appreciated. Special thanks are given to Dr Michael Batley, from the Australian Museum of Natural History, Sydney, for insect identification.

I am thankful to Australian Cotton Research Institute (ACRI) for providing their cotton fields, use of its research facilities, and processing yield measurements and ELISA test. Special thanks to Leah Austin and Raymond Morphew, employees at Narrabri (ACRI), for technical assistance.

I thank Mr. Warren Jones, who provided all beehives and equipment during the research period; also his experience in crop pollination in Australia was useful for me.

I also thank Al-Fateh University, Tripoli, Libya for the scholarship, and finally, I wish to thank my parents and family for their support and understanding.

## TABLE OF CONTENTS

	<u>Page</u>
<b>DEDICATION</b> .....	ii
<b>DECLARATION</b> .....	iii
<b>ACKNOWLEDGMENTS</b> .....	iv
<b>TABLE OF CONTENTS</b> .....	v
<b>LIST OF TABLES</b>	xi
<b>LIST OF FIGURES</b>	xiii
<b>SUMMARY</b> .....	xvi
<b><u>CHAPTER 1. GENERAL LITERATURE REVIEW</u></b>	
<b>1.1 Introduction</b> .....	1
<b>1.2 Phenology of cotton</b> .....	4
1.2.1 The cotton plant .....	4
1.2.2 Flowering and bolls .....	4
1.2.3 The flowering pattern .....	6
1.2.4 Floral biology .....	7
1.2.5 Nectar and nectary glands .....	7
<b>1.3 Cotton pollination</b> .....	9
1.3.1 Pollination ecology .....	9
1.3.2 Pollinating agents .....	13
1.3.3 The role of honeybees as pollinating agent in cotton .....	15
<b>1.4 Management of honeybee colonies during the pollination season</b> .....	18
1.4.1 The stocking rate .....	18
1.4.2 Scheduling the arrival and removal of honeybee colonies, in relation to the target crop .....	20
1.4.3 The spatial distribution of colonies in relation to the target crop area .....	21
<b>1.5 Honeybee foraging behaviour in cotton flowers</b> .....	22
1.5.1 Pollen gathering activity .....	24
1.5.2 Nectar gathering activity .....	27
1.5.3 Cotton as a honey plant .....	28
1.5.4 Attractiveness of flowering cotton plants .....	30
<b>1.6 Techniques used to increase activity of honeybees, and their pollination     efficacy</b> .....	31
1.6.1 The use of pollen trap to increase bee activity .....	31
1.6.2 Provision of supplementary food and its effect on bee activity .....	34

1.6.3 Use of pollination enhancement chemical on bee activity and pollination	35
<b>1.7 The role of beetles in pollination</b>	38
<b>1.8 Hazardous effects of insecticides on cotton pollination</b>	40
<b>1.9 Transgenic (Bt) cotton</b>	44
<b>1.10 Thesis objectives</b>	46
<b><u>CHAPTER 2. EFFECT OF TRAPPING POLLEN, AND FEEDING POLLEN SUPPLEMENTS, TO HONEYBEE COLONIES USED FOR COTTON POLLINATION</u></b>	
<b>2.1 Introduction</b>	48
<b>2.2 Materials and Methods</b>	50
2.2.1 Location	50
2.2.2 Treatments	51
2.2.3 Flight activity	53
2.2.4 Pollen gathering activity	54
2.2.4.1 Trapping pollen	54
2.2.4.4 Area of stored pollen	56
2.2.5 Brood rearing activity	57
2.2.6 Nectar gathering activity	58
2.2.7 Honeybee pollination efficacy	59
2.2.7.1 Foraging activity of honeybee visitors to cotton flowers	59
2.2.7.2 Cotton yield measurements	60
2.2.8 Determination of the cotton flowering pattern	62
2.2.9 Determination of other species flowering within the experimental area	62
2.2.10 Recording of meteorological conditions during investigation period	62
2.2.11 Statistical analysis	62
<b>2.3 Results</b>	63
2.3.1 Influence of provision of supplementary pollen on honeybee activity	63
2.3.1.3 Flight activity	63
2.3.1.4 Pollen gathering activity	65
2.3.1.5 Brood rearing activity	67
2.3.1.6 Nectar gathering activity	68
2.3.2 Influence of restricting pollen entry to colonies (by using pollen trap) on honeybee activity	68
2.3.2.1 Flight activity	68
2.3.2.2 Pollen gathering activity	69
2.3.2.3 Brood rearing activity	75

2.3.2.4 Nectar gathering activity .....	76
2.3.3 General flight activity .....	76
2.3.3.1 Diurnal flight activity .....	76
2.3.3.2 Weekly flight activity .....	77
2.3.4 Bee pollination efficacy .....	77
2.3.4.1 Foraging activity of honeybee visitors to cotton flowers .....	77
2.3.4.2 Non- <i>Apis</i> pollinators .....	80
2.3.4.3 Cotton yield measurements .....	80
2.3.5 Determination of the cotton flowering pattern .....	81
2.3.6 Determination of other species flowering within the experimental area ...	82
2.3.7 Temperature and humidity during the experimental period .....	82
<b>2.4 Discussion</b> .....	<b>83</b>
2.4.1 Influence of provision of supplementary pollen on honeybee activity .....	83
2.4.2 Influence of restricting pollen entry to colonies (by use of pollen traps) on honeybee activity .....	87
2.4.3 Bee pollination efficacy .....	94
<b>2.5 Conclusions</b> .....	<b>98</b>
<b><u>CHAPTER 3. THE EFFECT OF SYNTHETIC QUEEN MANDIBULAR PHERMONE ON HONEYBEE FORAGING ACTIVITY IN COTTON FLOWERS, AND SUBSEQUENT EFFECTS ON YIELD AND QUALITY</u></b>	
<b>3.1 Introduction</b> .....	<b>100</b>
<b>3.2 Materials and methods</b> .....	<b>103</b>
3.2.1 Location .....	103
3.2.2 Treatment .....	103
3.2.3 Assessment of bee activity .....	104
3.2.4 Percentage boll set .....	105
3.2.5 Assessment of cotton yield .....	105
3.2.6 Recording meteorological conditions during investigation period .....	106
3.2.7 Statistical analysis .....	106
<b>3.3 Results</b> .....	<b>106</b>
3.3.1 Assessment of bee activity .....	106
3.3.2 Percentage boll set .....	108
3.3.3 Assessment of cotton yield quality and quantity.....	109
3.2.4 Temperature and humidity during the experimental period .....	111
<b>3.4 Discussion</b> .....	<b>112</b>
<b>3.5 Conclusions</b> .....	<b>116</b>

**CHAPTER 4. HONEYBEE FIELD ACTIVITY, POLLINATION EFFECTIVENESS AND INFLUENCE ON YIELD PARAMETERS IN TRANSGENIC BT COTTON**

<b>4.1 Introduction</b> .....	118
<b>4.2 Materials and methods</b> .....	120
4.2.1 Location .....	120
4.2.2 Honeybee pollination efficacy .....	121
4.2.2.1 Treatments .....	121
4.2.2.2 Assessment of honeybee foraging activity .....	123
4.2.2.3 Cotton yield measurements .....	125
4.3.2 Cotton gene flow .....	125
4.2.3.1 Experimental design .....	125
4.2.3.2 Sampling and testing protocol .....	126
4.2.4 Recording meteorological conditions during investigation period .....	126
4.2.5 Statistical analysis .....	126
<b>4.3 Results</b> .....	127
4.3.1 Honeybee pollination efficacy .....	127
4.3.2 Cotton yield measurements .....	132
4.3.3 Cotton floral phenology .....	134
4.3.4 Cotton gene flow .....	134
4.3.5 Temperature and humidity during experimental period .....	134
<b>4.4 Discussion</b> .....	135
4.4.1 Honeybee pollination efficacy .....	135
4.4.2 Honeybee foraging activity .....	137
4.4.3 Cotton yield measurements .....	140
4.4.4 Cotton gene flow .....	141
<b>4.5 Conclusions</b> .....	142

**CHAPTER 5. THE ROLE OF POLLEN BEETLES IN COTTON POLLINATION, AND THEIR EFFECTS ON THE FORAGING BEHAVIOUR OF HONEYBEES**

<b>5.1 Introduction</b> .....	144
<b>5.2 Materials and methods</b> .....	147
5.2.1 Location .....	147
5.2.2 Abundance of pollen beetles .....	147
5.2.3 Foraging behaviour of pollen beetles .....	148
5.2.4 Pollination efficacy of pollen beetles .....	148



5.2.4.1	Cage experiment .....	148
5.2.4.2	Bagged flower experiment .....	149
5.2.5	The effects of pollen beetles on honeybee visits to cotton flowers .....	151
5.2.6	Recording meteorological conditions during investigation period .....	152
5.2.7	Statistical analysis .....	152
<b>5.3</b>	<b>Results</b> .....	152
5.3.1	Abundance of pollen beetles .....	152
5.3.2	Foraging behaviour of pollen beetles .....	153
5.3.3	Pollination efficacy of pollen beetles .....	155
5.3.3.1	Cage experiment .....	155
5.3.3.2	Bagged flower experiment .....	157
5.3.4	The effects of pollen beetles on honeybee visits to cotton flowers .....	158
<b>5.4</b>	<b>Discussion</b> .....	162
5.4.1	Abundance of pollen beetles .....	162
5.4.2	Attractiveness of cotton flowers to pollen beetles .....	163
5.4.3	Pollen beetles behaviour in cotton flowers .....	164
5.4.4	Pollination efficacy of pollen beetles .....	165
5.4.5	Detrimental effects of pollen beetles .....	166
5.4.6	Deterrence of honeybees by pollen beetles .....	168
<b>5.5</b>	<b>Conclusions</b> .....	169
<b><u>CHAPTER 6. ASSESSMENT OF TOXICITY OF FIPRONIL AND ITS RESIDUES TO HONEYBEES</u></b>		
<b>6.1</b>	<b>Introduction</b> .....	170
<b>6.2</b>	<b>Materials and methods</b> .....	173
6.2.1	Honeybee samples .....	173
6.2.2	Bioassay techniques .....	173
6.2.2.1	Topical acute toxicity of fipronil to honeybees .....	174
6.2.2.2	Oral acute toxicity of fipronil to honeybees .....	175
6.2.2.3	Bioassay of fipronil residues .....	176
6.2.3	Statistical analysis .....	181
<b>6.3</b>	<b>Results</b> .....	182
6.3.1	Topical acute toxicity of fipronil to honeybees .....	182
6.3.2	Oral acute toxicity of fipronil to honeybees .....	182
6.3.3	Bioassay of fipronil residues .....	183
<b>6.4</b>	<b>Discussion</b> .....	188

<b>6.5 Conclusions .....</b>	<b>192</b>
<b><u>CHAPTER 7. GENERAL DISCUSSION</u></b>	
<b>7.1 General discussion .....</b>	<b>193</b>
<b>7.2 Future work .....</b>	<b>204</b>
<b>7.3 Final conclusion .....</b>	<b>205</b>
<b>REFERENCES .....</b>	<b>206</b>
<b>Appendix I. ELISA testing procedure for Cry1Ac and Cry1Ac genes.....</b>	<b>235</b>
<b>Appendix II. Incoming-bee trap.....</b>	<b>239</b>

## LIST OF TABLES

## Page

1.1 Major cotton growing countries, their extent and their contribution to the world market, 2007-2008.....	2
1.2 Measurements of cotton lint parameters used to determine the grade of cotton quality.....	13
1.3 Published stocking rates of honeybee colonies in cotton fields, and their associated visitation rates to cotton flowers.....	19
1.4 Average number of sprays of various pesticides on Australian conventional and transgenic (Ingard <sup>®</sup> , Bollgard <sup>®</sup> II) cotton, during seasons 2003, 2004 and 2005.....	43
2.1 The major sources of trapped pollen (g) collected by honeybees, pollen pellet colour, average weight, and size of grains.....	73
2.2 Cotton yield parameters from cotton plants in caged and open plots at ACRI, 2005 (n = 4; 2 mixed samples / replicate).....	81
2.3 Non- <i>Gossypium</i> flowering plants near the experimental field which were visited by honeybee foragers.....	82
3.1 Effect of application of different doses of synthetic queen mandibular gland pheromone Fruit Boost <sup>®</sup> on honeybee foraging activity on cotton flowers.....	107
3.2 Proportion of pollinating and non-pollinating honeybees visiting cotton flowers treated with different doses of Fruit Boost <sup>®</sup> .....	108
3.3 Pollinating (infloral) honeybee visitation to cotton flowers and subsequent boll set, following applications of different doses of Fruit Boost <sup>®</sup> .....	109
3.4 Effect of application of different doses of synthetic queen mandibular gland pheromone Fruit Boost <sup>®</sup> on cotton yield parameters.....	110
3.5 Effect of application of different doses of Fruit Boost <sup>®</sup> on cotton lint quality parameters (mean fibre length, length uniformity, strength, and micronaire) measured using High Volume Instrument (HVI).....	111
4.1 The relationship between number of cotton flowers, number of out-going bees and number of bees recorded on cotton flowers (season 2006-07).....	128
4.2 Effect of different pollination treatments NB: No access to honeybees, TB: temporary access to honeybees (caged for middle ten days), OB: open access to field honeybees for entire investigation period, on cotton yield parameters.....	133
4.3 Effect of different pollination treatments on cotton parameters of lint quality: micronaire, strength, length, and uniformity. Treatments are NB: No access to bees, TB: temporary access to bees, and OB: open access to bees, at ACRI, 2007.....	134
5.1 Effect of pollen beetles, <i>C. aterrimus</i> , on cotton yield parameters under caged (with/out beetles) and uncaged plants at ACRI, 2007.....	156

<b>5.2</b> Effect of pollen beetles, <i>C. aterrimus</i> , on lint quality parameters (mean length, length uniformity, strength, and micronaire measured using HVI) for bolls collected from caged (with/out beetles) and uncaged cotton plants.....	157
<b>5.3</b> Effect of pollen beetles, <i>C. aterrimus</i> , on cotton yield parameters from bagged (with/out beetles) and unbagged cotton flowers at ACRI, 2007.....	158
<b>5.4</b> Effect of pollen beetles <i>C. aterrimus</i> on lint quality parameters (mean length,length uniformity, strength, and micronaire measured using HVI) for bolls collected from bagged (with/out beetles) and unbagged cotton flowers.....	158
<b>6.1</b> Statistical summary of results for acute toxicity of topically applied fipronil (1 µl) to seven-day old <i>A. mellifera</i> workers, after 24 h.....	182
<b>6.2</b> Statistical summary of results for oral toxicity of honey syrup containing fipronil to seven-day old <i>A. mellifera</i> workers, after 24 h.....	183
<b>6.3</b> Statistical summary of results for time to reach 50% mortality of <i>A. mellifera</i> workers when exposed to various age fipronil residues, at a number of exposure periods .....	185
<b>6.4</b> Statistical summary of results for time to reach 90% mortality for <i>A. mellifera</i> workers when exposed to various age fipronil residues, at a number of exposure periods.....	185
<b>6.5</b> The percentage of bee mortality after exposing them to residues of field rates of fipronil, periodically (3 h) or continuously (24 h), after 24 h.....	186

## LIST OF FIGURES

	<u>Page</u>
1.1 Map of major cotton growing areas in Australia.....	3
1.2 Typical seasonal development of cotton in the U.S Cotton Belt showing the production of squares, bolls and open bolls.....	5
1.3 Upland cotton flower on morning of anthesis: A dissected flower enlarged to show construction.....	6
2.2 Portable wire cloth cone for counting honeybees as they fly out from a colony	54
2.2 Photographed frame of <i>A. mellifera</i> used to assess the area occupied by sealed brood (with trace line).....	58
2.3 Experimental design of the 2 ha field investigation site, with location of eight caged and eight open plots used to assess the pollination efficacy of honeybees, and 27 plots (15 m long) used to determine bee visitation rates to cotton flowers	60
2.4 Mean honeybee flight activity (number of out-going bees /30 sec /colony) in colonies fed weekly with 500 g pollen supplement patties and unfed (control) colonies.....	64
2.5 Mean weight of trapped pollen (g) from colonies fed weekly with 500 g pollen supplement patties and unfed (control) colonies (n=4), during the investigation period 5-30/3/2005.....	65
2.6 Mean area of stored pollen (cm <sup>2</sup> ) in colonies fed weekly with 500 g pollen supplement patties and unfed (control) colonies.....	66
2.7 Mean area of sealed brood in honeybee colonies fed weekly with 500 g pollen supplement patties and unfed (control) colonies.....	67
2.8 Mean bee flight activity (number of out-going bees / 30 seconds / colony) in colonies fitted with pollen trap and control (un-trapped) colonies (n= 8) on 9 and 14 March, 2005.....	69
2.9 Mean weight of trapped pollen (g) in colonies fitted with 30% efficient pollen traps (n = 8) during the investigation period 05-30/3/2005.....	70
2.10 SEM images showing the morphology of the major trapped pollen types collected from the experimental colonies, Narrabri, 2005.....	71
2.11 SEM images showing the large relative size and spines of cotton pollen grain, compared to other honeybee-collected pollen.....	72
2.12 Mean areas of stored pollen in colonies installed on 30% efficient pollen trap and control (un-trapped) colonies over the investigation period.....	74
2.13 Mean areas of sealed brood at approximately 12 day intervals in colonies fitted with 30% efficient pollen traps and control (un-trapped) colonies.....	75
2.14 Diurnal honeybee flight activity (mean number of out-going bees / 30 sec / colony) in untreated control colonies during the investigation period.....	76
2.15 Bee visitation rate (number of pollinating bees / 100 flowers) to cotton flowers during investigation period.....	78

<b>2.16</b> Diurnal bee visitations to cotton flowers (total number of bees visiting cotton flowers) during the investigation period.....	79
<b>2.17</b> Flowering pattern of cotton plants (mean number of flowers / 15 m plot) during the investigation period.....	81
<b>2.18</b> Minimum, maximum and average temperature, and relative humidity recorded at the experimental site during investigation period (5-30 March, 2005)	83
<b>3.1</b> Diurnal temperatures (°C) and relative humidity (% RH), from 07:00 to 19:00, at the study site during the 4 d experimental period, February 2006.....	111
<b>3.1</b> Experimental design of the 2 ha field site, caged (NB): Temporarily cage (TB): open plots (OB) used to assess the pollination efficacy of honeybees, and 30 plots (10 m long) used to determine bee visitation rate to cotton flowers during the investigation period.....	122
<b>4.2</b> Honeybee, <i>Apis mellifera</i> L., visitation rate (number of pollinating bees / 100 flowers) monitored on cotton flowers during the investigation period.....	128
<b>4.3</b> Honeybee foraging activity (collecting nectar or pollen) in cotton flowers at peak field foraging activity.....	129
<b>4.4</b> Scanning electron micrographs (SEM) of a pellet of cotton pollen collected by a pollen gathering bee.....	131
<b>4.6</b> Minimum, maximum and average temperatures, average of relative humidity recorded at the experimental site during investigation period.....	135
<b>5.1</b> Assessment of the pollination efficacy of pollen beetles by bagging cotton flowers with: a. no insects; b. 3 pollen beetles; c. 10 pollen beetles; d unbagged (exposed to pollen beetles and honeybees).....	151
<b>5.2</b> Pollen beetle, <i>C. aterrimus</i> , abundance in Plot 1 from 2 January to 5 February and in Plot 2, from 15 January to 14 February 2007.....	153
<b>5.3</b> Cotton flower occupied by more than 20 pollen beetles, located on the anthers and close to floral nectaries.....	154
<b>5.4</b> Cotton flowers showing signs of damage by high numbers of occupying pollen beetles, (a) and (b) damaged flowers, (c) un-infested flower.....	155
<b>5.5</b> A honeybee forager landed on a petal, and inspecting the flower cautiously so as to avoid pollen beetles.....	159
<b>5.6</b> Honeybee forager collecting floral nectar from outside a flower infested with <i>C. aterrimus</i> : this may be a form of avoidance behaviour.....	159
<b>5.7</b> The effect of <i>C. aterrimus</i> presence in flowers on the number of infloral visits by nectar-gathering bees, during the period 29 Jan to 14 Feb 2007.....	160
<b>5.8</b> The effect of <i>C. aterrimus</i> presence in flowers on the number of floral visits by pollen-gathering bees.....	161
<b>6.1</b> Structure of fipronil.....	172
<b>6.2</b> Experimental setup for assessing toxicity to honeybees of fipronil residues on cotton foliage exposed to normal weather conditions.....	180

<b>6.3</b> Close-up of one of the experimental Petri dishes (with two circular holes) used for assessing toxicity to honeybees of fipronil residues on cotton foliage.....	181
<b>6.4</b> Estimated regression lines and their 95% CL for time (h) for death of honeybees continuously exposed to 1 ppm and 10 ppm a.i. (w/v) fresh residues of fipronil.....	184
<b>6.5</b> Mortality of honeybees, after 3 h exposure to aged residues of half rate fipronil, on cotton leaves (mortality recorded 24 h after commencement of exposure).....	187
<b>6.6</b> Mortality of honeybees, after 3 h exposure to aged residues of full rate fipronil, on cotton leaves (mortality recorded 24 h after commencement of exposure).....	187

## SUMMARY

Cotton is a high-value commercial crop in Australia. Although cotton is largely self-pollinating, previous researchers have reported that honeybees, *Apis mellifera*, can assist in cross-pollination and contribute to improved yield. Until recently, use of bees in cotton had, however, been greatly limited by excessive use of pesticides to control arthropod pests. With the widespread use of transgenic (Bt) cotton varieties and the associated reduction in pesticide use, I decided to investigate the role and importance of honeybees in Bt cotton, under Australian conditions.

I conducted two major field trials at Narrabri, in the centre of one of Australia's major cotton-growing areas, in the 2005-6 and 2006-7 seasons. In the first trial, I particularly assessed methods of manipulating honeybee colonies by feeding pollen supplements of pollen/soybean patties, and by restricting pollen influx by the fitting of 30% efficient pollen traps. I aimed to test whether either of these strategies increased honeybee flight activity and, thus, increased foraging on cotton flowers.

My results showed that although supplementary feeding increased bee flight activity and brood production, it did not increase pollen collection on cotton. Pollen traps initially reduced flight activity. They also reduced the amount of pollen stored in colonies, slowed down brood rearing activity, and honey production. However, they did not contribute to increased pollen collection in cotton.

In the second trial, I spent more time investigating honeybee behaviour in cotton as well as assessing the effect of providing flowering cotton plants with access to honeybees for different time periods (e.g. 25 d, 15 d, 0 d). In this year, I used double the hive stocking rate of (16 colonies / ha) than in the previous year, because in 2005-6 I observed few bees in cotton flowers. I also conducted a preliminary investigation to assess whether there was any gene flow over a 16 m distance from Bt cotton to conventional cotton, in the presence of a relatively high honeybee population.



Both of my field experiments showed that honeybees significantly increased cotton yield via increased boll set, mean weight of bolls, number of seeds / boll, and weight of lint / boll. It was obvious that cotton flowers, and particularly cotton pollen, were not attractive to honeybees, and this was also reflected in the low proportion (5.3% w/w) of pollen from cotton collected in the pollen traps. However, flower visitation rate was generally above the 0.5% level regarded as optimal for cross-pollination in cotton, and this was reflected in increased yield parameters.

I recorded a gene flow of 1.7 % from Bollgard<sup>®</sup> II cotton to conventional cotton, over a distance of 16 m. This is much higher than had previously been reported for Australia, and may have been a result of high honeybee numbers in the vicinity, associated with my managed hives.

In an attempt to attract more honeybees to cotton flowers, I conducted an investigation where I applied synthetic Queen Mandibular Pheromone (QMP) (Fruit Boost<sup>®</sup>) at two rates, 50 QEQ and 500 QEQ / ha, and for two applications, 2 d apart. Neither rate of QMP increased the level of bee visitation to flowers, either on the day of application or the subsequent day. There was also no increase in boll set or yield in plants treated with QMP.

My observations of honeybee behaviour in cotton brought some interesting findings. First, honeybees totally ignored extrafloral nectaries. Second, most flower-visiting honeybees collected nectar, but the overwhelming majority of them (84%) collected floral nectar from outside flowers: this meant these bees did not contribute to pollination. Those nectar gatherers which entered flowers did contribute to pollination. However, they were observed to exhibit rejection of cotton pollen by scraping pollen grains from their body and discarding them, prior to returning to their hives. Pollen gatherers collected only small, loose pellets from cotton.

SEM studies showed that cotton pollen grains were the largest of all pollen commonly collected by bees in my investigations, and that they also had large spines. It is likely that these characteristics make cotton pollen unattractive to honeybees.

Another possible reason for the unattractiveness of cotton flowers was the presence of pollen beetles, *Carpophilus aterrimus*, in them. I conducted a series of studies to determine the role of pollen beetles in pollination of cotton. I found that they did not contribute to pollination at low levels; at high populations they damaged flowers (with  $\geq 10$  beetles / flower, no flowers set bolls); and that honeybees, when given the choice, avoid flowers with pollen beetles.

Because the insecticide fipronil was commonly used in Australian cotton at flowering time, and because I had some experience of its toxic effects against honeybees in my field investigations, I conducted a series of laboratory and potted plant bioassays, using young worker bees. The studies confirmed its highly toxic nature. I recorded an acute dermal LD<sub>50</sub> of 1.9 ng / bee, and an acute oral LC<sub>50</sub> of 0.62 ppm. Fipronil's residual toxicity also remained high for an extended period in both laboratory and potted plant trials. For example, when applied to cotton leaves in weather-exposed potted cotton plants, it took 25 d and 20 d for full and half recommended rates of fipronil, respectively, to become non-toxic to honeybees.

I had previously investigated whether a shorter period of exposure of cotton plants to honeybees would contribute adequately to increased yield, and concluded that a 10 d window within a 25 d flowering period would contribute 55% of the increase in total weight of bolls contributable to honeybee pollination, but only 36% of the increase in weight of lint. Given the highly residual activity of fipronil I recorded, the only opportunity for an insecticide-free period during flowering would be at its commencement.

I concluded that, while there is evidence that honeybees can contribute to increased cotton yield in Bt cotton in Australia, this is unlikely with the continued use of fipronil at flowering.

# CHAPTER 1

## GENERAL LITERATURE REVIEW

### 1.1 INTRODUCTION

Cotton, *Gossypium* spp. (Malvales: Malvaceae), is considered the world's most important fibre crop (Percival *et al.*, 1999; Wendel *et al.*, 1992) and the second most important oil seed crop (Jenkins & Suha, 2001). Cotton is currently grown successfully in many countries around the world and a number of them make significant contributions to the total world production (Table 1.1). It is grown primarily for its lint, which accounts for over 95% of the total crop value (Stephanie *et al.*, 2003). The seed is used for planting or is crushed for oil, with the residue used as livestock food (McGregor, 1976). Although cotton seed is rich in oil and protein, it also contains gossypol, a polyphenolic compound that is toxic to humans and animals, and is why the use of cotton seed for feedstuffs is restricted (Lusas & Jividen, 1987).

The most commonly cultivated species of cotton are upland cotton, *G. hirsutum* L., Egyptian cotton, "Pima", *G. barbadense* L., Asiatic cotton, *G. herbaceum* L., and tree cotton, *G. arboretum* L. (Free, 1993). Currently, *G. hirsutum* is the species that dominates world cotton cultivation and provides over 90% of the annual cotton crop. It has spread from its original home in Meso-America and is grown from 37°N, in the United States, to 32°S, in Australia and South America (Niles & Feaster, 1984).

Australian production of cotton has continued to rise over the 40 year period from nearly zero in 1960 to more than three million bales in 2000 (Constable *et al.*, 2001). The cotton industry has been one of the fastest growing sectors in Australian agriculture because cotton production is seen to be more profitable than many other farm enterprises such as wheat, wool and beef, even though water availability may constrain growth in some regions (Anon, 1999). Australia also has an intensive cotton production system that has the highest average yield per hectare (2,027 kg / ha) (Anon, 2008a) with a similar high

lint quality as American and Egyptian cotton (Eveleigh *et al.*, 1999). Although a relatively small producer, more than 90 per cent of Australia's cotton production is exported, with the majority destined for Asia (Chang & Nguyen, 2002), making it the fifth largest exporter in the world in recent years (Table 1.1). Currently, the total cotton production in Australia contributes around A\$ 1.14 billion to the world market (Anon, 2007a).

**Table 2.1 Major cotton growing countries, their extent and their contribution to the world market, 2007-2008** [Source: U.S. Department of Agriculture (2008a)].

Country	Production			Area (ha) ×1000	Export Metric Tonnes ×1000
	Metric Tonnes ×1000	Lint kg / ha	Yield		
China	7,795	1,257		6,200	-
India	5,508	578		9,530	1,372
USA	4,182	985		4,250	3,026
Pakistan	1,938	646		3,000	-
Brazil	1,557	1,428		1,090	501
Uzbekistan	1,197	826		1,450	969
Turkey	697	1,222		570	-
Australia	139	1,742		80	261
Subtotal (%)	23,130(88.5%)			26,170 (78.5)	6,129 (73.4%)

Cotton in Australia is primarily grown as an irrigated annual crop during summer along the eastern side of the continent, but production is constrained by available water and damage by insects (Llewellyn *et al.*, 2007). The Western Australia industry was situated on the Ord River in the tropical north of the state, but ceased production in 1974 due to the development of insecticide resistance in the bollworm, *Helicoverpa armigera* (Hübner), (Lepidoptera: Noctuidae), which is a key pest of cotton (Hearn, 1975). Despite the collapse of cotton production in Western Australia, production in the states of New

South Wales (NSW) and Queensland (Qld) has increased significantly in the last three decades (Constable *et al.*, 2001).

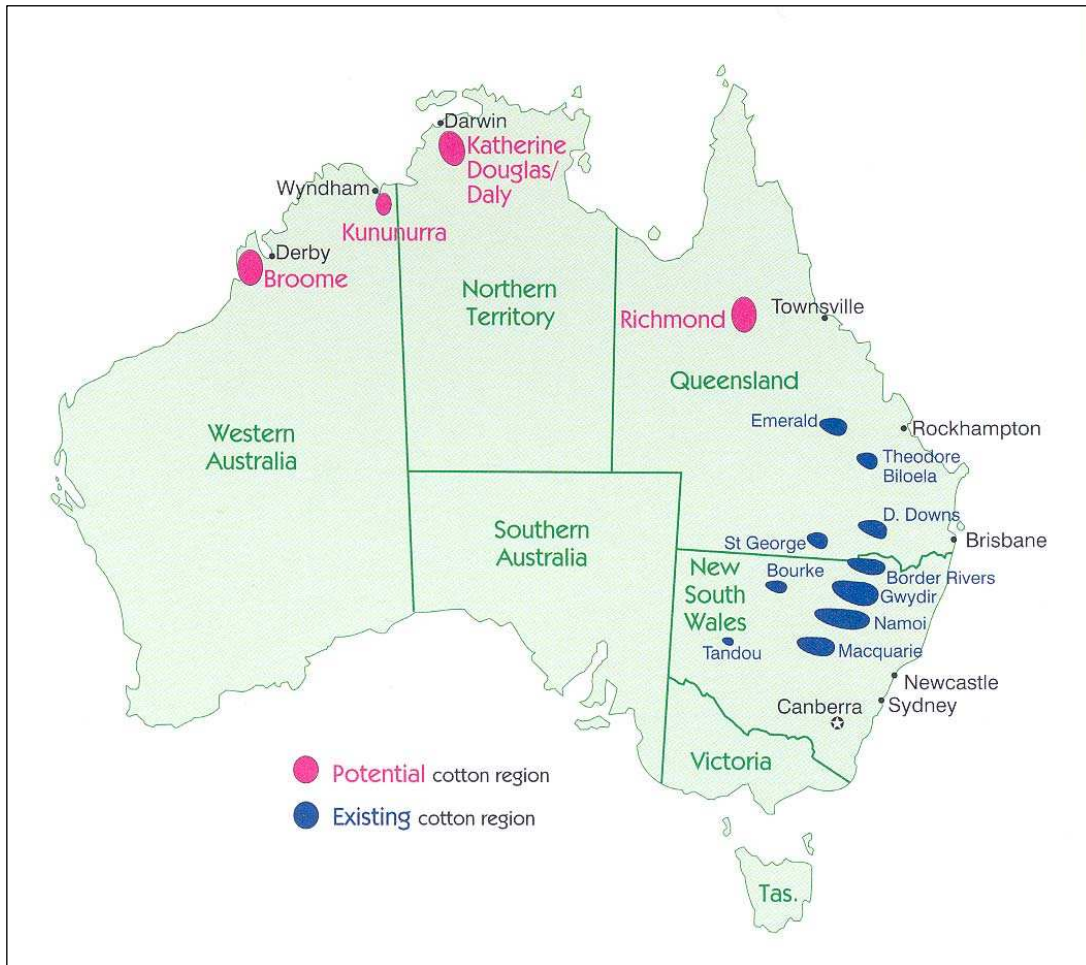

**Figure 3.1 Map of major cotton growing areas in Australia [Source: Constable *et al.* (2001)].**

Cotton growers in NSW are concentrated in the Gwydir, Namoi and Macquarie valleys as well as areas along the Darling and Barwon Rivers (Figure 1.1). In Qld, the major cotton growing areas include the Darling Downs, St. George, Dirranbandi, Macintyre Valley, Emerald, Theodore and Biloela (Figure 1.1). Because of drought conditions, the total area planted to cotton in Australia decreased from 0.34 Million hectares (M ha) in 2006, to 0.15 M ha in 2007, to 0.08 M ha in 2008. Also, during this time, the mean yield decreased from 2,027 to 1,742 kg / ha, which is still the world's highest (Anon, 2008a).

## ***1.2 PHENOLOGY OF COTTON***

The growth, structure, and development patterns of the cotton plant have been detailed in a number of publications (Brown & Ware, 1958; Hector, 1963; Mauney, 1984; Oosterhuis, 1990; Oosterhuis & Jernstedt, 1999). Cotton plant physiology has been described by Eaton (1955) and Mauney & Stewart (1986). Plant development in cotton (Figure 1.2) proceeds through a number of stages: (1) germination and seedling establishment, (2) leaf area and canopy development, (3) flowering and boll development, and (4) boll maturation (Oosterhuis, 1990).

### ***1.2.1 The cotton plant***

Upland cotton plants are 0.6-1.5 m high (Clemson, 1985), with the shoot system being made up of a main axis stem, leaves, buds, branches and, ultimately, flower buds, flowers and fruit (bolls). Agronomically, main-stem leaves are predominant in the plant apex and thus serve an important role in light interception and as a primary target for oviposition by certain insects (Oosterhuis & Wullschleger, 1988).

### ***1.2.2 Flowering and bolls***

Reproductive growth commences about four to five weeks after planting with the formation of floral buds in the apical parts of the plant (Beasley, 1975). The reproductive stage is followed several weeks later by flower opening (anthesis) and the commencement of fruit (boll) development (Oosterhuis, 1990).

Floral buds first appear as small, green, pyramidal structures known as squares. A square is composed of three large bracts forming the epicalyx which completely enclose the developing flower. The flower is 5-10 cm long and 5 cm wide (Figure 1.3). It has five conspicuous petals, fused for most of their length to form the obliquely lobed calyx which tightly encloses the base of the petals (Delaplane & Mayer, 2000). Thus, the corolla appears polypetalous (distinct petals) but it is, in fact, sympetalous (petals fused at the base). The staminal column is composed of numerous filaments which are fused to the corolla and with each other along most of their length. Distinct filaments are exerted in pairs along the length of the staminal column, and each bears a two-lobed anther. The

staminal column surrounds the style that joins together with 2-5 lobed stigmas to constitute the female part of the flower. The ovary is superior and composed of 3-5 united carpels, each with several ovules. One carpel forms one locule (Smith & Cothren, 1999).

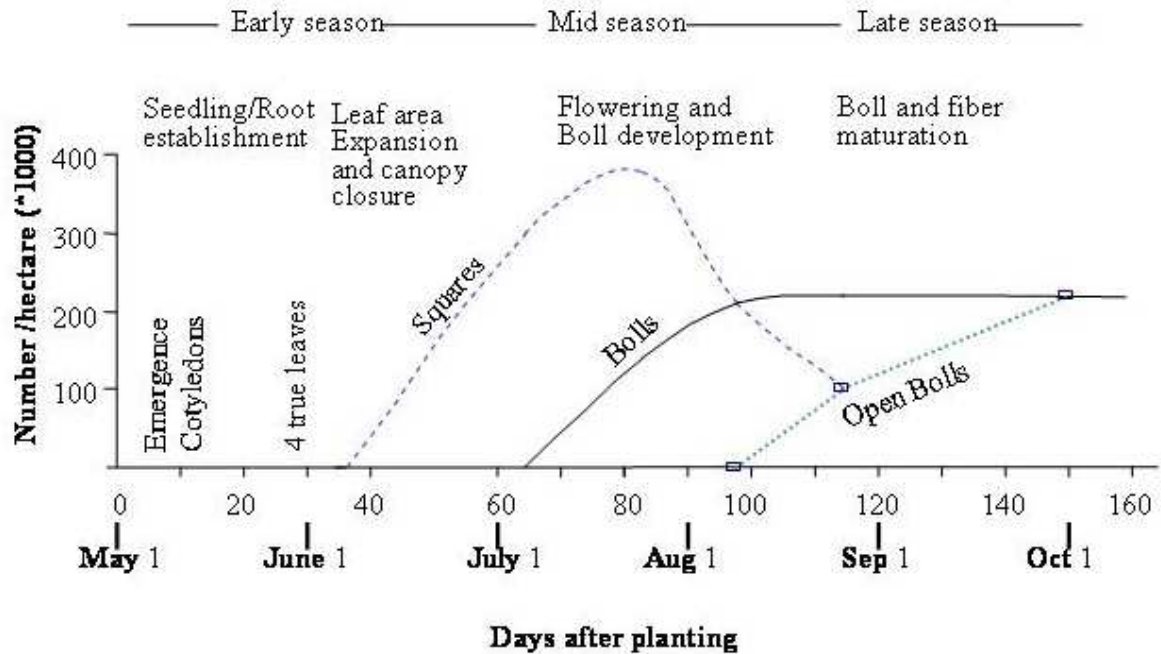

**Figure 1.2 Typical seasonal development of cotton in the U.S Cotton Belt showing the production of squares, bolls and open bolls [Source: Oosterhuis (1990)].**

Cotton ovaries exhibit axile placentation with two rows of ovules in each locule. Each locule contains some 8-15 ovules, the number of which varies with variety and growth conditions during flower development. However, not all of these ovules develop into mature seeds. Each locule contains an average of about eight seeds. Seeds are covered with large amounts of lint-like hairs (Clemson, 1985). Fruits are large, rounded capsules called “bolls” which are divided into 3-5 compartments. Each boll commonly contains 25-35 seeds. The number of pollen grains present on the stigma will determine the probability that the ovary matures into a ripe boll, and also the number of ovules which are fertilized and develop into seeds in the mature boll (Smith & Cothren, 1999).



### 1.2.3 *The flowering pattern*

Cotton has a distinctive and predictable flowering pattern (Figure 1.2). The first flowers to open are those at the base of the plant, usually at main-stem nodes 6 or 7, and at the first partition along a fruiting branch. Approximately three days elapse between the opening of a flower on a given fruiting branch and the opening of a flower at the same relative position on the next higher fruiting branch (this is known as the vertical flowering interval). On the other hand, the time interval for the development of two successive flowers on the same branch is about six days (the horizontal flowering interval). The order of flowering is thus spirally upwards and outwards. The cotton plant continues to grow and produce flowers until defoliation or being killed by frost (Smith & Cothren, 1999).

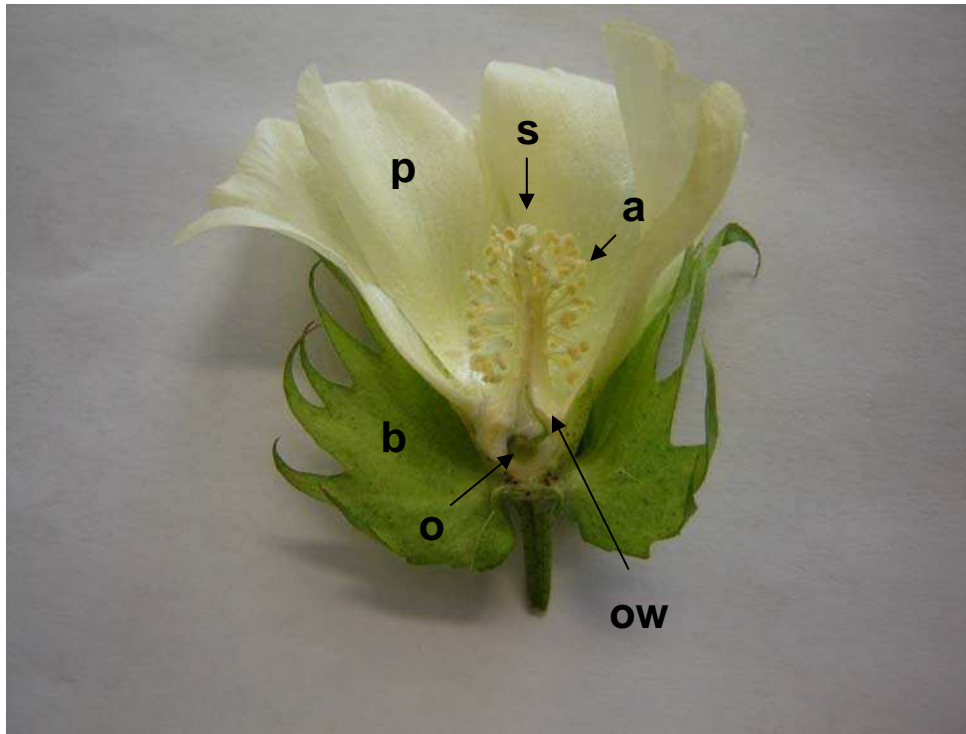

**Figure 1.3 Upland cotton flower on morning of anthesis:** A dissected flower enlarged to show construction. a. anthers; b. bracts; p. petals; s. stigma protruding slightly above the anthers; o. ovules and ow. ovary wall.

The shedding or abscission of squares and young bolls is a natural phenomenon in cotton that is accentuated by adverse environmental conditions, including extended overcast weather, extreme temperatures, water stress, mechanical injury, and certain genetic factors, diseases (Smith & Cothren, 1999) and pest insects (Khan & Bauer, 2002; Ward, 2005). In addition, inadequate pollination is considered a possible cause of flower shedding (Meade, 1918; McGregor, 1976). Occasionally, during periods of extreme heat, the cotton flower will fail to produce viable pollen. When this occurs, the flower normally sheds unless pollen is brought to it from another flower by pollinators (McGregor, 1976).

#### ***1.2.4 Floral biology***

The cotton flower is borne singly and the number of flowers is determined by numerous factors including the available plant nutrition, water supply, variety, density of the plant population (McGregor, 1976) and climatic conditions (Sawan *et al.*, 2002). Usually there are not more than three open flowers per plant per day in *G. hirsutum* (Free, 1993).

Flowers open in the morning shortly after sunrise (McGregor, 1976), then later anthers of *G. hirsutum* dehisce to produce abundant pollen, and the corollas start to expand at 06:30 until they are fully open at 08:00-10:00 (Waller *et al.*, 1981b; Wilson & Stapp, 1984). Opening and dehiscence of anthers are also influenced by atmospheric conditions such as low temperatures and high humidity. The flowers begin to wilt in mid-afternoon or towards sunset, and never reopen (Free, 1993). Janki *et al.* (1968) studied the floral biology of five varieties belonging to the three major species of cotton and found that they differed in their commencement and period of flowering.

#### ***1.2.5 Nectar and nectary glands***

Nectaries are plant glands that are specialised for the production of nectar, which is a solution of sugars in water with minor amounts of other substances such as amino acids, minerals, essential oils and organic acids (Barker & Barker, 1971). Like many plants, cotton produces nectar which is a flavourless, odourless and colourless solution (Vansell, 1944a) that attracts insects and is usually regarded primarily as a reward for pollinators

which visit the flower. The nectar may also serve as an alternative source of food for beneficial insects and other arthropod species in cotton crops (Mohan & Kairon, 1999).

The cotton plant is unusual in that the nectaries are not limited to the flowers. Cotton has four sets of nectaries, one of which is floral with the other three being extrafloral. All the nectaries outside the flower are usually referred to as extrafloral nectaries (Mound, 1962; Butler *et al.*, 1972; McGregor, 1976). The floral nectaries are located at the base of the petals of the flower, where there are five small openings through which an insect with a long proboscis can reach the nectar. With regard to the extrafloral nectaries, the circumbracteal nectaries (usually three) are located between the three flower bracts, the subbracteal nectaries (usually three) are located just below the bracts (one nectary below each bract), and a leaf nectary is found on the underside of almost every leaf on the midrib. Occasionally, there are two more leaf nectaries, one on each of the first two main branches of the midrib (McGregor, 1976).

Floral nectar secretion of upland cotton has been studied extensively along with the factors that affect it, such as the season and time of day (Butler *et al.*, 1972; Moffett *et al.*, 1976b; Waller *et al.*; 1981b), variety (Vansell, 1944a; Butler *et al.*, 1972; Waller *et al.*, 1981b) and soil characteristics (Parks, 1921). Cotton is regarded as a slow nectar producer with a constant secretion rate ranging from 0.5  $\mu\text{L}$  to 2.2  $\mu\text{L}$  / h (Cruden *et al.*, 1983) and a total volume of nectar secreted on the day of opening between 5-33  $\mu\text{L}$  / flower, with the quantity varying greatly between varieties (Vansell, 1944a; Butler *et al.*, 1972; Moffett *et al.*, 1976b; Waller *et al.*, 1981b; Loper & Davis, 1985).

Quality of cotton floral nectar also varies greatly with variety, with sugar concentration (TDS) levels between 18-68% (Vansell, 1944a; Butler *et al.*, 1972; Moffett *et al.*, 1976b; Waller & Moffett, 1981; Waller *et al.*, 1981b; El-Banby *et al.*, 1985). Free (1993) reported that the different concentrations of floral nectar from different varieties may be explained partly by differences in the amount of evaporation occurring in the flowers. Vansell (1944a) found that the primary sugars in *G. hirsutum* nectar were glucose, fructose and sucrose, with glucose and fructose being predominant. Butler *et al.* (1972),

Moffett *et al.* (1975b) and Waller *et al.* (1981b) subsequently confirmed the high glucose content of both floral and extrafloral nectars.

Extrafloral nectary production was investigated by Butler *et al.* (1972), who reported that the quantity and quality of extrafloral nectars of *G. hirsutum* varied, for example, leaf nectar produced 1.85  $\mu\text{L}$  (TDS 49.1%) / plant / d while subbracteal glands produced only 0.6  $\mu\text{L}$  (TDS 15.3%); however, no circumbracteal nectar was recorded. The proportion of sugars was similar to floral nectar. There was a sharp decline in the availability of leaf nectar between 08:00-11:00. Moffett *et al.* (1976b) showed that floral nectar increased steadily from 08:00 to 17:00. Thus, leaf nectar appeared to diminish in availability as floral nectar increased.

### **1.3 COTTON POLLINATION**

#### **1.3.1 Pollination ecology**

Pollination is a key ecological process in sustainable agricultural production (Hoopingarner & Waller, 1992) and refers to the transfer of pollen on the stigma, either by close proximity of the anther (self-pollination) or by biotic or abiotic agents (cross-pollination). Cross-pollination provides greater variability in the offspring than does self-pollination. Cotton is commonly regarded as a partially cross-pollinated crop (McGregor, 1976; Tanda & Goyal, 1979a) but is largely self-fertile and self-pollinating (Free, 1993; Delaplane & Mayer, 2000).

Flowers of *Gossypium* spp. open in the morning shortly after sunrise (McGregor, 1976). The anthers of *G. hirsutum* dehisce after the flowers open and produce an abundance of viable, self-fertile pollen from 06:30-10:00 (Waller *et al.*, 1981b; Wilson & Stapp, 1984). Individual upland cotton flowers produce an average of 40,000-45,000 pollen grains (Barrow, 1981; Loper, 1986; Vaissiere, 1991b). Cotton pollen grains of freshly dehisced anthers appear as creamy powder. The individual grains are spiny, spherical, relatively large (i.e. 101.5  $\mu\text{m}$  and 122.5  $\mu\text{m}$  with/out spines, respectively) (Janki *et al.*, 1968), and covered with a viscous material (McGregor, 1976). These pollen grains are not readily carried to other flowers by wind (Tanda & Goyal, 1979c).

The effective initiation of the pollen-pistil interaction depends on the viability of the pollen and the receptivity of the stigma (Shivanna *et al.*, 1997). Pollen viability refers to the ability of pollen to deliver functional male gametes to the embryo sac (Shivanna *et al.*, 1991). Stigma receptivity refers to the ability of the stigma to support pollen germination and tube growth upon receiving compatible viable pollen (Shivanna *et al.*, 1997). In general, the stigma becomes receptive by the time the flower opens and the pollen is shed. However, this does not always occur and depends on the pollination mechanism (i.e. self or cross pollination) of a particular species (Sedgley, 1982).

The receptivity period is a critical time that influences fruit set in many crops that need honeybees for pollination. Crops with short receptivity periods may suffer pollination problems, particularly under unfavourable conditions for honeybee flights. In cotton, the maximum secretion of shiny sugary liquid in the stigma was observed from 04:00 (i.e. six hours before the flower opened) to 11:00; during this period the stigma was considered to be fully receptive (Janki *et al.*, 1968). Pollen grains are shed from the anthers at the two-celled stage so that the immature male gametophyte consists of a tube cell and a generative cell. Following adhesion of pollen grains to the stigma, the pollen germinates and a pollen tube rapidly penetrates the stigma and grows the length of the style into the ovary. The generative nucleus divides shortly after pollen tube emergence to form two sperm cells (Smith & Cothren, 1999). The maximum stigma receptivity is between 11:00 to 16:00 on the day of opening, but the receptivity drops sharply during the afternoon (Janki *et al.*, 1968). Thus, most pollination in cotton occurs by mid-afternoon.

In cotton, pollen grains germinate in about 30 min after deposition on the stigmatic hairs (Beasley, 1975) and remain viable for about 12 h (Free, 1993). The viability of the pollen decreases gradually from about 09:00. Barrow (1981) reported pollen germination exceeded 98% up to 8 h after anthesis, and Kearney (1923) found it was still able to fertilize 86% of the flowers to which it was applied at 17:00 on the day of anthesis. However, after 24 h, viability had dropped to 30% (Barrow, 1981) or as low as 11.7-18.5% (Janki *et al.*, 1968). Viability is temperature sensitive, with full viability occurring in the range 32 - 40°C, but with no germination above 42°C (Barrow, 1981).

Hand-pollination trials have provided some preliminary data about the required number of pollen grains necessary for full seed production in cotton. No seed matured following pollination with two pollen grains (Ter-Avanesian, 1978a), and five pollen grains per flower resulted in an abscission rate of 80-90% of flowers, compared to fully pollinated flowers. Previously, Meade (1918) reported that bolls failed to set unless at least 25 pollen grains were deposited on the stigma; even with this number only one or two seeds matured in each locule, suggesting that at least 25-55 pollen grains are required to reach the stigma in order to fertilize all the ovules in a boll. Ter-Avanesian (1978b) found bolls resulting from pollinations made with 20, 100 and 300 pollen grains were heavier and larger in size relative to naturally pollinated control flowers, but with 1000 grains there was no significant difference in the average weight of bolls. Vaissiere *et al.* (1982) also reported that bolls that matured from a stigma with  $\geq 50$  pollen grains produced significantly more (25.6) seeds than bolls produced from stigmas with  $< 50$  pollen grains (8.0). Waller & Mamood (1991) reported that a stigma needed about 100 viable pollen grains to set a full boll (i.e. 25-35 seeds / boll).

Fertilisation occurs, for most ovules, by the end of the first day post-anthesis (i.e. 12-24 hours after pollination) (Beasley, 1975) and temperature is the primary determining factor (Smith & Cothren, 1999). The post-pollination change in the colour of petals, from white to pink after fertilisation, begins at the petal tips. This progresses to encompass the entire corolla which becomes light red by sunset (Janki *et al.*, 1968; McGregor, 1976; Delaplane & Mayer, 2000). The deep red corolla and staminal column wither on the second day and fall off later (Delaplane & Mayer, 2000).

Red is out of the visual range of most insects, including bees (Kevan & Baker, 1983). The flowers of some insect-pollinated plants change similarly from white to red and this is often related to the termination of nectar secretion (Gori, 1983). In cotton, the corolla closes up when it turns to red so that floral nectar is not accessible anymore (Moffett *et al.*, 1981; Waller *et al.*, 1981b). Eisikowitch & Loper (1984) observed honeybee foragers ignoring such flowers, indicating that the bees associate change in colour and petal

condition with lack of reward. They suggested that a change in cotton flower colour by itself may not affect bee visitation, unless there is an absence of reward.

After fertilisation, the bolls and their developing seeds expand rapidly. Inside the seed, the embryo seedling is fully formed within five weeks after fertilisation. The oil and proteins that will provide the energy for germination accumulate mostly during the latter part of seed development (Smith & Cothren, 1999). While the embryo takes shape inside the seed, cotton fibres develop from the outermost layer of cells on the seed coat. Fibre initials (epidermal cells in the ovule) begin their elongation phase on the morning of anthesis (Beasley, 1975), and elongation ceases by about 24-28 d post-anthesis, and fibres are mature 50-70 d after anthesis. At maturity, the lint dries and the fibres become twisted in a way that makes them especially suitable for spinning. As bolls dry, they split and flare open, exposing lint and seeds. Before ginning, the lint and seeds are called seedcotton (Flint, 1996).

The main commercial product from cotton is the lint, which comprises approximately 40% of boll weight (Stephanie *et al.*, 2003). Both lint yield and quality are important in determining the economics of cotton production. Cotton classification, by High Volume Instrumentation (HVI), is used to determine the quality of the cotton fibre in terms of its physical properties, such as length, strength, uniformity, and micronaire (Anon, 2005a; see also Table 1.2).

- (1) Fibre length is the average length of the longer one-half of the fibres (upper half mean length), which range from 0.79-1.36 inch in upland cotton (Anon, 2008d). It is measured by passing a "beard" of parallel fibres through a sensing point. The beard is formed when fibres from a sample of cotton are grasped by a clamp, then combed and brushed to straighten and parallel the fibres.
- (2) Length uniformity is the ratio between the mean length and the upper half mean length of the fibres and is expressed as a percentage. Typical comparisons are illustrated in Table 1.2. Low uniformity index shows that there might be a high content of short fibres, which lowers the quality of the future textile product.

- (3) Fibre strength is measured in grams per tex. A tex unit is equal to the weight in grams of 1,000 m of fibre. It is determined as the force necessary to break the beard of fibres one tex unit in size, clamped in two sets of jaws, (1/8 inch apart). The breaking strength of cotton is about 3.0-4.9 g / tex.
- (4) Micronaire measurement reflects fibre fineness and maturity. A constant mass (2.34 g) of cotton fibres is compressed into space of known volume and air permeability measurements of this compressed sample are taken. These, when converted to the appropriate number, denote the micronaire value.

**Table 1.2 Measurements of cotton lint parameters used to determine the grade of cotton quality [Source: U.S. Department of Agriculture (2008d)]**

Length uniformity		Fibre strength		Micronaire	
Length uniformity	Uniformity index [%]	Degree of strength	Fibre strength [g / tex]	Cotton range	Micronaire reading
Very high	> 85	Very strong	> 31	Premium	3.7-4.2
High	83-85	Strong	29-30	Base	4.3-4.9
Intermediate	80-82	Average	26-28	Discount	> 5.0
Low	77-79	Intermediate	24-25		
Very low	< 77	Weak	< 23		

### ***1.3.2 Pollinating agents***

Cotton is commonly regarded as a partially cross-pollinated crop (McGregor, 1976). Since pollen grains of cotton are too heavy to be air-borne, wind does not play any role in cross-pollination (Tanda & Goyal, 1979c; Umbeck *et al.*, 1991), so insects are the likely natural agents for any pollen transfer. Most of the research on cotton pollination by insects has not been conducted in recent years, presumably because of high pesticide use. Most of the following references reflect this.

Flowers of *Gossypium* spp. produce nectar and pollen which attract many beneficial as well as harmful insects (Butler *et al.*, 1972), so numerous studies have been conducted to



identify insect visitors to cotton flowers. The European honeybee, *Apis mellifera* L. (Hymenoptera: Apidae), is considered the most important pollinator of cotton in the United States of America (USA) (Kearney, 1923; McGregor, 1959; Weaver, 1978; Moffett *et al.*, 1976a; 1976c, 1980; Vaissiere *et al.*, 1984; Waller *et al.*, 1985b; Loper & Danka, 1991; Free, 1993), in Egypt (Wafa & Ibrahim, 1959), India (Sidhu & Singh, 1962; Tanda & Goyal, 1979b; Tanda, 1983), and Sudan (El-Sarrag *et al.*, 1993). However, other species of honeybees including *Apis cerana* L. and *A. florea* L. (Sidhu & Singh, 1961; Tanda & Goyal, 1979a), and *A. dorsata* L. (Tanda, 1983) have also been reported to pollinate cotton.

In USA, native non-*Apis* hymenopteran species such as *Bombus* spp. (Apidae) (Moffett *et al.*, 1980, 1981; Berger *et al.*, 1988), *Melissodes* spp. (Anthophoridae) and *Agapostemon anglicus* Cockerell (Halictidae) (Moffett *et al.*, 1980, 1981), *Xylocopa varipuncta* Patton (Anthophoridae) (Waller *et al.*, 1985b), *Osmia fulviventris* (Panzer) (Megachilidae) (Waller *et al.*, 1978), *Megachile rotundata* (F.) (Megachilidae), *Halictus ligatus* Say (Halictidae) and *Anthophora confusa* Smith (Anthophoridae) (Moffett *et al.*, 1980; Loper & Danka, 1991), and stingless bee, *Trigona nigerima* (Apidae) (Loper & Danka, 1991), can be important visitors and pollinators of cotton flowers under some circumstances. The value of each species in pollination depends on their numbers, their visitation pattern and the time spent in each flower.

Although other insects may be efficient pollinators, *A. mellifera* is regarded as the most important pollinator of cotton worldwide because of its abundance and amenity to human handling (Moffett *et al.*, 1978a; Waller *et al.*, 1985a; Tanda & Goyal, 1979b; Free, 1993). Moffett *et al.* (1980) surveyed 13 cotton fields over a wide area of the Texas plains and concluded that wild bees and wasps were not dependable as pollinators because their populations fluctuated widely from year to year and between fields. Moffett *et al.* (1976d) found that high populations of non-*Apis* spp. (wild bees) were observed only in cotton fields near large acreages of native pasture and that due to modern agricultural practices, populations of wild bees were usually too low and unpredictable to reliably pollinate large acreages for hybrid cotton seed production. They concluded that rental of honeybee

colonies appeared to be the best means to ensure adequate bee populations for cotton pollination (Sidhu & Singh, 1961; Tanda & Goyal, 1979b; Moffett *et al.*, 1980, Vaissiere *et al.*, 1984).

### ***1.3.3 The role of honeybees as pollinating agents in cotton***

Cross-pollination by honeybees in commercial production of cotton involves a substantial cost for growers. Since beehives can be moved readily wherever honeybees are needed for pollination, beekeepers in USA have provided colonies to pollinate over 120 commercial crops, including cotton (McGregor, 1976). Although introduction of honeybees for cotton pollination is regarded as a supplementary management practice, bee pollination has consistently been reported to increase boll set, boll weight, seed per boll, seed weight, lint per boll, total cotton yield, and uniformity of boll ripening (Kuliev, 1958; McGregor *et al.*, 1955; Moffett *et al.*, 1978b; Vaissiere *et al.*, 1984; Waller *et al.*, 1985b; Rhodes, 2002). It also promotes earliness of seed set and decreases boll shedding (McGregor *et al.*, 1955), improves seed germination (Radoev & Bozhirov, 1961; El-Sarrag *et al.*, 1993), increases seed oil content (El-Sarrag *et al.*, 1993), and improves lint quality (McGregor *et al.*, 1955; Avetisyan, 1958; Kuliev, 1958; Kaziev, 1960; Tanda & Goyal, 1979a; El-Sarrag *et al.*, 1993; Rhodes, 2002). Numerous authors have cited increased yield (total boll weight) with reports of increases of 15-20% (Wafa & Ibrahim, 1960b; Sidhu & Singh, 1962; Stith, 1970; Tanda & Goyal, 1979b; Rhodes, 2002), 20-25% (Mahadevan & Chandy, 1959; McGregor & Todd, 1956; McGregor *et al.*, 1955; Radoev & Bozhirov, 1961; Tanda & Goyal, 1979a), 25-30% (Avetisyan, 1958; Kuliev, 1958; Kaziev, 1960), and more than 30% (Shishikin, 1952; Mahadevan & Chandy, 1959; El-Sarrag *et al.*, 1993).

The efficacy of honeybee pollination has been evaluated by different techniques, such as comparing fields with and without managed honeybees (Shishikin, 1946; Vaissiere *et al.*, 1984; Vaissiere, 1991a), yield in relation to the level of bee visitation (Rhodes, 2002), and bagging individual flowers and comparing to unbagged ones (Radoev & Bozhirov, 1961). However, the most common method has been by using cages, either to exclude bees from flowers or to cage them with flowers (Shishikin, 1952; Avetisyan, 1958;

McGregor & Todd, 1956; Mahadevan & Chandy, 1959; Sidhu & Singh, 1962; Moffett & Stith, 1972a; Waller *et al.*, 1985b; Tanda & Goyal, 1979a; El-Sarrag *et al.*, 1993; Rhodes, 2002). For example, McGregor *et al.* (1955) assessed the influence of bee activity on boll set, number of seeds and yield, by confining honeybees with Pima and upland cotton plants under plastic screen cages and comparing with caged plants without bees. While they recorded 24.5% higher yield of cotton seed from Pima cotton caged with bees, there was no yield increase in upland cotton, although there was earlier fruit set.

Honeybee visits to cotton flowers not only increase the amount of pollen deposited on the stigmas of the same plant, but may also increase the amount of foreign pollen introduced from other plants (of the same species) to the stigma. For instance, Kearney (1923) reported that stigmas of bagged cotton flowers were not always completely covered with pollen, but this was rarely the case with open flowers when insect visitation, particularly by honeybees, was high. Increased yield as a result of cross pollination may be related to such factors as increased numbers of pollen grains over the entire surface of the stigma (within a flower, pollen-laden anthers contact only the base of the stigma), and increased rate of pollen tube formation in pollen grains from other flowers (Kearney, 1923). These factors may result in higher fertilization of ovules, causing higher levels of boll setting and seed production. Thus, the measurable benefits from bee activity probably derive from bees increasing the amount and distribution of pollen on stigmas. This was further confirmed by Vaissiere *et al.* (1984) who reported that in the absence of bees, the number of pollen grains on stigmas was very low (0-7). In the presence of managed honeybees, this figure was often much higher. However, it was highly variable; for example, a range of between 1-324 pollen grains / stigma was recorded from a high visitation rate of 3.19 bees /100 flowers. Since Vaissiere *et al.* (1984) collected their samples 24 h after pollination; they suggested that factors other than bee visitation, such as flower or plant biology or the microclimate around flowers, were important in determining the number of pollen grains transferred onto stigmas within any one day.

The percentage of cotton flowers that develop into mature bolls is generally low. Even under the most favourable conditions many buds do not reach the blooming stage and

many flowers that open fail to set bolls. According to Smith & Cothren (1999), a cotton plant will normally shed about 60% of its squares and young bolls under typical crop growing conditions. However, McGregor (1976) showed that honeybee pollination increased boll set in cotton crops and this finding was subsequently supported by Moffett *et al.* (1978b), who reported that cotton plants placed in cages with bees set 23% more bolls per flower than plants not caged with bees. In addition, they found that the bolls harvested from bee-pollinated flowers were heavier and contained more seeds per boll than bolls that were bagged or caged to exclude bees. Vaissiere *et al.* (1984) stated that honeybee pollination affected the seed yield of the male-sterile parent primarily by its effect on boll weight and boll set. They suggested that the number of bolls per plant reflected the level of pollinator visitation throughout the season, while boll weight reflected the pollen transfer efficiency of those visits.

McGregor *et al.* (1955) found that cross-pollination between different cotton varieties gave a better yield than cross pollination within a variety. Several studies have also shown that honeybees can improve the quantity and quality of cotton through inter-varietal pollination of *Gossypium* spp. (Avetisyan, 1958; Kuliev, 1958; Free, 1993; McGregor, 1976), *G. arboretum* (Tanda, 1983; 1984), and *G. herbaceum* (Tanda & Goyal, 1979a; 1979b).

Honeybees have historically been most commonly used in cotton to produce hybrid varieties. Hybrid cottonseed is reported to only be produced when adequate numbers of bees are present to transfer pollen from the normal, male-fertile (MF) pollen parent to the male-sterile (MS) seed parent (Waller, 1982; Moffett & Stith, 1972a; Vaissiere *et al.*, 1984).

There has been only one report on efficacy of honeybees in cotton in Australia. Rhodes (2002) found, in the conventional cotton variety Siokra V-16, that plots with high bee visitation rates produced more harvestable bolls, and that they were heavier and contained more seeds and lint than those with low or no bee visitation. He also reported the harvested lint from these bolls had improved micronaire.

## ***1.4 MANAGEMENT OF HONEYBEE COLONIES DURING THE POLLINATION SEASON***

Using honeybees to pollinate a crop requires a sufficient number of high quality colonies and ensuring that these colonies can maintain good foraging activity throughout the flowering of the target crop. After moving bee colonies to a site, there are some other important techniques that are likely to assist in maintaining colony quality, such as providing the colonies with shade and easy access to water in hot and arid areas and managing the crop pests without harming bees (Martin & McGregor, 1973; Moffett *et al.*, 1974, 1977b; Johansen, 1977; Goebel, 1984; Jay, 1986).

There are three important considerations when colonies are imported, to insure they adequately pollinate the target crop:

### ***1.4.1 The stocking rate***

The stocking rate is defined as the number of imported colonies per unit area of target crop to pollinate. However, stocking rate is the major component of the cost of pollination and the economics of using honeybees for pollination is a key consideration in assessing profitability of the target crop production.

There is currently no recommended stocking rate of honeybee colonies to pollinate cotton, but some recommendations have been made in terms of the bee visitation rate (i.e. the number of bees in 100 flowers). McGregor (1959), using 200 colonies in 16 and 32 ha fields, concluded that ten or more honeybees per 100 flowers were indicative of a good boll set in Arizona. He suggested that the bee: flower ratio should be used as an indicator of the number of colonies required in a cotton crop for effective pollination. This technique excludes any bee working in extrafloral nectaries, which is unlikely to contribute to pollination of the crop. Since cotton is unattractive to honeybees, McGregor (1959) suggested that the number of colonies needed to maintain the desired rate of flower visitation may vary, according to the number of hectares of cotton and also densities of the other flowering plants in the vicinity which may be competing for the bees' attention. Thus, ten colonies per hectare may not be enough for a small field

surrounded by competing flowering plants whereas one colony may be sufficient for a more isolated field of several hectares.

In 1974, Moffett again reported that between one and ten honeybees per 100 cotton flowers could provide adequate pollination. Later Moffett *et al.* (1976d) suggested that 0.5% was adequate to obtain sufficient boll set in Arizona and Waller *et al.* (1985a) came to a similar conclusion.

**Table 1.3 Published stocking rates of honeybee colonies in cotton fields, and their associated visitation rates to cotton flowers.**

<b>Stocking rate* (Total number of colonies)</b>	<b>Area of cotton field (ha)</b>	<b>Mean bee visitation rate** (range)</b>	<b>Author/s (year)</b>
17.7 (400)	22.6	3.6	Moffett <i>et al.</i> (1978a)
6.2 (1000)	160	2.3	Moffett <i>et al.</i> (1978b)
14.8 (800)	54	-	Moffett <i>et al.</i> (1981)
7	-	0.44	Waller & Moffett (1981)
15	-	0.75	
7.5- 15.5	-	-	Vaissiere <i>et al.</i> (1984)
12.2 (649)	53	0.77 (0.4-1.7)	Waller <i>et al.</i> (1985a)
1.3 (200)	160	2.3	Moffett <i>et al.</i> (1985b)
0-35.5	-	0.5 (0-4.21)	Vaissiere (1991a)

\* Number of colonies per hectare.

\*\* Number of bees per 100 flowers.

As discussed above, the stocking rate required to achieve acceptable bee visitation rates in cotton varies, depending on numerous factors. Vaissiere *et al.* (1984, 1991a), using a wide range of stocking rates from 0 to 35.5 colonies / ha, concluded that cotton yield was correlated to the number of honeybee colonies provided. Moffett *et al.* (1981), Waller *et al.* (1985a), and Loper & Danka (1991) reported that while cotton yield decreased with increasing distance from the bee colonies, this was less than the reduction in bee visitation rate. A number of other researchers have investigated honeybee stocking rates in cotton and, often, the associated bee visitation rates, mostly in hybrid cotton

production. These are summarised in Table 1.3, and they demonstrate that there is no consistent relationship between these two parameters.

While there is some consensus of an optimum bee visitation rate of 0.5 bees / 100 flowers to maximise pollination in cotton, the practical calculation of the required stocking rate to achieve this is clearly difficult, both for farmers and beekeepers. This important issue will be discussed further in Chapter 7.

#### ***1.4.2 Scheduling the arrival and removal of honeybee colonies, in relation to flowering of the target crop***

The time when colonies are moved to a target crop relative to its stage of blooming influences the number of the foragers that are recruited and retained. It is suggested that colonies should be introduced at the onset of flowering of the target crop so that they do not become conditioned to the other competing floral sources (Ribbands, 1951; Free & Williams, 1974). The general recommendation is for beekeepers to bring their colonies when the target crop is at 10-20% flowering (Free *et al.*, 1960; Hoopingarner & Waller, 1992). However, timing appears to be crop-dependent, because, in some cases, early introduction of colonies may result in bees foraging out of the target crop, while a later time means that a high portion of the crop may not be cross pollinated (Free *et al.*, 1960; Moeller, 1972).

In cotton, there is no recommended time for importing hives, nor a recommended optimal pollination period to economically increase production. However, yield data might be the best indicator of the proper time for colonies to be introduced rather than bee counts and pollen trap analyses which are used in most studies of other crops, because these methods only provide indirect measures of pollination efficiency (Moeller, 1972). In addition, bee visitation to cotton flowers is extremely variable and depends upon location, time of day and date (Moffett *et al.*, 1980). For example, Moffett *et al.* (1976a) suggested that the most important period for bee visits in upland cotton, in Pima County U.S.A, were those that occurred in July to the middle of August; since most bolls set by the middle of August to the first week of September are damaged by frost and do not mature. On the

other hand, Phillips & Simpson (1989) stated that with proper honeybee management and pollination timing, the quality of hybrid seed produced would be improved by using bees only for the first half of the flowering period. Irrespective of the optimal period of bee pollination, it appears that bee visitation is not able to be controlled since Moffett *et al.* (1980) reported that even when there are large populations of bees in cotton fields, they may sometimes completely ignore the flowers and continue collecting extrafloral nectar. Therefore, even a level of 0.5 bees / 100 flowers may sometimes be difficult to achieve reliably.

#### ***1.4.3 The spatial distribution of the colonies in relation to the target crop area***

Placement of honeybee colonies in or near the crop can be an important aspect of efficient pollination, although requirements vary for different crops (Liven, 1961). Todd & McGregor (1960), for example, reported that placing a single apiary on the edge of the field or orchard is an inefficient use of pollinators, and they suggested locating colonies in the centre of fields. Although this might be possible in orchards such as almonds, it is impractical in many field crops such as cotton, because it may interfere with the other necessary agricultural practices. Previous studies in many crops have shown that the most effective pollination occurs when honeybee colonies are scattered singly (Oldershaw, 1970), in small groups (i.e. four to five colonies) throughout the target crop (Free *et al.*, 1963), or at least along most sides of the field (Moffett *et al.*, 1974).

In cotton, Vaissiere *et al.* (1984), Moffett *et al.* (1981), and Waller *et al.* (1985a) confirmed that pollination efficiency of honeybees was dependent not only on the number of colonies but also on their distribution in the field. Bees usually visit flowers close to their hives when they are available (Ribbands, 1953; Free & Williams, 1974; Free, 1993) and, consistent with this, Waller *et al.* (1985a), Loper & Danka (1991) and Vaissiere *et al.* (1984) have reported reduced bee foraging activity with increased distance of flowering cotton plants from honeybee colonies. Thus, locating colonies in small batches close to a large cotton crop appears to be important to achieve higher and uniform bee flower visitation.



### **1.5 HONEYBEE FORAGING BEHAVIOUR IN COTTON FLOWERS**

Honeybee foraging behaviour is one of the important research areas in pollination biology. Honeybees change their foraging behaviour in response to the needs of the colony and the availability of food sources in the field (Seeley, 1985). Subsequently, the foraging of individual bees varies with the size of the foraging population and the overall competition for nectar and pollen resources. In cotton plants, most foraging honeybees have been routinely observed collecting nectar (from both infloral and extrafloral nectary glands) rather than pollen.

Several authors have recorded diurnal foraging patterns of honeybee in cotton (Wafa & Ibrahim, 1959; Moffett *et al.*, 1980; Moffett *et al.*, 1981; Waller *et al.*, 1985a; El-Sarrag *et al.*, 1993). They concluded that extrafloral nectaries were preferred by bees in the early morning, and suggested that the foragers divide their time by collecting extrafloral nectar throughout the morning and floral nectar during the afternoon. Honeybee numbers were lowest in late afternoon. Tanda & Goyal (1979c) found that insect visitation commenced as soon as *G. arboreum* flowers opened (08:00) with maximum activity at 10:00 - 11:00 and little foraging after 13:00, although this is somewhat inconsistent with Moffett *et al.*'s (1980) report that bee visits to *G. hirsutum* flowers were highest between 10:00 - 16:00 and peaked at 13:00 - 14:00.

Honeybees are attracted to cotton flowers because of their nectar, not pollen. Therefore, the quantity and quality of nectar and the pattern of its availability in different cotton genotypes assists in understanding bee foraging activity and pollination biology. Honeybee foraging behaviour in cotton varies, depending on the availability and relative abundance of extrafloral and floral nectaries, and the time of day (Eisikowitch & Loper, 1984). Moffett *et al.* (1975b) reported that cotton genotypes with floral nectar containing higher sugar concentrations usually attract more honeybees to their flowers, and Waller (1972) found that honeybees preferentially visited artificial flowers with high sugar (sucrose) concentration, with the optimum total sugar content being between 30-50%. Since the sugar concentration of floral nectar in most commercial cotton plants is lower

than this optimum (see Section 1.2.5), Moffett *et al.* (1978a) have suggested that high sugar concentration of nectar be considered in selecting parental lines for hybrid cotton.

Apart from the frequency of flower visits, another important aspect of honeybee foraging behaviour which influences pollination efficacy is the length of time they spend on individual flowers (handling time). There are several reports on handling time and other inflorescence behaviour of honeybees (*A. mellifera* and *A. cerana*) in cotton (Sidhu & Singh, 1961; Moffett *et al.*, 1975a; Tanda & Goyal, 1979b; Tanda, 1983; Buchmann & Shipman, 1990; Loper & Danka, 1991), with mean handling times reported from between 3.9 - 12.8 sec / flower.

Reports on the seasonality and patterns of bee visitation to cotton flowers are somewhat conflicting. Moffett *et al.* (1975a, 1976b, 1978b, 1980) reported that honeybee visits to cotton flowers vary greatly within and between flowering seasons, locations and varieties. Numerous studies have shown that a relatively low percentage of honeybee visits to cotton flowers occur during midseason but higher percentages may occur at the beginning and the end of the flowering season (McGregor, 1976; Moffett *et al.*, 1979a). Moffett *et al.* (1975b) further found that none of the 81 cotton genotypes they studied were sufficiently attractive to honeybees to overcome the mid-season drop in bee visitations that occur in southern Arizona. Weaver (1978) reported that total bee activity dropped sharply during the later portion of flowering in isolated fields of cotton, even though they had received no insecticides. Moffett *et al.* (1980), in one investigation, recorded higher bee visits to cotton flowers in the first two weeks than in the following weeks, although previous investigations (Moffett *et al.*, 1975a, 1979a) had indicated there was an increase in bee visits in late flowering. These observations may simply be a consequence of lower flower numbers at the commencement and conclusion of the season.

Although nectar-gathering honeybees often emerge from a cotton flower liberally dusted with pollen, they generally visit several flowers in quick sequence until they collect a full nectar load. Then, before returning to the hive, they spend between 15 min (Loper, 1986) and 20-30 min (Loper & DeGrandi-Hoffman, 1994) to scrape the pollen grains from their

body with their legs: this implies that the bees actively reject cotton pollen. This issue is discussed in more detail in Section 1.5.2.

### ***1.5.1 Pollen gathering activity***

Pollen is the male germplasm of the plant. It is practically the sole source of proteins, fatty substances, minerals, and vitamins that are necessary for rearing of larvae and the development of newly emerged bees (Haydak, 1970). A shortage of pollen and/or the availability of poor quality pollens which do not contain the necessary nutrients limit the growth of bee colonies (Loper & Berdel, 1980). Cotton flowers produce very high amounts of pollen of an acceptable nutrient value. Chemical analysis of cotton pollen was conducted by Stace (1994), who found a crude protein (CP) level of 19.4% which is just below the 20% CP required by honeybees (De Groot, 1953), and a good essential amino acid profile, with only iso-leucine a little below the level required by honeybees.

Although cotton plants offer both nectar and pollen to visiting insects, honeybees rarely collect its pollen grains (Vansell, 1944a; McGregor, 1959; Moffett *et al.*, 1975a; Loper & Davis, 1985; Waller *et al.*, 1985a; Vaissiere, 1991a). Tanda & Goyal (1979b) reported that only 12% of honeybees visiting *G. arboreum* gathered pollen. Loper & DeGrandi-Hoffman (1994) reported up to 23.4% of honeybee visitors collected pollen from *G. hirsutum*, but less (7.1%) collected from *G. barbadense*. This difference may be a result of relative flower attractiveness. Moffett & Stith (1972a) and Waller & Moffett (1981) reported that honeybee preference for some hybrid cotton lines was due to pollen avoidance since flowers of both lines produced similar quantities of nectar.

Other authors, however, have reported pollen collection by honeybee foragers, under certain situations. For example, Danka (2005) reported that approximately 80% of pollen gatherers entering hives located near cotton crops had collected cotton pollen. Furthermore, Eisikowitch & Loper (1984) found that honeybees caged with flowering cotton effectively collected cotton pollen, and concluded that there was no physical problem interfering with cotton pollen collection by honeybees. They suggested that honeybees may normally bypass cotton to forage on more attractive flowers, but in a no-

choice situation they will collect cotton pollen. Vaissiere (1991a) and Waller *et al.* (1981b) also agreed that honeybees will collect cotton pollen under stress conditions, with Vaissiere commenting that he observed only one field out of 23 where honeybee foragers were gathering pollen; and this was because these colonies were experiencing a severe dearth of pollen. Danka (2005) suggested that high humidity might also stimulate pollen collection. The factors discussed above might explain why Loper & Davis (1985) observed that honeybees only collected corbicular loads of cotton pollen during the first week after colonies were moved into the area.

Each cotton flower produces an average of 30,000 - 40,000 pollen grains, representing a weight of 19-26 mg of fresh pollen (Vaissiere, 1991b). However, the average size of a honeybee pollen load from honeybees observed foraging in *G. arboreum* was only 10.3 mg (Tanda, 1984), whereas the average size of a honeybee pollen load on most crops is 15 mg (Maurizio, 1953, cited in Keller *et al.*, 2005). Cotton pollen grains are large and echinate and they readily get caught in the hairs of apoids foraging for floral nectar (Vansell, 1944a; Berger *et al.*, 1988), and sometimes to the extent that the coated bee cannot fly away (Vaissiere, 1991a). Honeybees painstakingly groom cotton pollen from their body and this grooming behaviour has been interpreted as cotton pollen avoidance or rejection (Loper & Davis, 1985).

Several authors have commented on the relative “repellency” of cotton pollen (Tanda & Goyal, 1979b; Loper & Davis, 1985) and a number of studies have been conducted to explain the avoidance behaviour of honeybees to cotton pollen (Loper, 1986; Vaissiere & Vinson, 1994). Vansell (1944a) and Buchmann & Shipman (1990) suggested that the large size of cotton pollen grains and their covering with beads of viscous material was such that honeybees were unable to pack these into their corbiculae. Later, Moffett (1983) proposed that the presence of gossypol in cotton pollen may act as a toxicant or repellent. However, Loper (1986) stated that when pollen of *G. hirsutum* was chemically analysed for gossypol and 6-methoxygossypol content, very little (< 0.003%) or none of either chemical was found. He concluded that gossypol was unlikely to act as a toxicant or repellent to honeybees.

Other physical reasons for the relative “repellency” of cotton pollen have also been proposed. Vaissiere & Vinson (1994), investigating the efficacy of honeybee pollen collection using cotton and five other spheroidal pollen taxa, found that the rate of pollen collection was 0%, 16%, and 71% of landing foragers in okra, cotton and pumpkin whereas pollens of corn, pigweed and sunflower were readily collected by nearly all foragers. They also reported that the reduced effectiveness with which honeybees collected cotton pollen was demonstrated by (i) the longer time needed for pollen grooming and packing between two consecutive landings in a pollen dish and (ii) the small size of cotton pollen pellets. They concluded that this reduced efficiency in cotton pollen collection was associated primarily with the long spines on cotton pollen which physically interfered with the pollen aggregation process that honeybees use to pack their pollen pellets.

Pollen traps have also been used to assess pollen preference by bee foragers (Olsen *et al.*, 1979; Dimou & Thrasyvoulou, 2007). A number of studies of hive-collected pollen during cotton flowering seasons have confirmed that cotton pollen is not honeybees’ first choice when other, more attractive, plants are blooming. Loper & Davis (1985) reported that colonies fitted with pollen traps dramatically increased their pollen collection when *Larrea divaricata* Cav. (Zygophyllaceae) commenced to bloom, apparently diverting bees from cotton. Waller *et al.* (1985a) reported that weekly amounts of pollen collected from eight colonies fitted with pollen traps and adjacent to hybrid cotton fields varied from 403 g to 1316 g / colony / week; however, only four cotton pollen pellets were found among more than 10,000 examined. In Australia, Rhodes (2002) also reported that no cotton pollen was detected in pellets collected by a pollen trap on a hive in an apiary located next to a flowering cotton crop. However, when Waller *et al.* (1981b) analysed pollen from traps of two bee colonies they recorded 18% and 44% cotton pollen in trapped pollen pellets, and Danka (2005) reported that approximately 26% of pollen pellets were from cotton. Thus, the conclusion from all of the field observations and pollen trapping investigations is that while honeybees may collect cotton pollen, they prefer pollen from other floral sources. It should be noted however, cotton pellets are small and may not be as likely to be collected in pollen traps of 30% efficacy.

### 1.5.2 Nectar gathering activity

The majority of honeybee foragers collect nectar of various plant species rather than pollen (McGregor, 1976). The density of foraging bees on cotton is primarily influenced by the nectar, which is secreted by both floral and extrafloral nectaries (Butler *et al.*, 1972) (see also Section 1.2.5), and honeybee foragers switch readily between the two types of nectaries, with their proportions depending on the cultivar (Moffett *et al.*, 1975b; Waller *et al.*, 1981b; Eisikowitch & Loper, 1984), and the time of day (Moffett *et al.*, 1976b; Waller *et al.*, 1981b). The variability in nectar concentration, discussed in 1.2.5, is likely to be related to the floral morphology and microclimate inside the flower. Cotton has cup-shaped flowers and the nectar accumulates at the base of the calyx, which fits snugly against the petals, reducing the passive concentration of the nectar by exposure to the air. Vaissiere (1991a) suggested it also made the floral nectar accessible only to bees which enter inside the corolla and probe between the petals. Wafa & Ibrahim (1959), reporting that honeybees may collect floral nectar whilst remaining outside cotton flowers, also described their normal floral visitation behaviour as:

“the honeybee enters the flower, passes round the anthers and pushes the proboscis in the space between the base of petals to suck nectar”.

Reports in the literature of the effect of floral and extrafloral nectaries on honeybee foraging behaviour are somewhat confusing. Gourt (1955), McGregor (1976), and Free (1993) reported that the honeybees prefer extrafloral nectaries. However, Moffett *et al.* (1975b) noted that the absence of extrafloral nectaries did not affect the attractiveness of cotton plants to honeybees. Again, Loper (1986) reported that there was no preference in honeybee visitations to flowers of glanded and glandless *G. hirsutum* and *G. barbadense*. Tanda & Goyal (1979b) found that 80% and Rhodes (2002) 70% of nectar gatherers collected from extrafloral nectaries. On the other hand, Eisikowitch & Loper (1984) reported that in hybrid cotton lines, 75 to 100% of nectar gathering bees collected floral nectar in *G. hirsutum*, but only 24% collected floral nectar in *G. barbadense*.

Waller & Moffett (1981) suggested that bees divide their time by collecting extrafloral nectar throughout the morning and floral nectar during the afternoon. However,

Eisikowitch & Loper (1984) reported that during the afternoon, when secretions from floral nectaries dwindle, bees switch again to extrafloral nectaries, although individual bees may switch between either nectar source even during the same flight. It appears that honeybee foragers have learned that cotton flowers usually do not open until two to three hours after sunrise and that the plants do not secrete any nectar until some time after flower opening (Vansell, 1944a). Tanda & Goyal (1979b) observed that the sugar concentration of cotton nectar gathered by honeybees from floral and extrafloral nectaries was inversely proportional to the relative humidity of the air. Indeed, honeybees prefer sugar solutions above 30% TDS (Waller, 1972). Moffett *et al.* (1976b) found that the attractiveness of cotton was influenced by the sugar concentration rather than the volume of the floral nectar, and thus bees may not visit cotton flowers even when nectar is abundant (Moffett *et al.*, 1980; Delaplane & Mayer, 2000). Nectar sugar composition and concentration has been previously discussed in Section 1.2.5.

The different nectaries of a cotton plant produce nectar which contains about 20% sugar concentration (Vansell, 1944a). Evaporation of water from the nectar is greater in the exposed extrafloral nectaries than the floral nectaries, causing a more rapid increase in sugar concentration in the extrafloral nectaries (Vansell, 1944a). Thus the sugar concentration in the extrafloral nectaries can reach a maximum of 60-82% compared to 20-54% in floral nectaries (Parks, 1921; Grout, 1955). Furthermore, while the floral nectaries secrete only on the day a flower is open, the extrafloral nectaries secrete for a number of days and any nectar that remains from a previous day has a longer time to become more concentrated. Consequently, honeybees do not visit the floral nectaries until the extrafloral ones are exhausted. Therefore, increasing bee populations by concentrating honeybee colonies in or near cotton fields may increase bee visitation to floral nectaries, by exhausting extrafloral nectaries earlier (Grout, 1955; McGregor, 1959).

### ***1.5.3 Cotton as a honey plant***

Nectar production by the cotton plant has historically been of economic importance to commercial beekeepers in a number of countries such as USA (Parks, 1921; Butler *et al.*, 1972; Martin & McGregor, 1973; Waller, 1982), USSR (Kuliev, 1958), and Egypt (Wafa

& Ibrahim, 1959; El-Banby *et al.*, 1985), although there are no recent references of its current status, particularly since the increased use of modern synthetic pesticides. However, this has not been the case in Australia (Rhodes, per. comm., 2006).

Reports of potential honey production from cotton, based on actual measurements of nectar production from flowers, vary between authors. One hectare of *G. barbadense* cotton has been estimated to produce 31 (Parks, 1921) and 44 (Waller *et al.*, 1981b), but as low as 15.1 (Butler *et al.*, 1972) kg honey / ha. Out of the 200 nectar producing plants listed by Crane (1975), cotton was in the lowest class, with 0-25 kg honey / ha. Daily honey yields have been estimated to be 0.12 - 0.76 kg / d / ha (Butler *et al.* 1972; Waller *et al.*, 1981b; El-Banby *et al.*, 1985). Honey yield of *G. hirsutum* was much less than *G. barbadense* (Butler *et al.*, 1972).

A similar variation occurs when actual honey collected by honeybee colonies (as measured by hive weight differences) is used as a measure of cotton-honey production. Average collection of honey per colony was reported to be 43 kg (Grout, 1955), 15-20 kg (Avetisyan, 1958), presumably over the cotton flowering period, although daily honey collection has been reported to be as low as 0.114 kg (Waller *et al.*, 1981a), 0.589 kg (McGregor- unpublished, cited in Butler *et al.*, 1972), to 0.8-2.5 kg (Kuliev, 1958). Waller *et al.* (1981b) confirmed Vansell's (1944b), McGregor & Todd's (1956), and Butler *et al.*'s (1972) view that *G. barbadense* was a better nectar producer than *G. hirsutum*, by reporting an estimated 44 kg and 28.6 kg honey yield per hectare from *G. barbadense* and *G. hirsutum*, respectively. McGregor & Todd (1956) reported *G. hirsutum* provided good honey crops only on some occasions at certain localities. This is consistent with the findings of Vaissiere (1991a) who reported a non-significant increase in mean hive weight of 3.4 kg in one *G. hirsutum* field, but a significant increase of 21.5 kg in another. The above data should be interpreted with caution, because the reported figures of cotton-honey collection are based on changes in hive weight, with no attempt to determine whether the nectar had come from cotton or from other nearby, non-cotton, plants.



#### 1.5.4 *Attractiveness of flowering cotton plants*

Bees are attracted to flowers that are available in large numbers, that have readily accessible pollen and/or nectar, and that are rewarding in terms of energy (Kevan & Baker, 1983). The quantity of nectar and the concentration and type of constitution sugars in floral nectars determine their attractiveness to bees; however, less is known about what attracts bees to particular pollens (Hopkins *et al.*, 1969).

Competition from abundant and more attractive non-cotton nectar and pollen sources within the flight range is probably responsible for the reported low honeybee visits to cotton flowers (Moffett *et al.*, 1975a; Butler *et al.*, 1972). Vansell (1944a) reported that nectar collection from cotton is influenced adversely by the presence of other plants with richer nectars, particularly alfalfa, *Medicago sativa* L. (Leguminosae), although it is clear that other crops, non-crop plants and weeds may also be more attractive to bees than cotton.

Several studies of hive-collected pollen during the cotton flowering season confirm that large amounts of pollen were collected from creosote-bush (Loper & Davis, 1985), pearl millet, *Pennisetum americanum* L. (Poaceae); ragweed, *Ambrosia* sp. (Asteraceae) (Waller *et al.*, 1985a), smartweed, *Polygonum pensylvanicum* L. (Polygonaceae) (Waller *et al.*, 1985a; Vaissiere, 1991a), sorghum, *Sorghum bicolor* (L.) Moench. (Poaceae) (Waller *et al.*, 1985a; Rhodes, 2002), sunflower, *Helianthus annuus* L. (Asteraceae) (Waller *et al.*, 1985a; El-Sarrag *et al.*, 1993), and pigweed, *Amaranthus palmeri* S. Wats (Amaranthaceae) (Vaissiere, 1991a), when these plants were in bloom, and they appeared to divert bees from the cotton fields. Grout (1955), Moffett *et al.* (1975a), and Waller (1982) reported that after mid-summer weeds appeared in cotton fields, more pollen became available and brood rearing in honeybee colonies increased. Flowering trees may also be highly attractive to bees. For example, tamarisk trees, *Tamarix aphylla* L. (Tamaricaceae) attracted large numbers of honeybees away from the cotton flowers; the competition from this source was probably one of the main reasons for the mid-season slump in bee visits to cotton flowers (Moffett *et al.*, 1972a; 1975a; 1979a).

## ***1.6 TECHNIQUES USED TO INCREASE ACTIVITY OF HONEYBEES, AND THEIR POLLINATION EFFICACY***

Honeybee pollen collection from the target crop is the most important concern for both growers and beekeepers. Previous researchers have reported some techniques used to encourage pollen gathering activity of honeybees during the pollination season of various crops. Honeybee colonies can be stimulated to collect pollen through genetic selection (Hellmich *et al.*, 1985; Danka, 2005), by manipulating the amounts of brood and pollen (Chambers, 1985; Fewell & Winston, 1992; Eckert *et al.*, 1994; Dreller *et al.*, 1999; Danka, 2005), by feeding pollen supplements (additional pollen) or substitutes (Purdie & Doull, 1964; Doull, 1980a,b; Goodwin *et al.*, 1994), by removal of pollen from the hive (Hirschfelder, 1951; Free, 1967; Camazine, 1990; Tsirakoglou *et al.*, 1997), by trapping pollen to prevent its entry into hives (Lindauer, 1953; Rashad & Parker, 1958; Liven & Loper, 1984; Chambers, 1985), by substituting honey for pollen stores (Free, 1967; Barker, 1971), by providing sugar syrup (Goodwin, 1986, 1997), and by using brood pheromone in the hive (Pankiw *et al.*, 1998, 2004), or applying bee attractants to flowering target crops (Burgett & Fisher, 1979; Mayer *et al.*, 1989; Currie *et al.*, 1992a,b; Naumann *et al.*, 1994; Ambrose *et al.*, 1995; Neira *et al.*, 1997).

### ***1.6.1 The use of pollen traps to increase bee activity***

The use of pollen traps by beekeepers has greatly increased over a number of years, with the increased use of pollen for bee feeding and for human consumption (Abreu, 1992; Block *et al.*, 1994; Bonvehi & Jorda, 1997; Diaz-Losada *et al.*, 1998; Kroyer & Hegedus, 2001). Many beekeepers have added pollen production as an income-producing supplement to honey production and crop pollination. Pollen traps may be used to determine the suitability of a permanent location for an apiary (Nabors, 1997; Dimou & Thrasyvoulou, 2006), or to monitor pollen availability near apiaries so that colonies can be provided with pollen substitutes or pollen supplements when required (Cook, 1985; Dimou & Thrasyvoulou, 2006). They may also be used to control varroa mite, *Varroa jacobsoni* Oudemans (Acari: Varroidae) (Hart & Nabors, 1999).

Pollen traps vary in size and design, although they have almost the same mode of action. The traps are normally placed under the hive, and they force bees to enter a series of screens that scrape the pollen off the hind legs of returning field bees, with the pollen pellets being caught in a collection tray underneath. Some trap designs are more efficient than others, depending on wire size, spacing between wires, or in some cases, the number of round holes in a perforated plate (Loper *et al.*, 1984). The optimal diameter for holes in the pollen scraping-insert is 4.77-4.79 mm (Bienkowska & Pohorecka, 1996). However, the percentage of the pollen loads that are trapped depends on the size of the loads, which can vary considerably (Synge, 1947), as well as by adverse weather conditions which cause bees to return to hives before full loads have been collected.

The density of honeybee flight activity and pollen collection have been correlated with the amount of brood rearing (Todd & Reed, 1970; Al-Tikrity *et al.*, 1972) and the amount of pollen stored (Barker, 1971; Eckert *et al.*, 1994) in the colony. Also, egg laying by the queen is correlated with the amount of pollen collected (Cale, 1986). According to Lindauer (1955), in colonies with large quantities of brood and a shortage of pollen, more of the foragers will gather pollen. Lindauer (1953) also found a larger percentage of pollen gatherers in colonies fitted with pollen traps. This suggests that pollen traps could be used to stimulate pollen collection by honeybee foragers.

Currently, scientists use pollen traps to collect information relating to colony food intake, brood rearing activity, bee foraging behaviour, pollination activity, field pollen flow, pollen preference by bees and population dynamics (Hirschfelder, 1951; Allen & Jeffree, 1956; McLellan, 1976; Goodwin & Perry, 1992; Nabors, 1997; Dimou & Thrasyvoulou, 2007). These studies have resulted in many publications in which pollen traps have been described.

The literature on pollen traps frequently reports their stimulating effect on pollen collection. Webster *et al.* (1985) reported that bee foraging activity (number of in-coming bees / min) was higher in trapped colonies. An increased number of foragers in hives with traps has also been reported by Rashad & Parker (1958) (that 53% efficient pollen traps

increased foraging activity by 80%), Hirschfelder (1951), Lindauer (1953), Rybakov (1961), Moriya (1966) and Chambers (1980). While Liven & Loper (1984) reported that traps did not affect the number of bees leaving a colony they noted a higher proportion of pollen gathering bees in colonies with traps. Thorp (1979) and Webster *et al.* (1985) found both a greater number of foraging bees in almond orchards from colonies with pollen traps and higher percentages of foragers carrying pollen. However, the amount of stored pollen in hives with traps can be adversely affected (Hirschfelder, 1951; McLellan, 1974; Goodman, 1974).

The literature is inconsistent about the effects of pollen traps on colony behaviour and development. Waller *et al.* (1981a) reported a decrease in brood rearing and bee population after AOC traps were used for two months. Similarly, Ibrahim & Selim (1974) reported a decrease in sealed brood area, averaging 39.5%, when using pollen traps for the greater part of the active season. This detrimental effect of trapping pollen on brood production and adult bee populations has also been reported by Eckert (1942), Rashad & Parker (1958), Loper *et al.* (1984), and Duff & Furgala (1986). However, a number of other investigators have reported little or no effect on brood rearing resulting from the presence of traps (Hirschfelder, 1951; Rybakov, 1961; Lavie & Fresnaye, 1963; Lavie, 1967; Goodman, 1974; McLellan, 1974; Cook, 1985). This may be because of the different periods of time the traps were used, as well as differences in trap efficiency (see above).

The installation of pollen traps may influence other bee activities and their behaviour. For example, honey production of colonies has been reported to be negatively affected in trapped colonies (Hirschfelder, 1951; Rashad & Parker, 1958; Moriya, 1966; Lavie, 1967; Duff & Furgala, 1986), with Rashad & Parker (1958), reporting 41% reduction and Hirschfelder (1951) reporting 20% reduction. On the other hand, Rybakov (1961) reported a 13% increase in honey production from trapped colonies. Honey moisture content has also been reported to be adversely affected by traps on colonies (Duff & Furgala, 1986). Long term use of pollen traps may additionally affect colonies by

increasing their tendency to swarm (Goodman, 1974) and reducing their overwintering ability (McLellan, 1974).

### ***1.6.2 Provision of supplementary food and its effect on bee activity***

Pollen is the sole source of protein, lipids, minerals and vitamins for honeybee colonies. Shortage of pollen results in decreased brood rearing, decreased lifespan in adult workers, and poor honey production (Haydak, 1945, 1970; Maurizio, 1950; Doull, 1980b). Since pollen is often not present in adequate quantities in the field, beekeepers commonly feed bees with pollen substitutes (commonly containing soybean flour, skim milk and sugar), supplements containing pollen with other materials, or commercially trapped pollen. These are used to stimulate brood rearing, build up colonies to exploit honey flows, to produce colonies suitable for pollination, as well as for queen rearing and package-bee production. Several commercial bee food mixtures have been developed, such as Sojapyl (Purdie & Doull, 1964), Krawaite (Forster, 1966), Bee Feast and Pollenex (Herbert & Shimanuki, 1980), Wheast<sup>TM</sup> (Chalmers, 1980), and Feed-Bee<sup>®</sup> and Bee-Pro<sup>®</sup> (Safari *et al.*, 2004).

Consumption rates of pollen supplements or substitutes are closely related to the amount of brood being reared in the hive (Palmer-Jones, 1947; Forster, 1966, 1968a, b; Standifer *et al.*, 1971, 1973; Herbert & Shimanuki, 1980; Waller *et al.*, 1981a), although Waller *et al.* (1981a) reported that provision of supplements did not significantly affect the brood pattern. Doull (1973b) presented a detailed analysis of the correlations between feeding of pollen supplements and brood rearing, pollen gathering and honey production. He reported that there were positive correlations between the rate of brood rearing and the consumption of pollen supplements by colonies. Increasing the amount of brood in the colony also leads to an increase in pollen collection (Filmer, 1932; Free, 1967; Todd & Reed, 1970; Al-Tikrity *et al.*, 1972; Hellmich & Rothenbuhler, 1986; Eckert *et al.*, 1994), and to a temporary increase in the amount of pollen stored in the hive (Hellmich & Rothenbuhler, 1986).

Many studies have examined the effect of providing colonies with pollen or a pollen substitute, on their subsequent field pollen collection and nectar collection activity (Seeley, 1985). Providing colonies with pollen or a substitute reduces the proportion of foragers collecting pollen (Free, 1967; Free & Williams, 1971), whereas removing pollen increases the proportion collecting pollen (Fewell & Winston, 1992; Camazine, 1993). However, its impact on pollination is less clear. This would depend on which foragers (pollen or nectar gatherers) were the most important pollinators in the specific crop in question. Sheesley & Poduska (1968) reported that supplementary feeding improved colony strength and pollination efficacy, whereas Goodwin *et al.* (1994) found that feeding pollen substitutes to honeybee colonies in kiwifruit, *Actinidia deliciosa* (A. Chev.) C. F. Liang A.R. Ferguson (Actinidiaceae), orchards had no significant effect on the amount of kiwifruit pollen collected by the bees. Feeding bees with pure pollen, as compared to pollen supplements or substitutes, further reduces their pollen collection (Free & Williams, 1971; Moeller, 1972).

Honey gathering activity may be affected positively by provision of supplementary food or pollen. Purdie & Doull (1964) reported an increase of 35.8 kg honey / colony after supplementary feeding during a blue gum, *Eucalyptus globulus* Labill (Myrtaceae), honey flow in South Australia and Doull (1980b) reported a 38% increase in honey production / colony. Also, Nabors (2000) reported an increase in honey production after spring feeding with a pollen substitute, while Shoreit & Hussein (1993) reported increase in honey production following provision of soybean flour. In contrast, Goodwin *et al.* (1994) found that pollen substitutes had no effect on honey production in colonies used for kiwifruit pollination, nor for colonies managed for honey production.

### ***1.6.3 Use of pollination enhancement chemicals on bee activity and pollination***

The importance of insect pollination in many crops, and the key role of honeybees as pollinators have been discussed previously by McGregor (1976), Free (1993), and Delaplane & Mayer (2000). However, some crops do not receive adequate pollination even when honeybees are abundant due to factors such as unattractive flowers, poor

weather during the pollination period and/or competition from more attractive plant species nearby (McGregor, 1976; Jay, 1986; Free, 1993).

A number of bee-attracting chemicals have therefore been used to increase bee visitation to flowers of the target crop, with a view to increasing its pollination. The first reported use of a bee attractant was high concentration sugar syrups. However, Free (1965) reported that spraying apple trees with the syrups to increase bee visits in an apple orchard was counter-productive because bee activity was diverted to collecting sugar that had deposited on the leaves and petals of the apple tree rather than seeking nectar in the flowers. Free (1968c) therefore concluded that the major obstacle in pollination management of bees was the problem of attracting bees away from more attractive competing flowers or nectar sources. To overcome the failure of sugar product sprays to attract bees to flowers of target crops, an alternative strategy in pollination management of bees was to use sprays that relied on olfactory attractants. Waller (1970), for example, used citral, geraniol and anise oil in alfalfa and Mayer & Johansen (1982) used geraniol and anise oil in apple, *Malus domestica* Borkh. (Rosaceae); pear, *Pyrus communis* L. (Rosaceae); and dandelion, *Taraxacum officinale* Weber (Asteraceae), with no increase in floral bee visitation or yield, although Woyke (1981) reported increased bee visits on onion, *Allium cepa* L. (Liliaceae), with these products.

Although a controversial area, the use of honeybee attractants continues to be of great interest to growers and beekeepers for improving crop pollination. As a consequence, a number of commercial products are in the market place. While the actual composition of some of these products may be not published for commercial reasons, they can, nevertheless, be placed into two broad categories:

- (i) Those based on bee foods, such as sugars and proteins.
- (ii) Those based on pheromones, the volatile chemicals honeybees use for communication.

Numerous studies have been conducted to evaluate the effectiveness of these commercial bee attractants. Reported results of non-pheromone attractants vary with crop and product

used, although they are generally disappointing. For example, Rajotte & Fell (1982) reported that BeeLure (Custom Chemical, USA) did not increase the attractiveness of apple blossoms to bees, and Mayer & Johansen (1982) reported that Pollenaid-D<sup>®</sup> (Crop King Chemicals, USA) was ineffective in apples, dandelion, and pears. BeeLine<sup>®</sup> (Helena Chemical, USA) has frequently been reported to be unsuccessful in a range of crops including red clover, *Trifolium pratense* L. (Fabaceae) (Burgett & Fisher, 1979), apples (Mayer & Johansen, 1982; Margalith *et al.*, 1984), pears (Mayer & Johansen, 1982), carrot, *Daucus carota* L *subsp. sativus* (Apiaceae) (Bellelli & Zani, 1981, cited Jay, 1986), cucumber, *Cucumis sativus* L. (Cucurbitaceae) (Rapp, 1981; Margalith *et al.*, 1984; Schultheis *et al.*, 1994), watermelon, *Citrullus lanatus* (Thunb.) (Cucurbitaceae) (Schultheis *et al.*, 1994; Ambrose *et al.*, 1995), and sunflower (Singh & Sinha, 1997).

The discovery of a number of honeybee pheromones and the ability to synthesise them has enabled their evaluation as attractants to aid in pollination. Some products contain only pheromone, while others contain pheromones and other compounds.

Results with pheromone-based bee attractants have been variable. Bee-Scent<sup>®</sup> (Yellowstone Intl., USA), for example, has been reported to increase honeybee foraging and fruit set in apple, cherry, pear and plum, *Pyrus domestica* L. (Rosaceae) (Mayer *et al.*, 1989), to increase the number of foraging honeybees on the day of application, but without a corresponding yield increase, in watermelons (Loper & Roselle, 1991) and to improve yield of watermelon (with increased seed number) but without increasing bee activity (Elmstrom & Maynard, 1990). However, no significant increases in bee activity or yield have been reported by other researchers in strawberry, *Fragaria × ananassa* Duch. ex Rozier (Rosaceae), (Butts, 1991), cucumber or watermelon (Schultheis *et al.*, 1994; Ambrose *et al.*, 1995). Bee-Here<sup>™</sup> (Troy Biosciences, Inc., USA) was reported to increase bee visitation and yield in sweet orange, *Citrus sinensis* L. Osbeck (Rutaceae), (Malerbo-Souza *et al.*, 2004) and raspberry, *Rubus idaeus* L cv Meeker (Rosaceae), (Neira *et al.*, 1997) but showed no increased bee activity or fruit set when tested on red clover (McGourty, 1992) and kiwi fruit (Tsirakoglu *et al.*, 1997).



Queen mandibular pheromone (QMP) contains a mixture of pheromones extracted from mated queen honeybees. Since its synthesis and commercial release, it has been used to manipulate bee hives such as for swarm prevention (Winston *et al.*, 1989, 1993), and as an attractant for pollination (Winston & Slessor, 1993), although in this latter use, results are sometimes inconclusive. It has shown promise, as its commercial product, Fruit Boost<sup>®</sup> (PheroTech, Canada), in increasing the effectiveness of bee pollination and yield in pears (Currie *et al.*, 1992a), cranberry, *Vaccinium macrocarpon* Ait. (Ericaceae), blueberry, *Vaccinium corymbosum* L. (Ericaceae) (Currie *et al.*, 1992b). On the other hand, there are reports of it increasing bee activity without any yield increase, in apples (Currie *et al.* 1992a) and cranberry (Mackenzie & Averill, 1992). Fruit Boost<sup>®</sup> has also been reported by some researchers to have no effect on bee visits, fruit size or fruit set in trials in apricots, *Prunus armeniaca* L. (Rosaceae) (McLaren *et al.*, 1992), pear and sweet cherry (Naumann *et al.*, 1994), or kiwifruit (Howpage, 1999).

In cotton plants inadequate cross-pollination may occur because of low numbers of bee visits associated with the unattractiveness of the cotton flower to honeybees (see 1.5.4). While the use of chemical attractants to improve honeybee pollination has been widely reported in other crops, no investigations have been conducted in cotton (PheroTech, per. comm., 2005). If chemical attractant(s) are shown to be effective in increasing bee activity on cotton flowers, the resulting cross pollination may increase yield and lint quality.

### **1.7 THE ROLE OF BEETLES IN POLLINATION**

Cotton is commonly regarded as a partially cross-pollinated crop (McGregor, 1976) and insects are the natural agents for pollen transfer (see 1.3). Surveys of cotton-visiting insects have been reported from a number of countries (Wafa & Ibrahim, 1959; Moffett & Stith, 1976a; Moffett *et al.*, 1978b, 1980; Tanda & Goyal, 1979c; Tanda, 1983; El-Sarrag *et al.*, 1993) with pest species, pollinators and biological control agents being the most common. Of the beneficial species, those in the order Hymenoptera were generally predominant, with Lepidoptera and beetles (Coleoptera), although relatively rare, being the next most common. Moffett (1983) observed collops, *Collops vittatus* (Say)

(Melyridae), and sap beetles, *Conotelus mexicanus* Murray (Nitidulidae), present in cotton flowers in Arizona, and suggested that they may contribute to the pollination of flowers. In Australia, a dried fruit or pollen beetle, *Carpophilus aterrimus* Macleay (Nitidulidae), is commonly found in cotton flowers in Australia (Rhodes, 2002; Llewellyn *et al.*, 2007), although its role and contribution to pollination in this crop is not known.

In the last decade, investigations conducted in a number of countries have suggested that beetles may pollinate a wide range of plant species, although the specificity of the plant-pollinator interaction may vary (Endress, 1994). In most beetle pollination, scents from flowers (Gottsberger, 1990; Gibernau *et al.*, 1999; Garcia-Robledo *et al.*, 2004) or visual cues (Young, 1986; Steiner, 1998a; Van Kleunen *et al.*, 2007) act as primary attractants.

A number of species of nitidulid, sap or pollen beetles are found in flowers, although the majority are saprophagous and mycetophagous, feeding on dried and fresh fruits, decaying fruit, fermenting plant juices, peanuts, honey, fungi, rotting vegetable matter, and plant sap (Hinton, 1945; Okumura & Savage, 1974). One species, the small hive beetle, *Aethina tumida* Murray, is a parasite of honeybee colonies and another, *Brachyepplus auritus* Murray, feeds on the wax and honey of *Trigona* spp. (Habeck, 2002). However, other nitidulid beetles, such as *Carpophilus hemipterus* L., *C. mutilatus* Erichson, *Uroporus humeralis* F., and *Haptoncus luteolus* Erichson are effective pollinators of atemoya, *Annona squamosa* L. × *A. cherimola* Mill. (Annonaceae) (Gazit *et al.*, 1982). Recent research in USA (Nagal *et al.*, 1989; Nadel & Pena, 1994), Australia (George *et al.*, 1989; Blanche & Cunningham, 2005), Colombia (Garcia-Robledo *et al.*, 2004), and Japan (Kono & Tobe, 2007) has confirmed the role of some nitidulids in pollination and has expanded the number of species involved to include *Carpophilus chalybeus* Murray, *C. freemani* Dobson, *C. marginellus* Motschulsky, *C. fumatus* Boheman, *C. maculatus* Murray, *C. oiosellus* Motschulsky, *C. dimidiatus* F, *Lobiopa insularis* Castelnau, *Colopterus posticus* Erichson, *Colopterus truncates* Randall, *Aethina* (*Circopes*) *australis* Kirejtshuk, *Brachyepplus instriatus* Kirejtshuk, and *Macrostola costulata* Reitter.

### ***1.8 HAZARDOUS EFFECTS OF INSECTICIDES ON COTTON POLLINATION***

The use of insecticides to control crop pests is not always accompanied by a significant increase in yield. One reason is their lethal effects on beneficial arthropods such as pollinators (Atallah *et al.*, 1998), or biological control agents such as predators (Salman *et al.*, 1983). Historically, cotton is one of the most insecticide-intense cropping systems (Waller, 1982), accounting for about 40% of the U.S. crop insecticides used in 1976 (Eichers, 1981), and 25% of the world's insecticides in the mid 1990s (Anon, 1995a). Since then, with the development of transgenic cotton varieties (see 1.9), these figures are likely to have decreased significantly.

These pesticide applications in cotton have been regarded as a major cause of honeybee (Moffett *et al.*, 1978b; Weaver, 1978; Waller, 1982; Robertson & Rhodes, 1992) and native pollinator (Moffett *et al.*, 1978b; Weaver, 1978) losses in the field. The seriousness of bee mortality to beekeepers lies not only in the direct loss of bees but also in the loss of opportunities for bee foraging sites, as well as pesticide contamination of honey, pollen and nectar (Wafa *et al.*, 1968a, b; Hanny *et al.*, 1983; Cabras *et al.*, 1994; Kubik *et al.*, 2000; Khan *et al.*, 2004). Honeybee foragers are often killed after they contact insecticide-treated flowers or foliage while searching for nectar or pollen (Estesen *et al.*, 1992). Moffett *et al.* (1979b) reported that all colonies in his investigations lost weight during the cotton spray season due to the heavy bee mortality.

There have been a number of reports detailing the loss of honeybees in cotton as a result of pesticide use. Moffett *et al.* (1978b; 1979a) reported that when honeybees visited cotton flowers they set seed adequately, but after insecticide application the bee visitation rate dropped by 90%, with a corresponding decline in seed set. Weaver (1978) also reported a cessation of bee activity in regularly insecticide treated cotton crops. The safe time interval after pesticide application for honeybees varies with the type of product used and environmental conditions. Stoner *et al.* (1981), for example, observed that by the second day post-treatment with methyl parathion, acephate, folex and chlordimeform, foraging had returned to normal, whereas Moffett *et al.* (1978b) reported that bee visitations did not return to their normal level until at least one week after application of

methyl parathion, toxaphene and chlordimeform. The most common insecticides used in cotton over the past several decades have been synthetic pyrethroids, many of which are also highly toxic to honeybees.

For these reasons, despite honeybees being used as pollinators in many crops, most beekeepers avoid providing bees for cotton in USA (Bennett, 1993) and Australia (Stace, 1994).

Attempts have been made to minimise the hazardous effects of insecticide sprays applied to cotton on honeybees. Timing of pesticide application is critical. Atallah *et al.* (1988) suggested that insecticides should be applied early in the cotton season before the commencement of bee foraging activity. Eisikowitch & Loper (1984) also suggested that since peak honeybee activity in cotton was between 10:00 and 15:00, insecticide sprays should be delayed until after these times. It should be noted that this would only prevent direct contact of bees with sprays, but would not prevent their contact with active pesticide residues on plants.

Locating apiaries away from direct pesticide exposure is also important in reducing bee losses. Colonies located in a treated field are likely to sustain more losses than colonies situated beyond the treated area, at the edge or outside the field (Anderson & Atkins, 1968). Moffett & Stith (1972c) found that bee mortality from parathion decreased with distance from a sprayed cotton field and that colonies in an apiary at the edge of the field suffered less damage than similar colonies located in the middle of it.

Another method is the removal of honeybee colonies at times when pesticides are to be applied. Moffett & Stith (1972a) suggested that since honeybee activity resulted in good cotton boll set early in the season, bee colonies could be removed from the cotton fields during the mid flowering season to enable insecticide use. Stoner *et al.* (1981) recommended a more practical way of achieving this; by placing hives permanently on mounted trailers and moving apiaries out of farms when insecticides were to be applied. However, many beekeepers with large apiaries do not find it economically practical or

feasible to move their colonies to pesticide-free areas kilometres away (Anderson & Atkins, 1968).

It is not always easy to move colonies away from an area before spraying, so confining bees to their colonies for varying lengths of time during pesticide application (Jaycox, 1963), feeding the bees pollen and sugar syrup, shading the hives, equipping hives with Miller bottom boards and Wardecker waterers and covering colonies with burlap are other practical alternatives (El-Khashab, 1967; Moffett *et al.*, 1977a, 1979b, 1981).

With the commercial release of Bollgard<sup>®</sup>II cotton in Australia (see 1.9), it was predicted that pesticide use would be reduced by up to 75% over conventional varieties (Anon, 2004) improving the environmental sustainability and increasing profitability of the cotton industry by up to A\$ 1.7 billion per year (Anon, 2004). In Australia, for example, overall pesticide use has been reduced by 70% in the areas where it was planted (Doyle *et al.*, 2005) and in the USA, Bollgard<sup>®</sup>II cotton has reduced the annual frequency of insecticide applications to cotton from 14.1 during 1995 (Williams, 1996) to 5.5 in 2001 (Williams, 2002).

However, in Australia, populations of secondary pests such as green mirid, *Creontiades dilutus* (Stål) (Hemiptera: Miridae), cotton aphid, *Aphis gossypii* Glover (Hemiptera: Aphididae), and thrips, *Thrips tabaci* Lind. (Thysanoptera: Thripidae), have increased in importance, requiring insecticidal control (Whitehouse *et al.*, 2005; Knight *et al.*, 2007).

**Table 1.4 Average number of sprays of various pesticides on Australian conventional and transgenic Bt (Ingard, Bollgard) cotton, during seasons 2003, 2004 and 2005** [Source: Doyle *et al.* (2005)].

Pesticide	2003		2004		2005	
	Conven.	Ingard <sup>®</sup> I	Conven.	Bollgard <sup>®</sup> II	Conven.	Bollgard <sup>®</sup> II
Fipronil 200SC	0.15	0.74	0.59	1.33	0.4	1.16
Omethoate	0.0	0.15	0.02	0.03	0.02	0.08
800SL						
Dicofol 480EC	-	-	-	-	0.01	0.02
Diafenthiuron	0.11	0.04	0.08	0.11	0.02	0.04
500SC						
Dimethoate	0.44	0.19	0.94	1.02	0.3	0.44
400EC						
Endosulfan	1.11	0.07	1.13	0.08	2.26	0.26
350EC						
Amitraz 200EC	0.19	0	2.34	0.09	1.56	0.04
Indoxacarb	1.26	0.07	2.09	0.02	1.58	0.04
Emamectin	1.19	0.11	1.86	0.02	1.8	0
Spinosad 480SC	0.30	0	0.81	0.02	0.58	0

Table 1.4 shows the average number and type of pesticide sprays applied to conventional and Bollgard (Ingard<sup>®</sup> and Bollgard<sup>®</sup> II) cotton over the period 2003 - 2005. This table shows that different pesticide regimes are applied to Bt and conventional cotton: compared to conventional cotton, there was a reduction in use of many pesticides in transgenic Bt cotton, in particular synthetic pyrethroids.

In 2004, for example, 19 previously used pesticides were not used, and a further 19 had their number of applications reduced by 40-97% (Doyle *et al.*, 2005). However, there was higher use of five pesticides in Bt cotton, namely fipronil, dimethoate, omethoate, dicofol, and diafenthiuron, although the last three products were only occasionally applied to both

types of cotton crops (Doyle *et al.*, 2005). The two more commonly applied pesticides, fipronil and dimethoate, are toxic to honeybees.

In France, fipronil was accused as the cause for the decline of sunflower honey production (Chauzat *et al.*, 2005). It is suspected that fipronil or its metabolites could migrate into nectar or pollen of treated sunflowers and induce deleterious effects in foraging bees after ingestion of contaminated food (Chauzat *et al.*, 2005). Currently, fipronil is banned (Rogers, 2004).

### **1.9 TRANSGENIC Bt COTTON**

Historically, cotton production has utilised hybrid varieties. However, with recent advances in biotechnology and genetic engineering, production of genetically modified (GM) or transgenic crop varieties is increasingly common. Transgenic crops that have evolved into commercial products in the past decade include herbicide tolerance in corn, soybeans, canola and cotton, virus resistance in potatoes and squash, and resistance to specific insect pests in corn, potatoes and cotton (Perlak *et al.*, 2001). While GM plants have been widely accepted in USA and a number of other countries, its adoption in Europe has been more limited.

The use of transgenic varieties of cotton with enhanced insect tolerance is now being adopted in many countries. These have been genetically manipulated to produce an insecticidal protein from the bacterium, *Bacillus thuringiensis* subsp. *Kurstaki* L. (*B.t.k.*), which is toxic to lepidopterous insect pests, in particular *Helicoverpa armigera* (Hübner). In 1996, Australia's first commercial cotton variety, known as "Ingard<sup>®</sup>" ("Bollgard<sup>®</sup>" in USA), containing one *B.t.k* gene *CryIAc*, was commercially released to the cotton industry.

A more recent development to replace Ingard<sup>®</sup> cotton is Bollgard<sup>®</sup> II cotton. Bollgard<sup>®</sup> II varieties contain two insecticidal protein-producing *B.t.k* genes: *CryIAc* and *Cry2Ab* (Greenplate *et al.*, 2000). Hence, Bollgard<sup>®</sup> II extended the level and spectrum of control

offered by the Ingard<sup>®</sup> and aimed to reduce the chances of resistance being developed by the target pests, particularly *H. armigera*, to these transgenic crops (Perlak *et al.*, 2001).

Bollgard<sup>®</sup>II was commercially released in Australia in 2002 and became available to cotton growers for planting from 2003 (Anon, 2004). Initial trial-scale experiments in Australia and USA indicated that transgenic Bt cotton crops provided excellent, season-long control of cotton bollworms *H. armigera* and *H. punctigera* (Wallengren), fall armyworm, *Spodoptera frugiperda* (Smith), pink bollworm *Pectinophora gossypiella* (Saunders), lesser armyworm *S. exigua* (Hübner), cotton loopers, *Anomis flava* (Fabricius), and other secondary leaf- or fruit-feeding caterpillar pests in cotton (Ridge *et al.*, 2000; Gianessi & Carpenter, 1999). Also, the plant is regarded as being as safe to the environment, humans and other non-target species, including beneficial predators and parasites, as are other commercial cotton varieties (Betz *et al.*, 2000, Malone, 2004; Whitehouse *et al.*, 2005). Furthermore, yield and quality from Bollgard<sup>®</sup>II varieties are comparable to that of conventional non- transgenic Bt varieties (Kerby *et al.*, 2000).

In the USA, transgenic cotton crops were grown on more than one-third of all cotton acreage in 2000 (Perlak *et al.*, 2001), and in Australia, adoption of Bt cotton has been rapid and widespread, and made up over 70% of the crop in 2005 (Llewellyn *et al.*, 2007).

A major concern is the flow of the transgenic genes from the GM crops into other organisms, such as weeds, bacteria and even mammals. Gene flow is a collective term that includes all mechanisms resulting in the movement of genes from one population to another. Gene flow generally occurs within a species, but examples of interspecies gene flow are known (Ferris *et al.*, 1983). The potential for gene flow from GM plants to their non-GM counterparts and, thus, the creation of unwanted GM hybrids, or to cross with wild relatives and increase their weediness by conferring a selective advantage, are major points to be considered in any GM plant risk assessment (Conner *et al.*, 2003). This is therefore an issue with the use of transgenic Bt cotton.



### ***1.10 THESIS OBJECTIVES***

This thesis reports on investigations to assess the use of honeybees for pollination of cotton crops, as well as for honeybees to utilise cotton as a melliferous crop. In spite of several studies indicating the potential benefits of pollinators to cotton production, as demonstrated from the literature review, most of the investigations on honeybees in cotton are not recent. This is probably due to the decimation of populations of pollinators near cotton fields as a result of the relatively recent excessive use of broad spectrum synthetic insecticides in cotton production throughout the world. With the introduction of Bt cotton, and the likely associated reduction in pesticide use, it appears to be propitious to investigate this area again. Although the benefits of growing Bt cotton, such as higher yields and reduced pesticide use, have been promulgated some of the risks associated with this technology remain unclear. As pointed out in Section 1.9, while there has been a significant reduction in overall pesticide use, there has been an increased use of some pesticides, particularly fipronil, especially around flowering. This, in itself, poses particular problems for honeybee pollination.

It was anticipated that this work would generate data on general pollination problems of cotton, as well as providing basic Australian information about the benefits from managed bees and potential native pollinators in cotton, and the apicultural management practices to maximise honeybee foraging activity and pollination efficacy of cotton flowers. The impact on colonies utilising cotton as their key foraging crop was also an important issue that was considered, especially for beekeepers.

This thesis further reports on investigations into the other common inhabitants of cotton flowers: pollen beetles, and in particular their likely roles in enhancing or deterring pollination.

The key aims of the thesis were:

- 1) To investigate the importance of honeybees in cotton pollination under Australian conditions, to adequately quantify the influence of pollination on yield and quality parameters such as boll weight, seed numbers, and lint in cotton (Chapters 2, 4).

- 2) To investigate honeybee foraging and pollination behaviour in cotton (Chapters 2, 4).
- 3) To evaluate methods of hive manipulation, such as increasing or decreasing colony pollen intake, to increase activity of honeybees in cotton (Chapter 2).
- 4) To evaluate the use of Queen Mandibular Pheromone to increase activity of honeybees in cotton, and as a consequence, increase fruit set and yield (Chapter 3).
- 5) To optimize honeybee pollination in cotton to the shortest period possible so that it could be incorporated into Integrated Pest Management programs in cotton (Chapter 4).
- 6) To investigate the role of pollen beetles in cotton pollination, and their influence on honeybee foraging behaviour in cotton flowers (Chapter 5).
- 7) To assess the toxicity of fipronil, the major pesticide used in cotton during flowering, to honeybees in laboratory and potted plant bioassays (Chapter 6).

**Note: While I have attempted to minimise repetition of information presented in this chapter, some has been repeated in subsequent thesis chapters for clarification or discussion of individual studies.**

## CHAPTER 2

### EFFECTS OF RESTRICTING POLLEN ENTRY, AND FEEDING POLLEN SUPPLEMENTS TO HONEYBEE COLONIES USED FOR COTTON POLLINATION

#### 2.1 INTRODUCTION

Honeybees require carbohydrates, proteins, fats, minerals, vitamins, and water to be able to rear brood (Loper & Berdel, 1980). Most of the carbohydrate comes from nectar whereas the proteins, fats, minerals, and vitamins usually come from pollen. A honeybee colony needs to collect 23-32 kg of pollen / year to meet its requirements for these substances (Todd & Bishop, 1940). The protein content of the pollen is a direct measure of pollen quality in the diet of honeybees (Pernal & Currie, 2001; Keller *et al.*, 2005). Colony growth can be limited by either a lack of pollen or by the available pollen not containing the necessary nutrients. Moreover, it has been found that fresh pollen containing a high protein content is important in the development of the hypopharangeal glands of worker honeybees (Haydak, 1970) that secrete the royal jelly to feed the young larvae. The pollen-gathering activities of honeybees from different plant species have been widely studied, for example by Rashad & Parker (1958), Eckert (1942), Synge (1947), Percival (1955), Thorp (2000), Goodwin (1986), Buchmann & Shipman (1990), and Free (1993), who reported that the availability, quantity and nutritive value of pollen varies between plant species.

Colony pollen intake rates vary in response to changes in brood levels (Free, 1967; Jaycox, 1970; Doull, 1973; Fewell & Winston, 1992; Eckert *et al.*, 1994). The magnitude of flight activity and pollen collection by a colony has been correlated with the amount of its brood rearing. According to Lindauer (1953, 1955) all field activities and the division of labour of the field force (nectar, pollen, and water gathering) are regulated by the needs of the colony. For example, if the colony has a large quantity of brood to feed and is short of pollen, more of the field force will gather pollen. Individual workers may also

change their behaviour by collecting larger loads of pollen when colonies have large areas of brood to support (Eckert *et al.*, 1994) or if they have low pollen stores (Fewell & Winston, 1992).

Pollen provision stimulates egg production by the queen, and thus more larvae, which in turn, leads to an increased demand for pollen. Practically, supplementary feeding of colonies increases brood rearing activity (Forster 1968a, b; Doull, 1980a; Reid, 1973; Waller *et al.*, 1981a), and lifespan of foragers (Winston *et al.*, 1983), hence a large brood area in a colony is likely to be indicative of high pollen demand.

On the other hand, other authors suggest that increasing protein sources within the hive by providing pollen to colonies as supplementary pollen or substitutes to natural pollen may increase brood rearing activity. This would, in turn, mean that colonies will need more pollen to feed their brood and this may stimulate bee foragers to increase their flight activity, collecting pollen from the target crop (Barker, 1971; Goodwin *et al.*, 1994; Pankiw *et al.*, 1998; Pankiw 2004; Saffari *et al.*, 2004). Several studies have confirmed that colonies fed pollen supplements produce more brood than unfed colonies (Forster 1968a, b; Standifer *et al.*, 1971; Waller *et al.*, 1981a). Colonies fed supplements may also collect more honey than unfed colonies (Palmer-Jones, 1947; Purdie & Doull, 1964).

Free (1967) reported that while feeding pure pollen to a colony can increase nectar collection, it reduces the amount of pollen collected. However, it appears that if non-pure pollen (e.g. pollen supplements or substitutes) are fed to colonies, field pollen collection may not be reduced (Free & Williams, 1971). Moeller (1972) reported that the percentage of corn pollen gathered by colonies which received pure pollen was only 4.3%, compared with 40% for colonies receiving pollen/soybean flour supplements, and 53.4% for colonies receiving nothing. Based on the above findings, it appears that feeding pollen supplements or substitutes may be a possible way of stimulating brood rearing activity and increasing pollen-gathering activity.

It has also been suggested that honeybee pollination efficacy might be increased by using pollen traps. Traps may increase bee foraging activity (number of in-coming bees / min) (Webster *et al.*, 1985), or even if the activity remains the same, can increase the proportion of pollen gathering bees (Liven & Loper, 1984; Thorp, 1979; Webster *et al.*, 1985). Rashad & Parker (1958) stated that pollen traps with 53% efficiency increased pollen collection of colonies by 80%, and Hirschfelder (1951), Lindauer (1952), Rybakov (1961), Moriya (1966) and Chambers (1985) reported similar findings.

Honeybees typically reject cotton pollen as a resource. The purposes of this study were to evaluate the potential to stimulate bees to increase pollen foraging and enhance pollen collection, thus overcoming this rejection. In this study I investigated the effects of the two options for manipulating hive nutrition; namely maximizing pollen intake by feeding supplementary pollen to colonies, and minimizing pollen intake by fitting colonies with pollen traps. I assessed their effects on overall colony performance, and also whether these strategies encouraged honeybee workers to increase their foraging activity, particularly for cotton pollen.

This chapter presents outcomes from observations and experiments conducted to find more definitive answers on:

- (1) The effectiveness of supplementary feeding of colonies on honeybee pollen collection and efficacy, as well as directly on the colony.
- (2) The effectiveness of pollen traps on honeybee pollen collection and pollination efficacy
- (3) The role and impact of honeybees in cotton pollination.
- (4) The attractiveness of cotton flowers and pollen to honeybees.
- (5) The importance of cotton as a melliferous plant.

## **2.2 MATERIALS AND METHODS**

### **2.2.1 Location**

Two experiments were conducted on a two hectare commercial irrigated transgenic Bt (Bollgard II® Sicot 71BR) cotton crop at the Australian Cotton Research Institute (ACRI)

at Narrabri (30.30°S, 149.8°E), in one of the major cotton growing areas in NSW, Australia. The cotton was planted in rows running east to west, with 1 m spacing between rows (approximately 100,000 plants / ha). The crop was planted on 20 December 2004 and was regarded as a late season crop (normal planting time is late October). The crop was subjected to normal agronomic management but no pesticides were applied in the period immediately prior to, or in the presence of, bee colonies. The use of a late season cotton crop for the study was to ensure that the peak flowering period of the cotton crop at the study site did not coincide with the surrounding cotton crops in the nearby area. This was to ensure that the managed bees foraged only on the cotton crop at the study site and not on surrounding cotton crops which are treated extensively with synthetic insecticides.

The investigation used 16 honeybee colonies, which were moved adjacent to the cotton crop on 4 March 2005. The colonies were headed by mated sister queens of the Italian strain of the European honeybee (*A. mellifera ligustica*), supplied by Jones Apiaries (Dubbo, NSW) and housed in Langstroth hives (Dadant, 1992), each having two deep brood chambers and an empty super. The colonies were equalized for sealed brood, stored pollen and honey prior to the experimental period. They were set in one group on the ground without shading, which is common practice for beekeepers in this area, because maximum temperatures do not get as high as in other cropping areas. Irrigation water in furrows or water from the Namoi River was always available to the bees within a 100 m radius. Two potential outcomes of treatments were investigated, viz. (i) the effect of feeding colonies and/or trapping pollen on colony parameters, (ii) the effect of manipulating colonies pollen intake on cotton pollination. Field data were taken from 5-30 March 2005.

## **Experiment I**

### **2.2.2 Treatments**

The colonies were arranged in a completely randomised design (CRD) with four replicates. The effect of (1) feeding supplementary pollen and (2) pollen restriction (by

pollen traps) were tested as factors, with two treatments (provision and non-provision) in each factor.

Thus, the 16 colonies were allocated into four groups:

- (i) Four hives: pollen feeding, no pollen traps.
- (ii) Four hives: pollen feeding, pollen traps.
- (iii) Four hives: no pollen feeding, no pollen traps.
- (iv) Four hives: no pollen feeding, pollen traps.

Pollen supplements (protein patty) were provided as a flat “cake” placed on the top bars of the hive just above the brood nest (Taber, 1973; Reid, 1973). The common patty used by Australian beekeepers (Duncan per. comm., 2004) was used in these experiments. It was prepared as a cake made of: one part (by volume) commercial irradiated pollen of marri, *Corymbia calophylla*, (Hornsby Beekeeping Supplies, Hornsby 2077, NSW): five parts commercial cane sugar: five parts soybean flour (Meriram, Everton Hills 4053, Qld). These ingredients were moistened sufficiently with two parts of water to hold the materials together (Cook, 1985).

A 500 g patty was given to each colony in groups (i) and (ii) on 5, 11, 18 and 25 March 2005. The protein patty was weighed every week and replaced with a fresh patty. Consumption of these patties was estimated on the differences in weight between the amount of patty placed in the hive and the uneaten portion remaining in the hive. While this methodology does not take into account the loss of moisture from the patty, this method has been commonly used to estimate pollen cake consumption (Forster, 1966; Cook, 1985; Saffari *et al.*, 2004).

Western Australian designed pollen traps (Rhodes, 2002) supplied by Jones Apiaries, Dubbo, NSW (similar to O.A.C. traps; Waller, 1980) were fitted to hives in groups (ii) and (iv) on the same day the honeybee colonies were introduced to the experimental site.

The most important variables in honeybee colonies are the amounts of adult bees, brood, stored honey, harvested pollen (as measured by using pollen traps) and stored pollen. To

understand how a honeybee colony functions, it is necessary to observe how these factors change and interact with each other throughout the season. In the current study, colony parameters measured during the cotton season were: (1) bee flight activity as an indicator of field foraging activity; and (2) pollen gathering activity, (3) brood rearing activity and (4) nectar gathering activity, as indicators of pollination efficacy.

### ***2.2.3 Flight activity***

Flight activity is a sensitive indicator of foraging conditions in the field as well as the ability of colonies to exploit available food sources. The method used to assess flight activity in these investigations monitored out-going bees from hives, and employed a technique described by Gary (1967), which comprised a portable, lightweight cone made of 8-mesh galvanized wire which was constructed sufficiently large ( $40 \times 50 \times 70$  cm) to completely cover the hive entrance-exit without being affixed to the hive (Figure 2.1). This flight-counting cone was lifted on the hive entrance for 30 sec, then moved 1 m away and totally covered with thick black cloth except for an upper small ( $1.5 \times 10$  cm) exit hole at the cone tip. Out-going bees normally fly upwards and are attracted to light (Gary & Lorenzen, 1988); thus they flew from the colony and exited through the opening where they could be counted visually, and were recorded as the number of bees departing the hive / 30 sec. Six counts were made in a 2 h interval from 08:00 to 18:00 (Eastern Australian daylight saving time, EADST) on 9, 14 and 21 March 2005. These data enabled determination of:

- (i) The effect of key factors on bee flight activity.
- (ii) Seasonal flight activity.
- (iii) Diurnal flight activity.



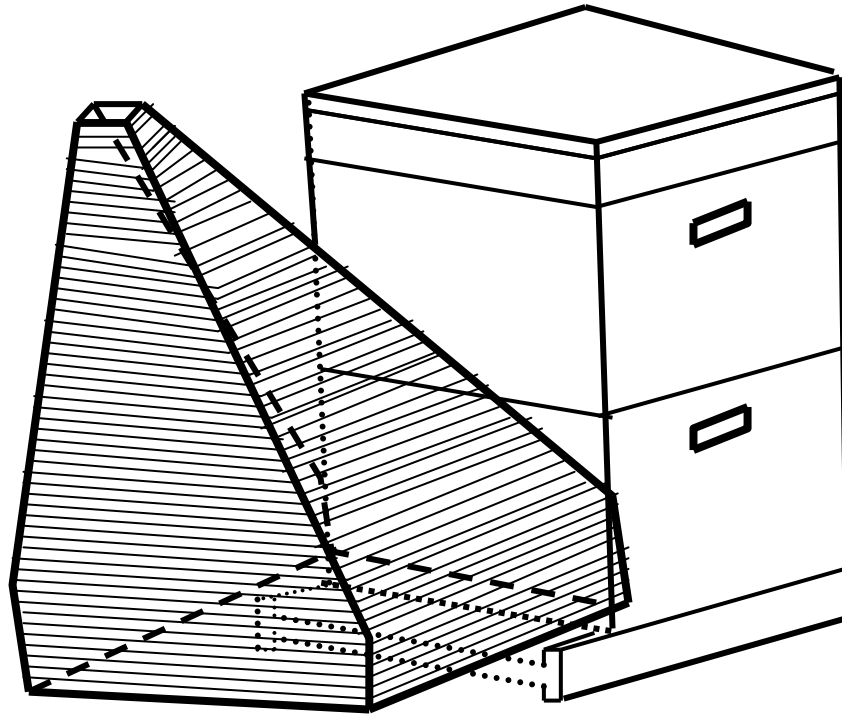

Figure 2.4 Portable wire cloth cone for counting honeybees as they fly out from a colony [Source: Gary (1967)].

#### **2.2.4 Pollen gathering activity**

Pollen collection was measured by two different techniques: (1) trapping pollen and (2) assessing area of stored pollen in the hives.

##### **2.2.4.1 Trapping pollen**

The pollen load of bee foragers is a good indicator of the surrounding flowering plant species that provide pollen sources for the honeybee colonies (Dimou & Thrasylvoulou, 2007). The pollen loads also reflect the availability of the dominant pollen resources for the honeybee foragers (Olsen *et al.*, 1979).

Pollen collection was determined using eight colonies provided with pollen traps (see 2.2.2) with an assessed 30% trapping efficiency. Pollen trap efficiency was measured during the flowering season by counting 100 bees entering the hives with pollen loads on their hind legs. The trap was then emptied of pollen and the percentage efficiency of the

trap was calculated by dividing the number of loads (viz. 2 pellets per load) on the collecting tray by the number of bees entering with pollen loads (Loper *et al.*, 1984).

The amount of pollen trapped daily by honeybee colonies fluctuates considerably, probably due to the interaction of climatic and floral factors (Percival, 1947; Synge, 1947; Rashad & Parker, 1958; Goodwin & Perry, 1992). When, however, the implications of pollen intake of the colonies are considered it is better to examine trends rather than daily fluctuations (McLellan, 1976). Therefore, harvested pollen from colonies in Treatments ii and iv was collected weekly from the tray of the traps on 11, 18, 25 and 30 March 2005, in order to monitor the amount and the sources of pollen collected by bees in the field. Samples were taken to the laboratory and the following were assessed:

(i) *Quantity of trapped pollen*

The amounts of wet trapped pollen pellets from treated and control colonies were determined by weighing them, using a digital balance (PB403-S, Mettler Toledo, Switzerland). This enabled determination of (i) amounts of weekly collected pollen (trapped pollen); and (ii) the effects of pollen supplementary feeding on pollen foraging activity and subsequent pollen collection.

(ii) *Quantity of cotton pollen*

The number of cotton pollen pellets (and its relative %) within the trapped pollen was determined by visual and microscopic examination (see below) of selected samples. This enabled determination of honeybee preference for cotton pollen, compared with non-cotton pollen.

(a) Visual examination

A sample of 50 mL of pollen was randomly taken from the trapped pollen, mixed from all colonies, each week during the study for identification. The pollen pellets were separated, based on morphological characters. They were first sorted visually depending on their colour and size. Then, a representative sample of each type of pollen pellet was taken for microscopic examination (Rashad & Parker, 1958) for botanical identification. In

addition, identification was made by observing the colour of the pollen loads on the bees working on flowers. A reference pollen collection was made by collecting honeybees foraging on cotton and other flowers near the cotton field. The homogenous pellets were weighed and multiplied by the proportion of each type of pollen present, to estimate the weight of pollen collected from each plant species (Dimou & Thrasyvoulou, 2007).

(b) Microscopic examination

A sample of ripe pollen grains was collected directly from cotton flowers from the field, and a reference slide of cotton pollen was prepared. The ripe pollen grains were shaken directly onto a microscopic slide. In order to enhance the transparency of the pollen grains, a drop of distilled water was added. The slides were then covered with a cover slip and examined under an Olympus BX60 stereomicroscope with ProgRes<sup>®</sup> JENOPTIK C14 Plus Digital Camera at 400X magnification.

(c) Electron microscope examination

Individual grains of the major pollen sources were examined under scanning electron microscopy to identify their morphology and size. These were compared to cotton pollen. The pollen samples were dried in desiccators with silica gel for 1 d, and a small amount of this pollen was placed on double-sided tape on a stub and coated with gold in a sputter coater. All the samples were viewed in a Philips XL30 Scanning Electron Microscope at 10 kv.

***2.2.4.2 Area of stored pollen***

Pollen loads delivered by foragers from the field are deposited directly into comb cells close to brood nest, and then nurse bees use the stored pollen to feed the brood, while the excess pollen remains stored (Winston, 1987). A grid frame is commonly used to determine the quantity of brood, pollen and honey (Jeffree, 1958); however, this method is time-consuming especially if large numbers of hives are to be assessed. Moreover, this technique would not be practicable during hot days because of the detrimental effect of high temperatures on young, unsealed brood. In this study, measurements of pollen quantity were taken by estimating the area of cells stored with pollen in the combs of the

colonies. In addition to the pre-treatment measurements on 5 March, two further measurements were taken, on 18 and 30 March, 2005.

The determination of area of stored pollen was made by removing the combs from each hive in turn, and shaking all bees off each comb (each comb was carefully inspected for presence of the queen before shaking; when she was located the queen was transferred gently) into her hive box. Each comb was then placed on a modified artist's easel, and each side was photographed with a digital camera (Caplio GX, RICOH). All photos were subsequently downloaded onto a computer, and image analyzing software (Image Pro Plus version 3.0, Media Cybernetics Inc., Silver Spring, Maryland, USA) was used to estimate the area (in  $\text{cm}^2$ ) within a trace of the outline of the stored pollen in each image. The sum of the pollen areas of all combs in a hive was regarded as the total area of stored pollen for that hive.

#### ***2.2.5 Brood rearing activity***

The area of brood is regarded as a sound basis for grading colonies for use in pollination services (Todd & Reed, 1970; Loper, 1982). Measurements of brood rearing activity were taken by estimating the area of sealed brood (pupal stage) of worker bees in colonies at 12 d intervals (Rashad & Parker, 1958) (the life cycle of a worker bee is 3, 5, and 13 d as egg, larva and pupa, respectively, and adult bees emerge after 21 d). Therefore, on any observation day, pupae could be up to 1 d old. Hence after 12 d all the older sealed brood would have emerged and the existing area of sealed brood would therefore be the brood which has been exposed to the treatments.

The determination of the brood area was made using the same images of combs described in assessment of area of stored pollen (see 2.2.4.2). Thus the area of sealed brood ( $\text{cm}^2$ ) in each comb was determined by using the same technique but by tracing the outlines of the sealed brood on the image (Figure 2.2). The sum of the sealed brood area of all the combs in a hive was regarded as the area of sealed brood for that hive.

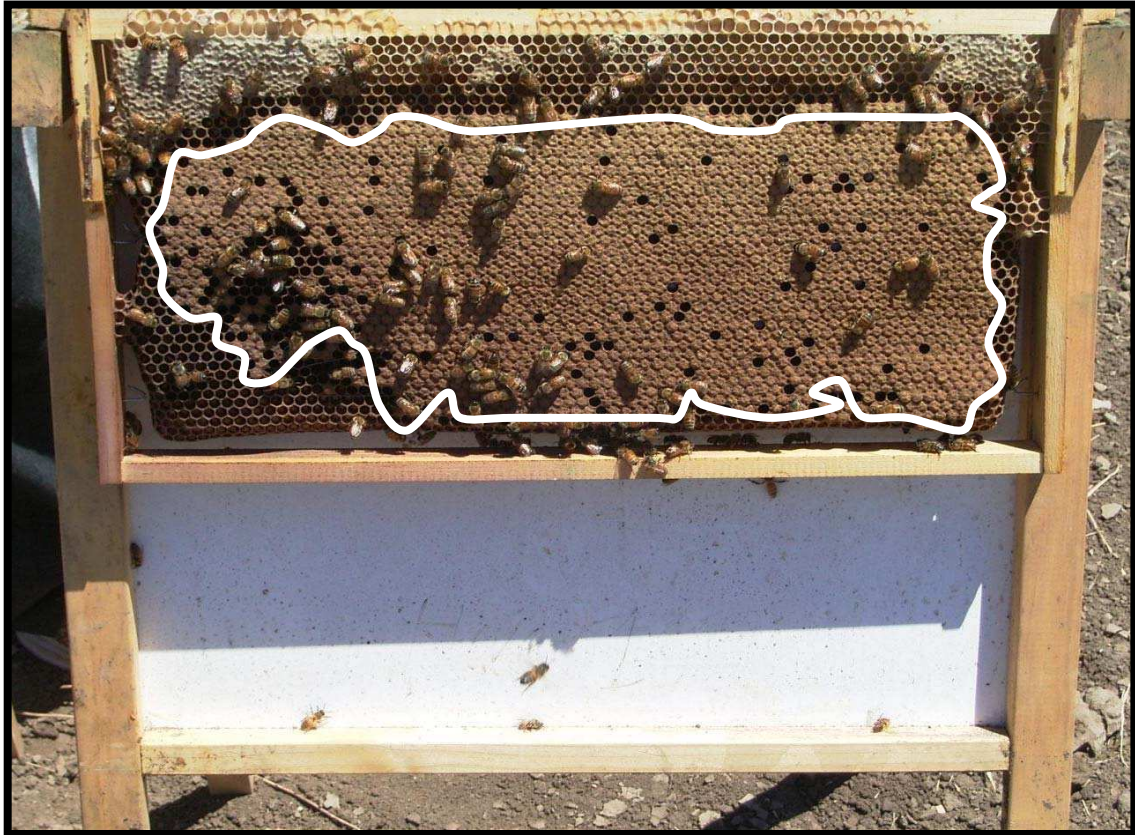

**Figure 2.2** Photographed frame of *A. mellifera* used to assess the area occupied by sealed brood (with trace line). Area of stored pollen was assessed similarly.

### ***2.2.6 Nectar gathering activity***

The quantity of nectar gathered by honeybee colonies was determined by assessing the honey produced by individual colonies. The change in hive weight is considered to be a good indicator of the amount of honey collected in a hive (McLellan, 1977). Each hive was weighed using a digital portable hive scale (Model FS-30KA, A & D Mercury Pty Ltd, 32 Dew Street, Thebarton SA 5031, Australia), to monitor the honey flow into colonies during the cotton flowering season at the experimental site. The weight gain was determined by subtraction (Duff & Furgala, 1986). Data were taken on 5 (pre-treatment), 11, 18, 25 and 30 (post-treatment) March 2005 for progressive honey flow, whereas pre- and post-treatment weights were used to assess the overall effect of treatments on honey collection during the investigation period.

## **Experiment II**

### ***2.2.7 Honeybee pollination efficacy***

Crop yield may be used as an indicator of the pollination efficacy of a pollinator; but observations of flower visiting behaviour and the frequency of these visits are supportive evidence of its pollinating role. In this trial, both bee flower visits and cotton yield were assessed to achieve a comprehensive understanding of the pollination role of honeybees on cotton.

#### ***2.2.7.1 Foraging activity of honeybee visitors to cotton flowers***

To assess the bee visitation rate to cotton flowers, three rows of cotton at distances of 50, 75 and 100 m from the apiary were selected. Nine plots, each 15 m long and approximately 5 m apart, were marked out along each row using 2 m long plastic pegs, providing a total of 27 plots (Figure 2.3). Visual counts of the number of honeybees visiting cotton flowers were carried out every 2 h between 08:00 and 18:00 (EADST). Data were taken on 11, 19 and 23 March 2005. I defined pollinating bees as those which visited and entered flowers (infloral bees), and therefore were likely to contact pollen, and foraging (non-pollinating) bees as those which did not enter flowers, but may have collected floral nectar from outside flowers or nectar from extrafloral nectaries. The number of infloral honeybees and their type of foraging was recorded, these were assessed as pollen- or nectar-, or both pollen- and nectar-gatherers, based on their foraging behaviour and the presence or absence of pollen in their corbiculae. In addition, the numbers of non-pollinating honeybees (foragers) were recorded. The bee visits were assessed as described by McGregor (1959) thus:

“The number of bee visits is determined by an observer walking down the row and glancing at each open flower. If ten bees are seen when looking briefly at 100 flowers, the visitation rate is said to be 10%”.

Hand tally counters were used to assist with counts. During the assessments, any non-*Apis* visitors to cotton flowers were also recorded. These assessments enabled determination of:

- (i) Bee foraging behaviour.
- (ii) Bee visitation rate to cotton flowers.
- (iii) Diurnal pattern of bee visitation to cotton.
- (iv) Non-*Apis* pollinators.

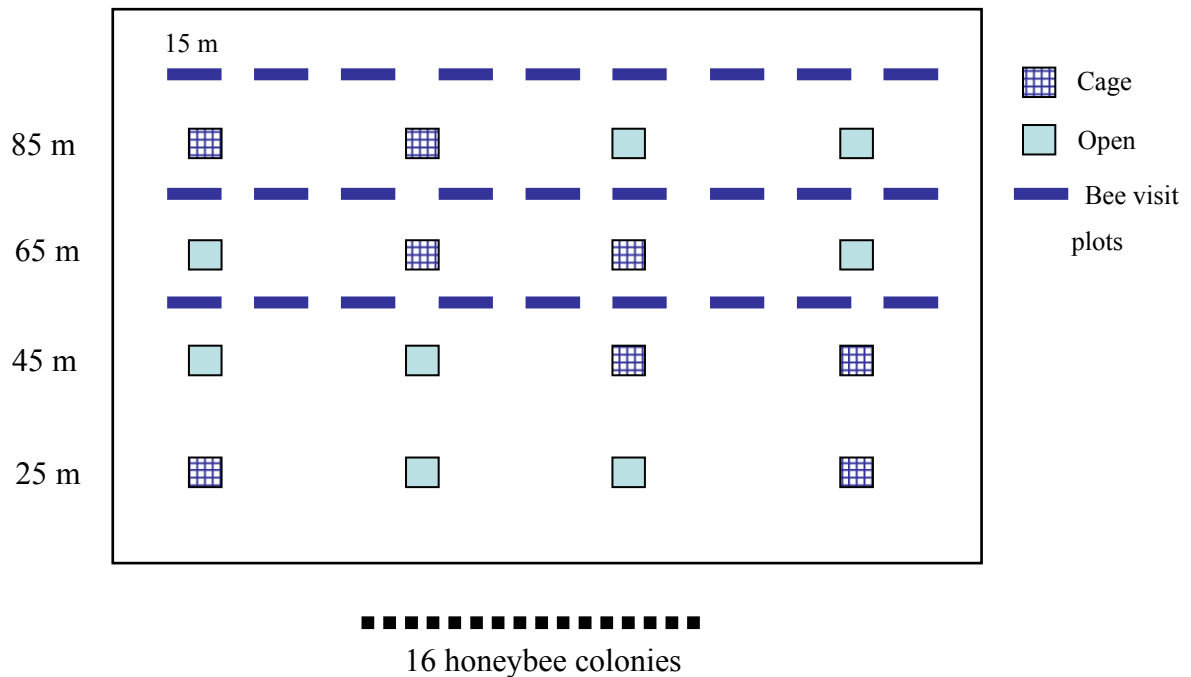

**Figure 2.3** Experimental design of the 2 ha field investigation site, with location of eight caged and eight open plots used to assess the pollination efficacy of honeybees, and 27 plots (15 m long) used to determine bee visitation rates to cotton flowers.

### 2.2.7.2 Cotton yield measurements

Cotton yield was used to assess the pollination efficacy of honeybees. This experiment was conducted in the same field as experiment (2.2.1) using the same apiary (16 colonies). The treatments evaluated were (1) no bees and (2) access of bees to cotton flowers.

#### 1. No access to honeybees

In this treatment, honeybees and other insects were excluded from cotton flowers by caging the cotton plants in the plots. Cages measuring  $3 \times 3 \times 2$  m were erected on 4

March 2005, when the cotton crop was flowering. The metal frames of the cages were covered with white mesh (2 mm) to exclude insects. Each cage enclosed three rows of cotton (approximately 90 plants) and was separated from the nearest cage by 50 m; these were regarded as control plots.

## 2. *Open access to honey bees*

Plots of identical size to the control plots (3 × 3 m) were exposed to the managed honeybees (at a rate of 8 colonies / ha), as well as to other possible pollinators.

The effect of honeybee pollination of cotton was estimated by using a total of 16 similar plots, established in four sets of two plots / treatment at 25, 45, 65, 85 m distance from the apiary location (Figure 2.3). Plots were 50 m apart from each other. Each treatment comprised eight replicates in a completely randomized design. Cages were set on 4 March 2005, one day before the bees were introduced to the site. On the same day, plants in each plot were tagged with small plastic tags which were securely fastened to branches at the base of newly opened flowers, in order to differentiate the flowers which had been produced before the arrival of honeybee colonies and those which were exposed to honeybees. The presence of these early bolls would have otherwise confounded the treatment effects.

Honeybee colonies were introduced into the cotton field on 5 March 2005. To minimize cage effects, all cages were dismantled immediately after the flowering period, i.e. approximately 25 days after setting up. Hand-harvesting of mature cotton bolls in each plot was undertaken when they had fully matured, on 30 May 2005. Bolls that were unable to mature because of cold temperatures were excluded from the counts. The mature bolls with lint counted, placed in paper bags, and transported to the ACRI laboratory for processing. In the laboratory, cotton samples were ginned using a mechanically operated cotton gin and the weight of samples from each replicate plot was taken. Unfortunately, in the laboratory, to reduce the number of measurements needed to be taken, samples were made by combining bolls of the two similar plots in the same row



(viz. treatment or control) for analysis. This effectively meant that the number of replicates for this part of the investigation was halved to four / treatment.

#### ***2.2.8 Determination of the cotton flowering pattern***

The average number of flowers in the experimental field was determined by averaging the total number of freshly opened flowers in all 27 study plots (see 2.2.7.1). Data were taken on a weekly basis.

#### ***2.2.9 Determination of other species of flowering plants within the experimental area***

As there was likely to be competition from abundant and highly attractive non-target pollen and nectar sources within the flight range of the bees in this experiment, all melliferous plants within the vicinity (500 m) of the trial site that were flowering at the same time as the cotton were detected by carefully and regularly observing honeybee activity on flowers. The flowering plants observed with significant honeybee activity were identified.

#### ***2.2.10 Recording meteorological conditions during the investigation period***

Air temperature and relative humidity are key climatic factors that influence honeybee activity and cotton plant biology (such as nectar secretion and pollen viability). These parameters were measured at the apiary site throughout the investigation period using a data logger (Tinytag®, Hastings Data Loggers, Port Macquarie 2444, NSW), which was located in the shade at a height of two metres at the edge of the cotton field. Data were logged every 15 min.

#### ***2.2.11 Statistical analysis***

Data were analyzed using ANOVA, General Linear Model, SPSS statistical package (SPSS, version 14, 2007). Prior to analysis each variable was visually tested for normality using P-P plot and Levene's test was used to test the assumption of equality of error variance (Levene, 1960). Wherever multiple sampling over time was performed, data were analysed using the repeated measures general linear model to check for interactions between factors and the time of sampling. Interactions were significant for all parameters

tested except flight activity. Consequently all parameters except flight activity were analysed using analysis of variance general linear model for each sampling time separately. For flight activity, data were averaged over the sampling period and then analysed using the analysis of variance general linear model.

Ryan's Q test was used to separate treatment means if data met the assumption of equality of variance and Dunnett's T3 test was used if the assumption of equality of variance was not met after appropriate transformation of data. In all cases, significance was accepted at the 0.05 level. The values are normally presented as mean  $\pm$  standard error (SE) of the mean (Tables), or bars (Figures).

## **2.3 RESULTS**

Statistical analysis showed that there was an interaction between time and the two factors (i.e. pollen supplements and pollen traps), but no interaction between the two factors in all parameters, except flight activity in third week. Therefore, results from each factor are presented separately.

### **2.3.1 Influence of provision of supplementary pollen on honeybee activity**

The initial measurements prior to provision of pollen showed no significant differences in the mean areas of stored pollen ( $F_{1,12} = 1.325$ ,  $P = 0.272$ ), sealed brood ( $F_{1,12} = 1.127$ ,  $P = 0.309$ ), and hive weight ( $F_{1,12} = 0.001$ ,  $P = 0.971$ ) between the control colonies and those to which pollen patties were provided.

#### **2.3.1.1 Flight activity**

The number of out-going bees in treated colonies provided raw data used to assess the following:

##### **(i) Total flight activity**

The overall number of out-going bees over the entire investigation period (monitored on 9, 14 and 21 March 2005) from colonies which received pollen supplements averaged 41.0 bees / 30 sec / colony, significantly ( $F_{1,92} = 5.498$ ,  $P = 0.021$ ) higher than the mean

flight activity of control colonies at 34.5 bees / 30 sec / colony. While there was a trend towards this result for each of the three observation days, only on 9 March was the difference significant ( $F_{1,87} = 8.364$ ,  $P = 0.005$ ) (Figure 2.4). The analysis showed there was a significant interaction ( $F_{1,87} = 7.111$ ,  $P = 0.009$ ) between factors (feeding pollen and pollen trapping) on 21 March 2005; therefore these treatments are presented separately in Figure 2.4. They show that the mean number of bees /30 sec / colony was 45.4 for those fed pollen patty with no pollen trap (F - T); 35.1 for those unfed with pollen traps (U + T); 31.6 for those fed pollen patty with pollen traps (F + T); and 29.9 for the control (U - T). Colonies from the treatment fed pollen patties and with no traps (F - T), had significantly higher flight activity than all other treatments, but there were no significant differences between the other three treatments.

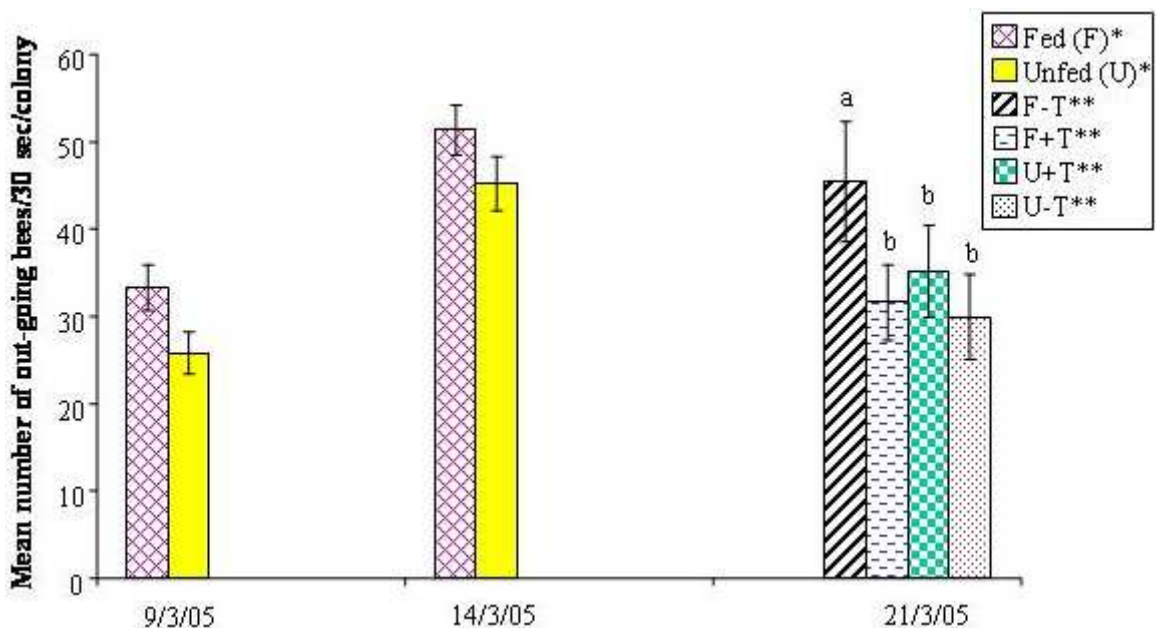

**Figure 2.4 Mean honeybee flight activity (number of out-going bees /30 sec /colony) in colonies fed weekly with 500g pollen supplement patties and unfed (control) colonies.**

\* Mean of 8 replicates

\*\* Mean of 4 replicates

\*\* F - T: fed pollen patty with no pollen trap; F + T: fed pollen patty with pollen trap; U + T: unfed pollen patty with pollen trap; U - T: control

\*\*\* Data are average of counts taken each day at 8:00, 10:00, 12:00, 14:00 and 16:00.

### 2.3.1.2 Pollen gathering activity

#### (i) Quantity of trapped pollen

The total weight of trapped pollen during the experimental period was 3367.94 g and 3432.45 g from fed and unfed colonies respectively, with mean pollen incomes of 32.5 and 33.3 g / day / colony from fed colonies and unfed colonies, respectively. However, the slightly higher total weight of pollen trapped in the control colonies was not significant ( $F_{1,30} = 0.043$ ,  $P = 0.837$ ).

The weekly weight of trapped pollen from colonies fed supplementary pollen averaged 194.7, 285.1, 272.2 and 89.8 g / colony on 11, 18, 25 and 30 March 2005, respectively, while it was 161.5, 318.7, 277.8 and 105.6 g / colony from unfed colonies on the same dates.

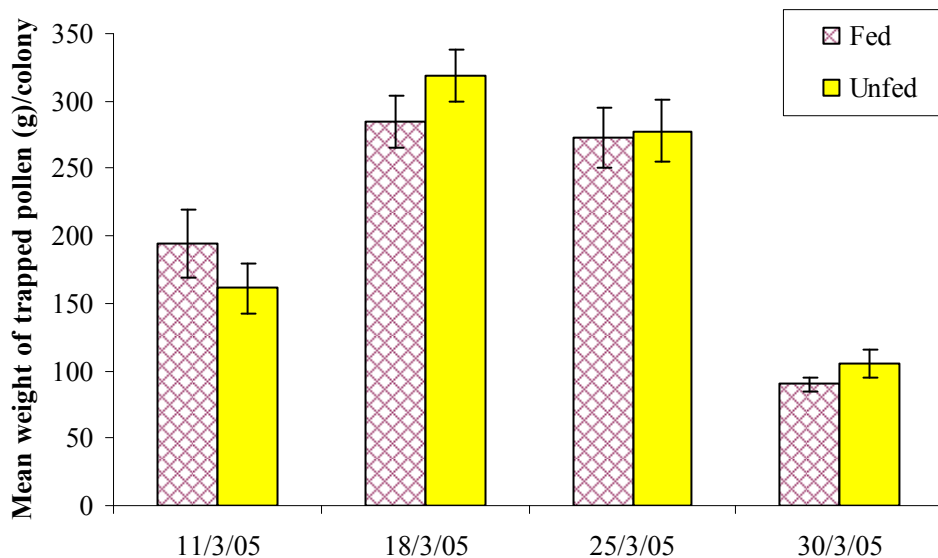
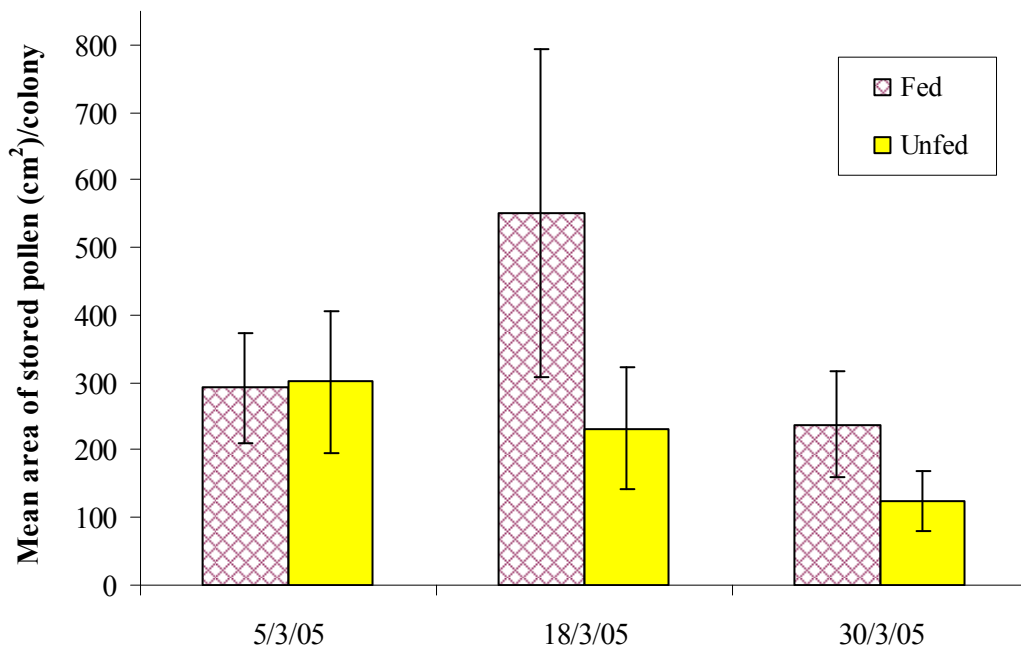

**Figure 2.5 Mean weight of trapped pollen (g) from colonies fed weekly with 500 g pollen supplement patties and unfed (control) colonies (n=4), during the investigation period 5-30/3/2005. The traps were initially set on colonies on 5 March, and the first pollen measurement was taken on 11 March, 6 d later.**

Figure 2.5 shows the comparison between the mean weights of trapped pollen from fed and unfed (control) colonies during the investigation period, and also provides a pattern of the pollen flow into colonies. There were no significant differences in the weights of weekly trapped pollen between the two treatments, on 11 March ( $F_{1,6} = 1.120$ ,  $P = 0.331$ ), 18 March ( $F_{1,6} = 1.506$ ,  $P = 0.266$ ), 25 March ( $F_{1,6} = 0.031$ ,  $P = 0.865$ ), and 30 March 2005 ( $F_{1,6} = 1.980$ ,  $P = 0.209$ ).

**(ii) Area of stored pollen**

The pre-treatment (5 March 2005) in-comb stored pollen area averaged 291.9 and 301.0  $\text{cm}^2$  / colony in the feeding treatment and control colonies, respectively (Figure 2.6), which was not significant between the two groups. Following imposition of the treatment, the mean areas of stored pollen became 551.0 and 238.2  $\text{cm}^2$  / colony in colonies fed supplementary pollen, and 232.3 and 125.5  $\text{cm}^2$  / colony in unfed colonies, on 18 and 30 March 2005, respectively.

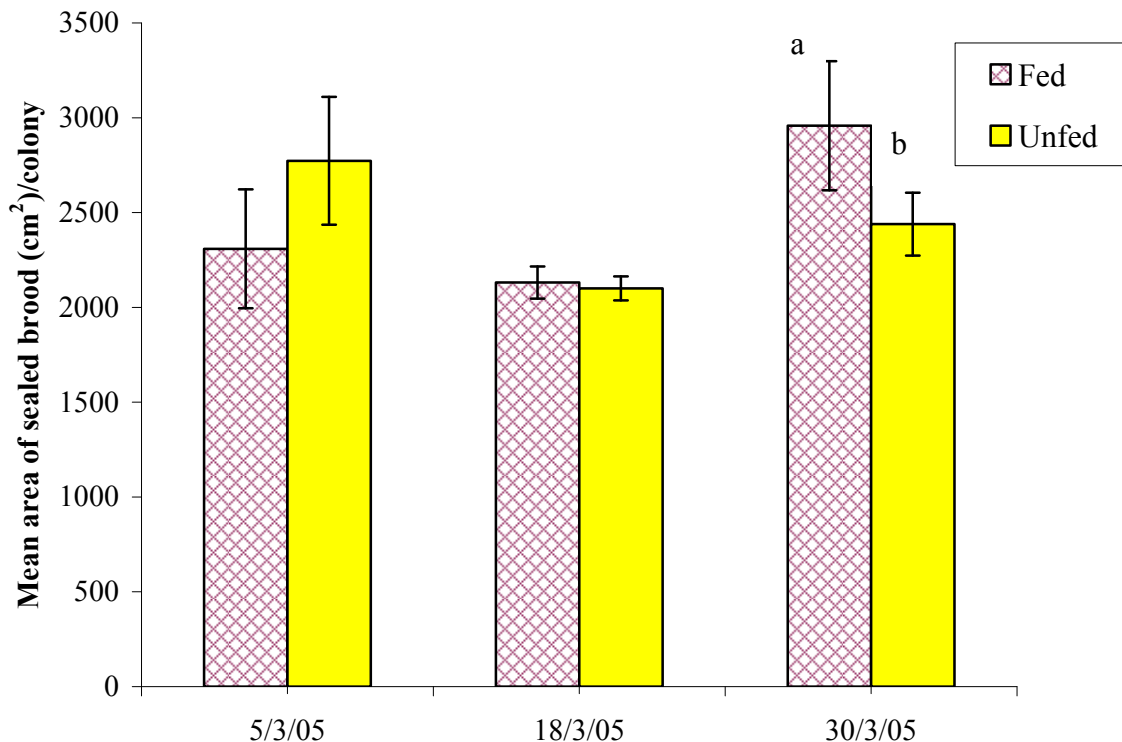

**Figure 2.6 Mean area of stored pollen ( $\text{cm}^2$ ) in colonies fed weekly with 500 g pollen supplement patties and unfed (control) colonies ( $n = 8$ ). The traps were initially set on colonies on 5 March (pre-treatment measurement).**

Figure 2.6 shows there was a greater mean area of stored pollen in pollen-fed colonies, however, this difference was not significantly superior to control colonies in either the first (+137.2%) ( $F_{1,12} = 3.887$ ,  $P = 0.072$ ), or the second (+89.8%) ( $F_{1,12} = 2.374$ ,  $P = 0.149$ ) period.

### 2.3.1.3 Brood rearing activity

The pre-treatment (5 March 2005) mean areas of sealed worker brood (Figure 2.7) were 2309.8 and 2773.6 cm<sup>2</sup> / colony in the feeding treatment and control colonies, respectively. This difference was not significant. Following imposition of the treatment, the mean areas of sealed brood were 2131.8 and 2958.9 cm<sup>2</sup> / colony in pollen fed colonies and unfed colonies on 18 and 30 March 2005, respectively. For March 18, the difference was not significant ( $F_{1,12} = 0.093$ ,  $P = 0.765$ ), but for March 30 the area of sealed brood in pollen fed colonies was significantly greater (+22.4%) ( $F_{1,12} = 4.63$ ,  $P = 0.05$ ) than in unfed colonies.



**Figure 2.7 Mean area of sealed brood in honeybee colonies fed weekly with 500 g pollen supplement patties and unfed (control) colonies (n=8). The traps were initially set on colonies on 5 March (pre-treatment measurement).**

#### ***2.3.1.4 Nectar gathering activity***

The pre-treatment (5 March 2005) mean hive weight was the same (38.5 kg) in the feeding treatment and control colonies. Following imposition of the treatment, mean hive weight was 36.8 and 37.4 kg in fed colonies and unfed colonies, respectively, on 30 March 2005. This difference was not significant ( $F_{1,12} = 0.167$ ,  $P = 0.690$ ).

Normal honey flow was determined from the weekly quantities of honey produced in control colonies (not subject to any treatment, U-T) during the study (as measured by changes in hive weight). The mean hive weights were 38.8, 38.2, 37.3, 37.2, and 39.1 kg on 5, 11, 18, 25 and 30 March 2005, respectively. The differences in mean hive weight from the pre-treatment weight ( $n = 4$  colonies) were -0.6 (-1.5%), -0.9 (-2.3%), 0.1 (0.3%) and 1.8 kg (4.8%) on the above-mentioned dates, respectively, all of which were non-significant ( $F_{4,12} = 0.190$ ,  $P = 0.940$ ).

#### ***2.3.2 Influence of restricting pollen entry to colonies (by using pollen traps) on honeybee activity***

The initial hive measurements prior to the placement of pollen traps showed no significant differences in the mean areas of stored pollen ( $F_{1,12} = 0.212$ ,  $P = 0.654$ ), mean areas of sealed brood ( $F_{1,12} = 2.171$ ,  $P = 0.166$ ), and mean hive weight ( $F_{1,12} = 0.010$ ,  $P = 0.921$ ) between the control colonies and those to which pollen traps were to be fitted.

##### ***2.3.2.1 Flight activity***

Honeybee flight activity was influenced by the use of pollen traps. A reduction in bee flight activity occurred after traps were fitted to the hive. The mean total bee flight activity of colonies with traps, 33.0 bees / 30 sec / colony, was significantly less ( $F_{1,92} = 11.581$ ,  $P = 0.001$ ) than the mean for the control colonies (i.e. those without traps), at 42.5 bees / 30 sec / colony.

The mean bee flight activity was 24.5 and 41.1 bees / 30 sec / colony in trapped colonies; and 34.6 and 55.3 bees / 30 sec / colony in control colonies, respectively, on 9 and 14 March (Figure 2.8). Results for 21 March have been previously discussed in 2.3.1.1 (i),

and are presented in Figure 2.4. The reduction in activity in colonies with traps was significant on both 9 March (-45%) ( $F_{1,87} = 15.097$ ,  $P < 0.001$ ) and 14 March (-34%) ( $F_{1,87} = 14.603$ ,  $P < 0.001$ ).

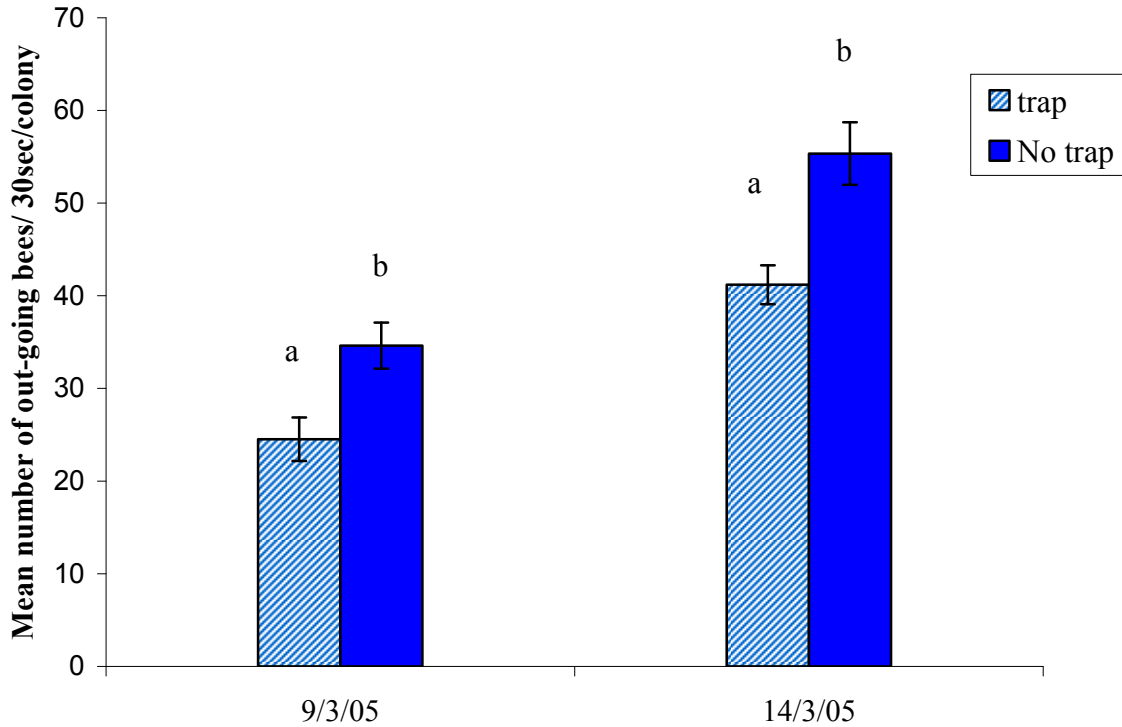

**Figure 2.8 Mean bee flight activity (number of out-going bees / 30 seconds / colony) in colonies fitted with pollen trap and control (un-trapped) colonies (n= 8) on 9 and 14 March, 2005.**

\*Data are average of counts taken each day at 08:00, 10:00, 12:00, 14:00 and 16:00.

### 2.3.2.2 *Pollen gathering activity*

#### (i) *Trapped pollen*

##### a. *Quantity of trapped pollen*

Pollen flow into colonies was estimated by weighing the amount of trapped pollen collected from all colonies fitted with traps. The total weight of incoming pollen per hive gathered by bee foragers over the 25 d investigation period, from all plant species, ranged from 660.5 g to 980.1 g (average 852.7 g), with a mean pollen income of 32.9 g / colony / d. The mean weight of approximately weekly trapped pollen was 178.1, 301.9, 275.0 and 97.7 g / colony on 11, 18, 25 and 30 March 2005, respectively (Figure 2.9); with an



average of 25.4, 43.1, 39.3 and 19.6 g / colony / d for the 11, 18, 25 and 30 March, respectively. The highest pollen yield ( $F_{3,28} = 49.744$ ,  $P < 0.001$ ) was obtained between 18-25 March 2005.

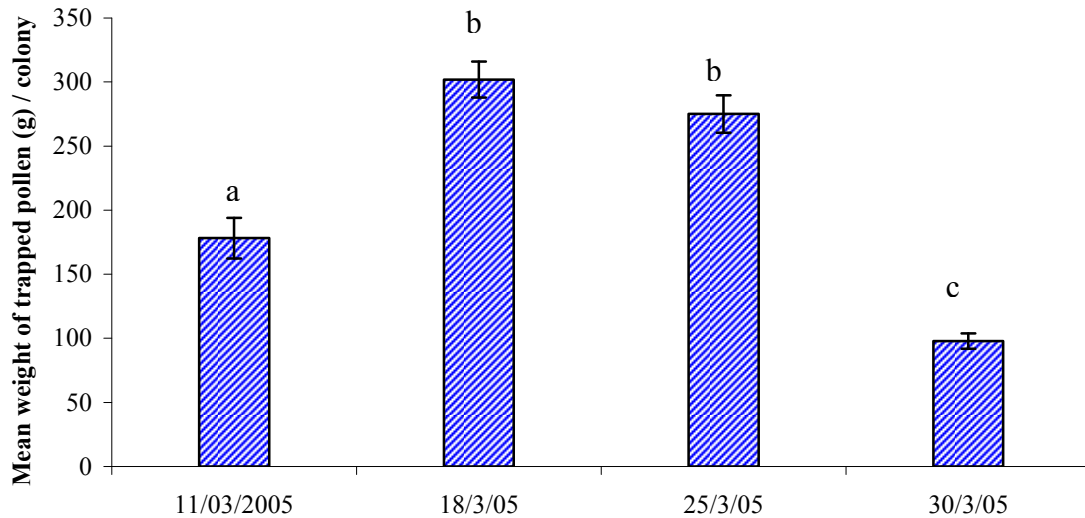

**Figure 2.9 Mean weight of trapped pollen (g) in colonies fitted with 30% efficient pollen traps (n= 8) during the investigation period 05-30/3/2005. The traps were initially fitted to colonies on 5/3/05.**

\* Bars with different letters are significantly different at  $P < 0.05$

A mean weight of 852.7 g pollen / colony was harvested over the investigation period in traps rated 30% efficient (2.2.4.1), suggesting that colonies actually gathered about 2.84 kg of pollen / colony. The total weights of incoming pollen per week for the dominant pollen source plant species are given in Table 2.1. These figures indicate a relatively heavy flow of pollen from external sources.

***b. SEM studies of trapped pollen***

Scanning Electron micrographs of pollen grains collected from corbiculae of foraging honeybees are presented in Figures 2.10 and 2.11. It is clear that there was a range of morphological differences between the grains, particularly with regard to shape, external surface structure (smooth, spiny), and size. Cotton pollen grains were, by far, the largest,

and this size difference is exemplified in Figure 2.11. Table 2.1 summarises, in relation to these pollen grains, the plant species, pollen pellet colour, average pellet weight and pollen grain size.

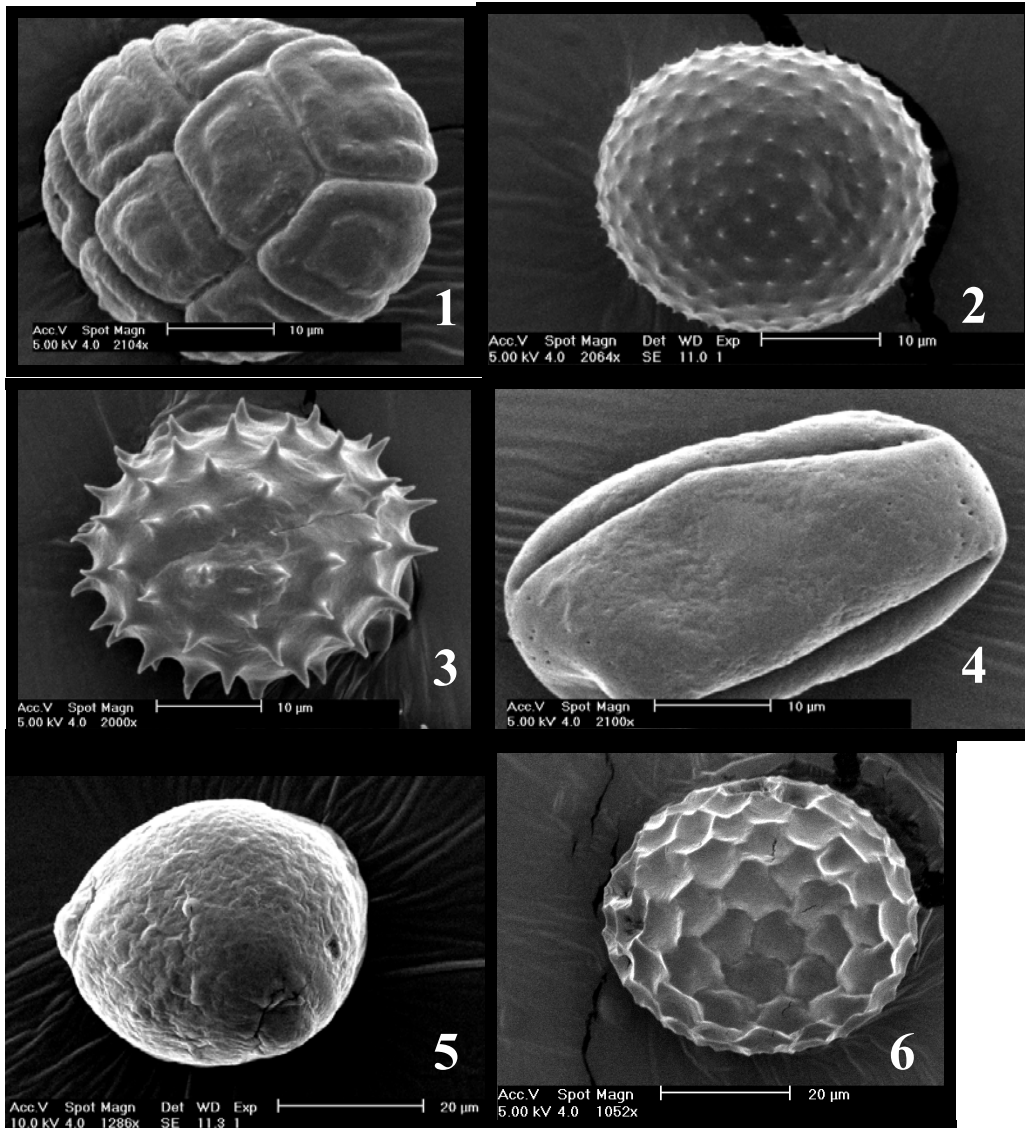

**Figure 2.10 SEM images showing the morphology of the major trapped pollen types collected from the experimental colonies, Narrabri, 2005.** (1: *Acacia concurrens* Pedley, 2: *Maireana villosa* (Lindl.) Paul G. Wilson, 3: *Helianthus annuus* L., 4: Unknown species, 5: *Melaleuca quinquenervia* (Cav.) S.F. Blake, 6: *Tribulus micro-coccus* Domin.)

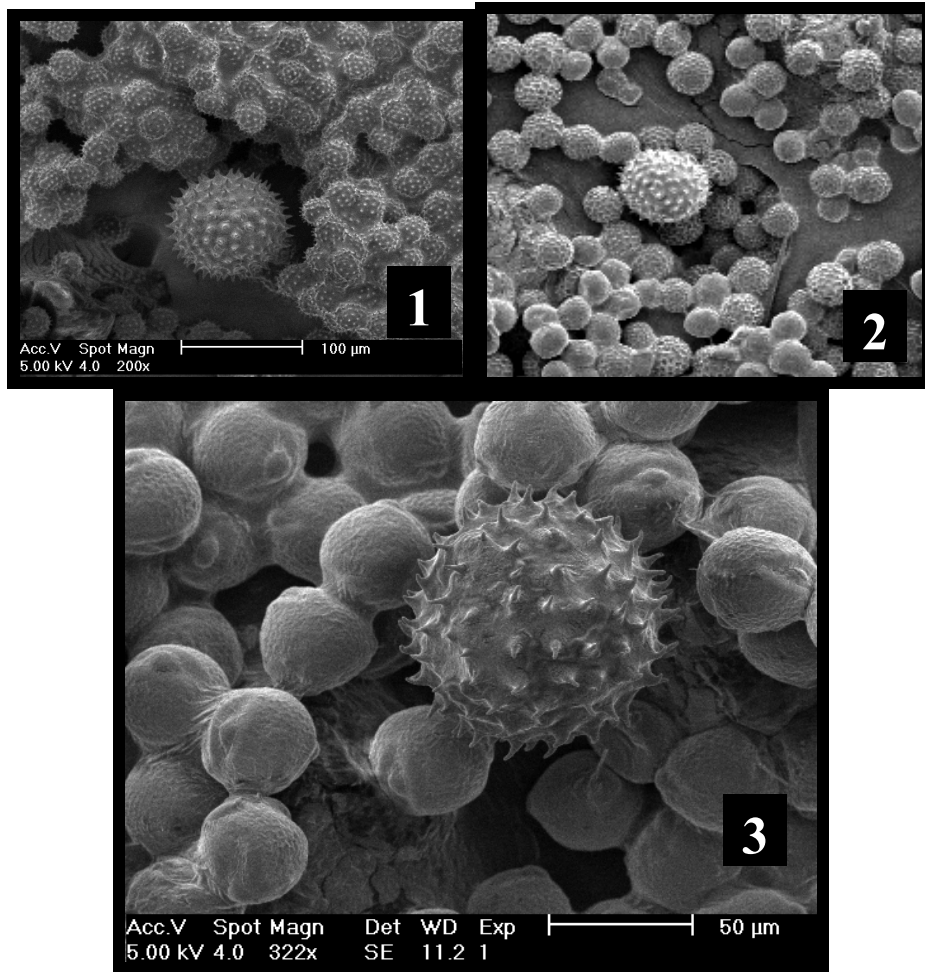

**Figure 2.11 SEM images showing the large relative size and spines of cotton pollen grain, compared to other honeybee-collected pollen.**

*c. Quantity of cotton pollen within the trapped pollen*

A random mixed sample of approximately 22,700 pollen pellets (~5,600 pollen pellets from each weekly sample) was taken from the total amount of trapped pollen of 6.8 kg for assessment as previously described. The total weights of incoming pollen / week, and total percentages for the dominant pollen source plant species are given in Table 2.1. The contribution of each source is calculated according to the weight of the total loads. The number of cotton pellets within the examined sample was 2806 (12.4%), and the average weight of 1000 pellets was the lowest (2.45 g) of all plant species and contributed only 5.3% to the total weight of trapped pollen.

**Table 2.1 The major sources of trapped pollen (g) collected by honeybees, pollen pellet colour, average weight, and size of grains.**

Plant	Pellet colour	Ave. weight of 1000 pellets (g)	Average size of grain ( $\mu\text{m}$ )	March*				Total	%
				11	18	25	30		
1 <i>Acacia concurrens</i> Pedley	Black	5.93	36	22.8	71.5	183.7	41.6	319.6	37.4
2 <i>Maireana villosa</i> (Lindl.) Paul G. Wilson	Yellow	6.42	31	67.6	61.6	15.3	4.8	149.3	17.5
3 <i>Helianthus annuus</i> L.	Orange	4.69	30	23.3	65.9	20.7	3.3	113.2	13.3
4 Unknown species	Grey	5.42	45	29.8	55.1	18.6	2.4	105.9	12.4
5 <i>Melaleuca quinquenervia</i> (Cav.) S.F. Blake	Red	5.93	40	15.9	34.6	17.2	19.5	87.2	10.2
6 <i>Tribulus micro-coccus</i> Domin.	Creamy	5.50	41	0	0	0	20.3	20.3	2.4
7 <i>Gossypium hirsutum</i> L.	Creamy- Yellow	2.45	101	15.8	10.9	15.6	2.8	45.1	5.3
8	Others	-	-	2.9	2.3	3.9	3.0	12.1	1.5
<b>Total</b>		<b>-</b>		<b>178.1</b>	<b>301.9</b>	<b>275.0</b>	<b>97.7</b>	<b>852.7</b>	

\*The traps were initially set on colonies on 5 March and the quantitative measurements were taken on 11, 18, 25 and 30 March 2005.

**(ii) Area of stored pollen**

The pre-treatment (5 March 2005) in-comb area of stored pollen averaged 289.3 and 303.6 cm<sup>2</sup> / colony for colonies to be fitted with traps and without traps (control), respectively (Figure 2.12), which was not significantly different between the two groups. Following the imposition of treatments, the mean area of stored pollen became 31.0 and 77.3 cm<sup>2</sup> / colony, and 752.4 and 286.4 cm<sup>2</sup> / colony in trapped and control colonies respectively, on 18 and 30 March 2005.

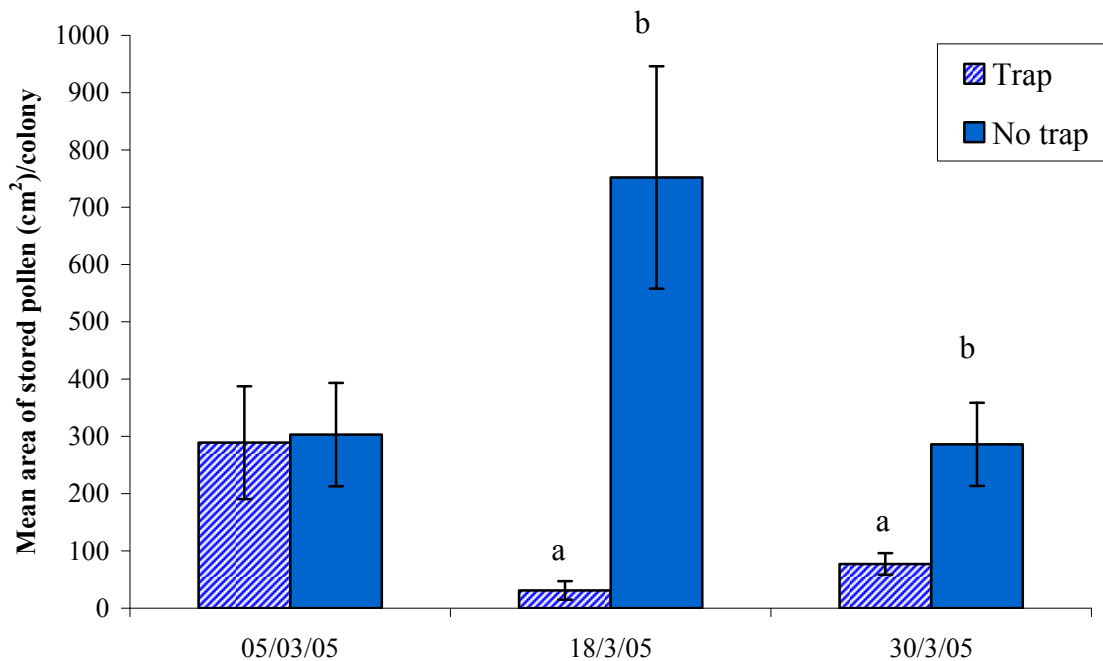
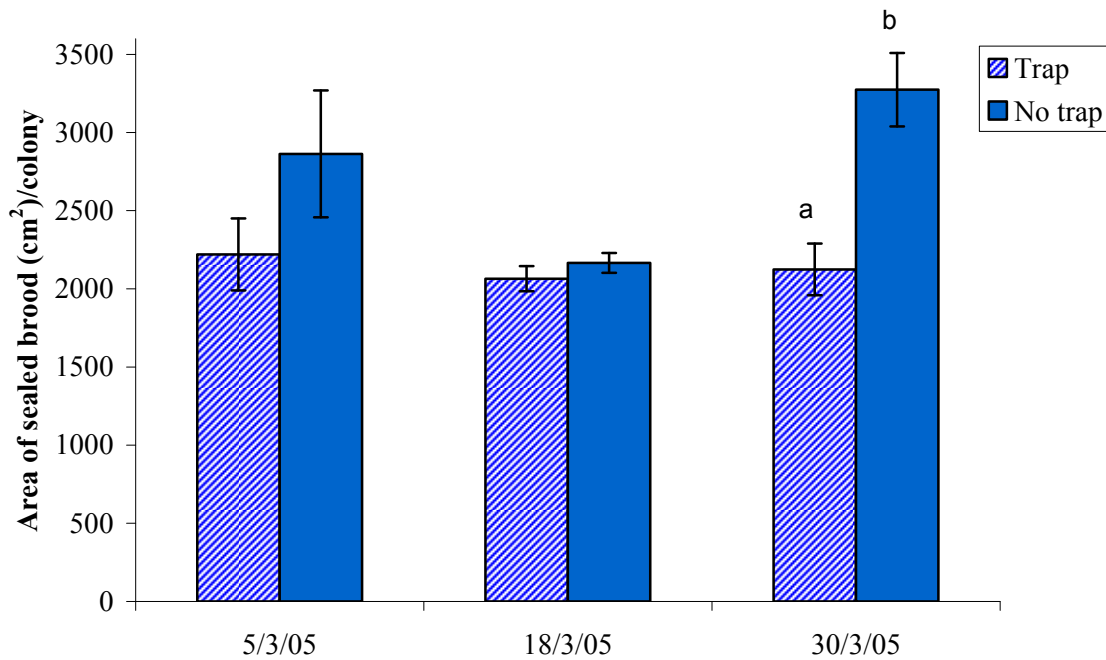

**Figure 2.12 Mean areas of stored pollen in colonies installed on 30% efficient pollen trap and control (un-trapped) colonies over the investigation period (n= 8).**

Figure 2.12 shows that a reduction in the mean area of stored pollen occurred after the traps were fitted to colonies, with these colonies having significantly less pollen than those without traps for both the first (-95.8%) ( $F_{1,12} = 19.910$ ,  $P = 0.001$ ), and second (-73%) ( $F_{1,12} = 8.177$ ,  $P = 0.014$ ) recording periods of the investigation.

### 2.3.2.3 Brood rearing activity

The pre-treatment mean area of sealed worker brood was 2219.9 and 2863.5 cm<sup>2</sup> / colony in colonies to be fitted with traps and without traps, respectively, on 5 March 2005 (Figure 2.13), which was not significantly different between the two groups. Following fitting of traps, comparative mean areas of sealed brood were 2065.6 and 2124.2 cm<sup>2</sup> / colony and 2166.1 and 3274.3 cm<sup>2</sup> / colony on 18 and 30 March 2005, respectively.



**Figure 2.13 Mean areas of sealed brood at approximately 12 day intervals in colonies fitted with 30% efficient pollen traps and control (un-trapped) colonies (n= 8).**

The data suggest that the brood rearing activity was negatively affected by fitting pollen traps. The mean sealed brood area in colonies with traps did not differ significantly in the first investigation period (-4.6%) ( $F_{1,12} = 0.928$ ,  $P = 0.354$ ). However, it was significantly less than for colonies without traps (-35.1%) ( $F_{1,12} = 22.753$ ,  $P < 0.001$ ) in the second period. The difference in area of sealed brood on 30 March between colonies with and without traps correlates with the difference in mean area of stored pollen, measured 12 d earlier, on 18 March (Figure 2.12).

### 2.3.2.4 Nectar gathering activity

The mean pre-treatment hive weight was 38.5 and 38.6 kg / colony for colonies to be fitted with traps and without traps, respectively, which was not significantly different between the two groups. However, the post-treatment hive weights (30 March 2005) averaged 35.2 and 39.1 kg / colony from colonies with traps and without traps, respectively. Thus, honey production was negatively affected by fitting pollen traps. Colonies with traps had a significantly lower (-10%) ( $F_{1,12} = 6.603$ ,  $P = 0.025$ ) weight than those without traps.

### 2.3.3 General flight activity

#### 2.3.3.1 Diurnal flight activity

The mean daily bee flight activity, assessed from the four untreated (U – T) colonies averaged over the three dates (9, 14 and 21 March 2005) at 08:00, 10:00, 12:00, 14:00, 16:00 and 18:00 were 33.6, 33.4, 35.8, 45.8, 23.4, 18.8 bees / 30 sec, respectively. Figure 2.14 shows that flight activity remained fairly constant in the morning but increased around 14:00, followed by a decrease in late afternoon-evening. However, only at 18:00 was there significantly ( $F_{5,24} = 3.410$ ,  $P = 0.024$ ) lower activity.

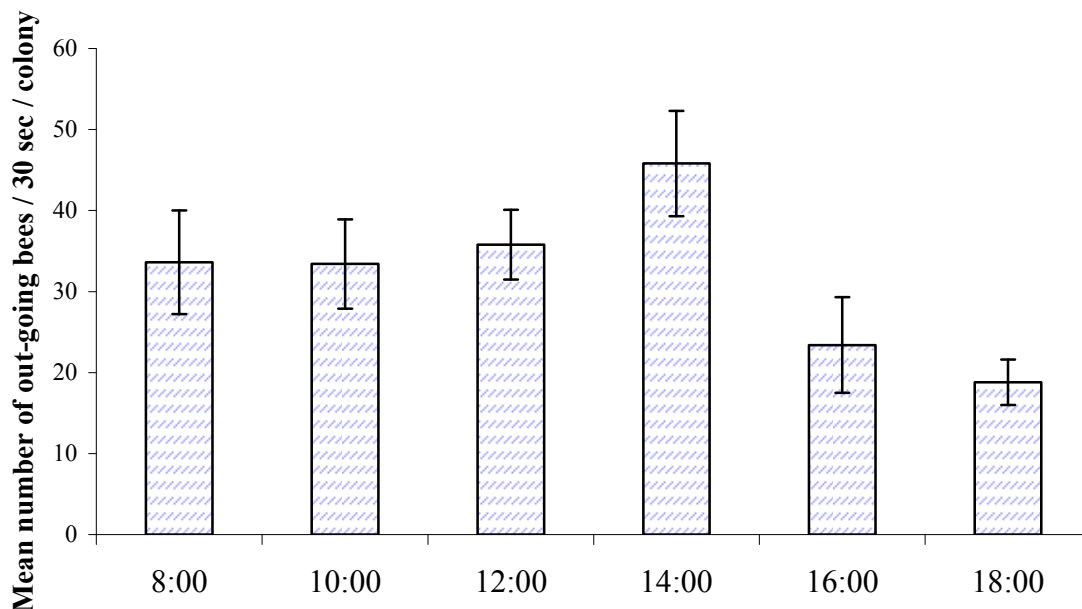

**Figure 2.14 Diurnal honeybee flight activity (mean number of out-going bees / 30 sec / colony) in untreated control colonies during the investigation period (n=4).**

\*Data are average of counts taken on 9, 14 and 21 March 2005

### ***2.3.3.2 Weekly flight activity***

The total number of out-going bees recorded from control colonies was 2314.8, with an average of 32.2 bees / 30 sec / colony. The mean flight activity was 22.6, 38.7, 35.2 bees / 30 sec / colony, respectively, on 9, 14, and 21 March 2005. There was no significant difference in flight activity between the dates.

### ***2.3.4 Bee pollination efficacy***

Pollination efficacy of honeybees in cotton was measured by relating the visitation rate of bee foragers to cotton flowers with subsequent yield parameters, including quantitative and qualitative measurements.

#### ***2.3.4.1 Foraging activity of honeybee visitors to cotton flowers***

##### ***(i) Bee foraging behaviour***

The primary observation of the foraging behaviour of honeybees visiting cotton flowers may be simply described as:

“a pollinating bee entered the cotton flower, searching for nectar at the base of the flower for 5-15 seconds; after she collected the nectar. The forager left to move to the next flower with her body clearly dusted with cotton pollen”.

A number of bee foragers were also observed on cotton leaves, scraping cotton pollen grains from their bodies before returning to their hives, apparently as a form of rejection behaviour. However, other foragers were seen actively collecting cotton pollen. These observations lead to subsequent investigations, which are discussed later in the thesis (Chapter 4).

One key observation of the foraging behaviour of honeybees was that although the cotton plants have both floral and extrafloral glands (nectaries), no bees were seen visiting the extrafloral glands on leaves or underneath flowers, although they were observed to collect nectar from the floral glands from outside the flower. As these foraging bees did not enter the flower, they were regarded as non-pollinating bees.



On the other hand, small black pollen beetles (Nitidulidae: Coleoptera), were commonly observed in cotton flowers. Although the influence of their presence on honeybee visitations was not determined in this investigation, bees were observed to fly close to some cotton flowers for more than 15-30 sec then fly away without alighting; when the flower was inspected, high numbers of pollen beetles were frequently present. These observations also lead to subsequent investigations, which are discussed in Chapter 5.

**(ii) Bee visitation rate**

A total number of 138 honeybees was recorded on cotton flowers on the three observation days during the investigation period of 25 d. Bees that collected floral nectar from outside flowers (116, 84%) were much more numerous than infloral visitors (22, 16%) (Figure 2.15), but since cotton flowers secrete little or no nectar before 10:00 (Moffett *et al.*, 1976b; Waller & Moffett, 1981) and flowers had closed by late afternoon, only the data from the 10:00, 12:00 and 14:00 observations were used in bee visitation calculations (number of bees / 100 open flowers).

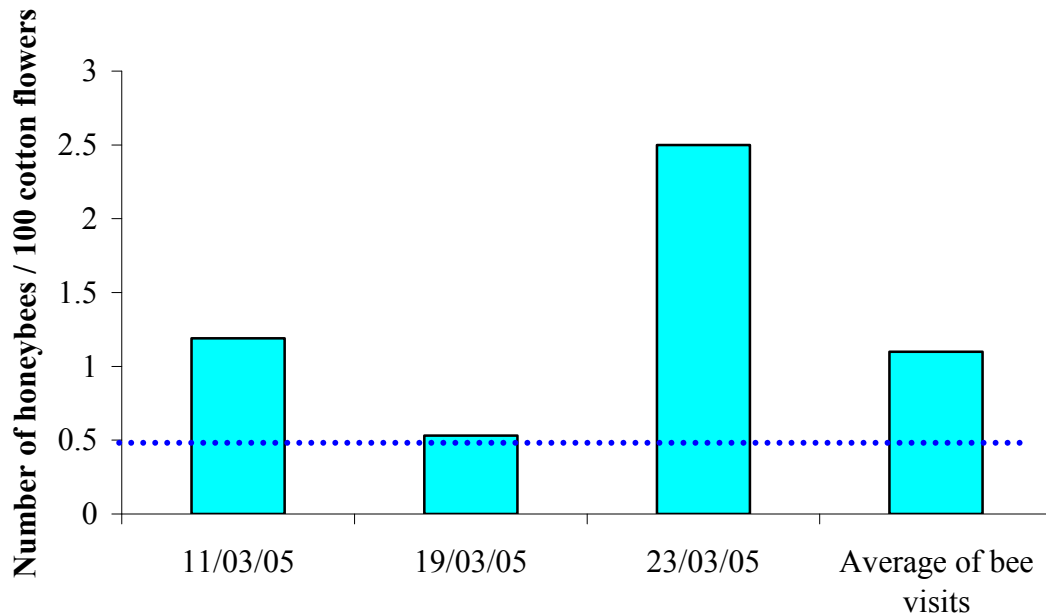

**Figure 2.15 Bee visitation rate (number of pollinating bees / 100 flowers) to cotton flowers during investigation period.**

\* Data taken at 12:00 (from 27 plots/ 15 m long)

..... 0.5% is the minimum required level for adequate bee pollination

A total of only 22 pollinating bees (i.e. pollen or floral nectar gatherers) was recorded, out of a total of 3264 flower observations, throughout the entire investigation period. At peak activity (12:00), a total of 12 pollinating bees was recorded on 1088 cotton flowers. Thus, the mean peak bee visitation rate was 1.1 bees / 100 flowers, and the temporal peak visitation rates were 1.19 (7 bees), 0.53 (2 bees), and 2.48 (3 bees) / 100 flowers, on 11, 19 and 23 March 2005, respectively.

The majority of infloral bees collected pollen. A total of 17 bees (77.3%), were observed collecting cotton pollen whereas only five collected infloral nectar.

**(iii) Diurnal bee visitation to cotton flowers**

The total number of pollinating bees observed in cotton flowers over all observations (viz. 12, 19, 23 March 2005) (Figure 2.16) was 0, 2, 12, 8, 0, 0; at 08:00, 10:00, 12:00, 14:00, 16:00 and 18:00, respectively, and this was much lower than the comparative data for the number of foraging (i.e. non-floral entrant) bees of 11, 23, 29, 23, 22 and 8, respectively. This diurnal pattern of bee visitation can be regarded as an indicator of the cotton floral food availability (nectar secretion and/or pollen release) pattern, as well as being related to the diurnal flight activity (Figure 2.14)

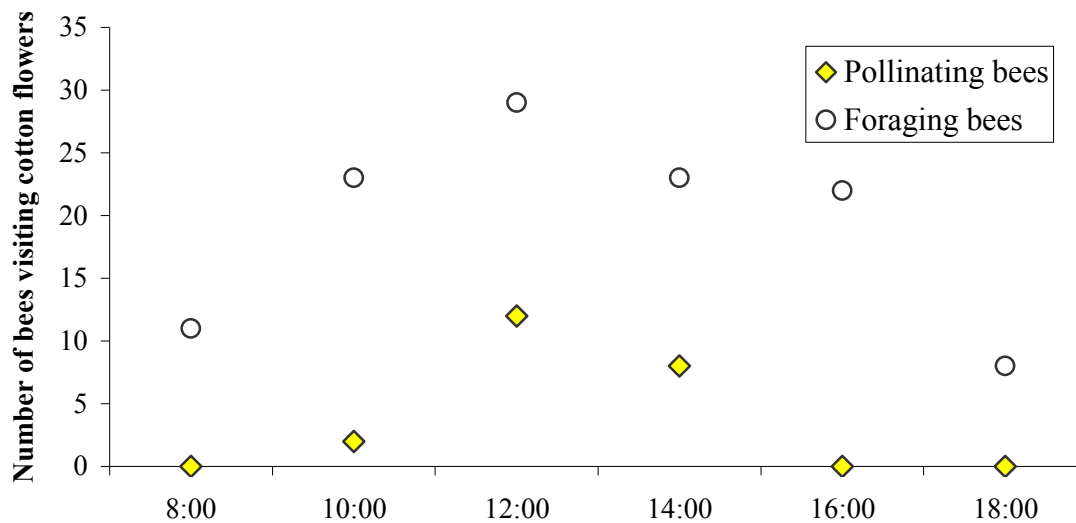

**Figure 2.16 Diurnal bee visitations to cotton flowers (total number of bees visiting cotton flowers) during the investigation period.**

Data were taken 11, 19 and 23 March 2005.

#### **2.3.4.2 *Non-Apis pollinators***

There was a low presence (13.6%) of non-*Apis* pollinators observed visiting cotton flowers, with only three individuals (1 male and 2 females) of the native solitary bee *Lithurgus (Lithurgus) rubricatus* Smith (Hymenoptera: Megachilidae) (identification: M. Batley, Australian Museum) being recorded, and all were collected on only one occasion. The female bees were observed to be actively collecting pollen, but the male appeared to be directly feeding on nectar and pollen, and remained longer in flowers (sometimes more than 2 min).

#### **2.3.4.3 *Cotton yield measurements***

Yield data were compared between caged plots and open plots (i.e. exposed to honeybees and other pollinators) (Table 2.2). Cotton in open plots had significantly higher mean boll weight ( $F_{1,6} = 7.337$ ,  $P = 0.035$ ), mean number of seeds per boll ( $F_{1,6} = 15.432$ ,  $P = 0.008$ ) and mean weight of lint per boll ( $F_{1,6} = 8.830$ ,  $P = 0.025$ ). There was a non-significant increase in the number of bolls set, and, subsequently, the total number of bolls harvested ( $F_{1,6} = 1.036$ ,  $P = 0.348$ ), total weight of bolls ( $F_{1,6} = 2.010$ ,  $P = 0.206$ ), total lint weight ( $F_{1,6} = 2.105$ ,  $P = 0.197$ ), total seed weight ( $F_{1,6} = 1.941$ ,  $P = 0.213$ ), and the total number of seeds ( $F_{1,6} = 1.897$ ,  $P = 0.218$ ) (Table 2.2).

**Table 2.2 Cotton yield parameters from cotton plants in caged and open plots at ACRI, 2005 (n=4; 2 mixed samples / replicate).**

Measurement	Cage (Mean ± SE)*	Open (Mean ± SE)*
Number of bolls / m	7.8 ± 1.2 <sup>a</sup>	10.5 ± 2.2 <sup>a</sup>
Weight of bolls (g) / m	32.4 ± 6.7 <sup>a</sup>	52.4 ± 12.3 <sup>a</sup>
Boll weight (g)	4.02 ± 0.27 <sup>a</sup>	4.89 ± 0.15 <sup>b</sup>
Number of seeds / m	211.3 ± 39.6 <sup>a</sup>	326.6 ± 73.7 <sup>a</sup>
Weight of seed (g) / m	18.6 ± 3.9 <sup>a</sup>	29.9 ± 7.1 <sup>a</sup>
Weight of 100 seeds (g)	8.69 ± 0.32 <sup>a</sup>	9.08 ± 0.18 <sup>a</sup>
Number of seeds / boll	26.4 ± 0.9 <sup>a</sup>	30.7 ± 0.4 <sup>b</sup>
Weight of lint (g) / m	13.8 ± 2.8 <sup>a</sup>	22.4 ± 5.2 <sup>a</sup>
Weight of lint (g) / boll	1.72 ± 0.11 <sup>a</sup>	2.09 ± 0.06 <sup>b</sup>

\* Means in the same row followed by the same letters did not differ significantly at P < 0.05

### 2.3.5 Flowering pattern of cotton during the investigation period

The mean daily number of freshly opened flowers / plot was 16.4, 21.7, 14.1, 4.5 and 2.5 on 4, 12, 19, 24 and 30 March 2005, respectively (Figure 2.17).

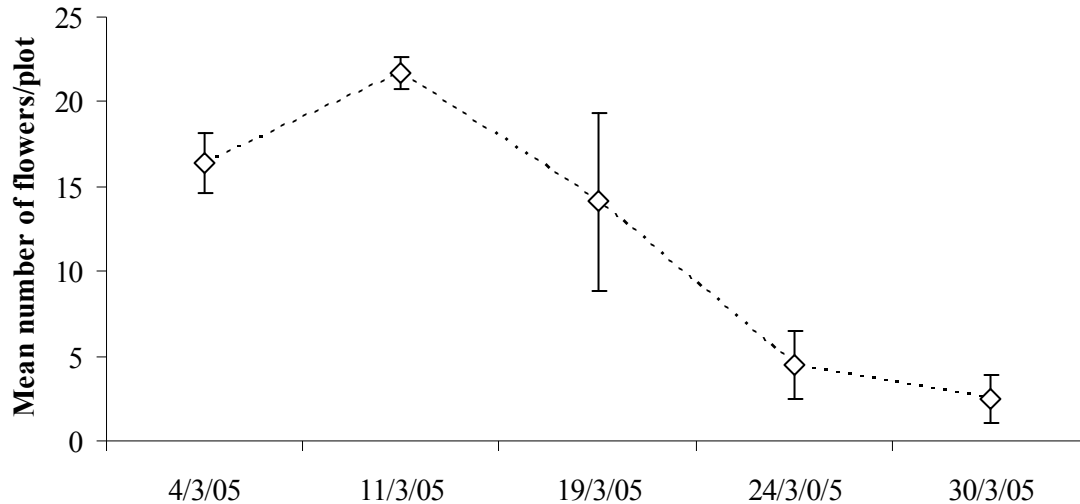

**Figure 2.17 Flowering pattern of cotton plants (mean number of flowers / 15 m plot) during the investigation period.**

### 2.3.6 *Non-cotton flowering plants*

Flowers were abundant on the investigation cotton crop; there were no other nearby cotton crops flowering, and there were no other cultivated crops near the experimental field. However, bees were observed foraging on some flowering trees and herbs (Table 2.3); it seems that these flowers were more attractive to honeybee foragers than were cotton flowers, and provided pollen and/or nectar.

**Table 2.3 Non-*Gossypium* flowering plants near the experimental field which were visited by honeybee foragers.**

Common name	Scientific name	Family
Lucerne	<i>Medicago sativa</i> L.	Fabaceae
Black wattle	<i>Acacia concurrens</i> Pedley	Fabaceae
Sunflower	<i>Helianthus annus</i> L.	Asteraceae
River oak	<i>Casuarina cunninghamiana</i> Miq.	Casuarinaceae
Tee tree	<i>Melaleuca quinquenervia</i> (Cav.) S.T. Blake	Myrtaceae
Yellow vine	<i>Tribulus micro-coccus</i> Domin.	Zygophyllinaceae

### 2.3.7 *Temperature and humidity during the experimental period*

Minimum, maximum and average temperatures and relative humidity, obtained from the data logger set at the edge of the cotton field, are shown in Figure 2.18. On a number of days, the maximum temperature exceeded 40° C. However, even on these days, the temperature at some other times was favourable for honeybee foraging, as shown by the average temperature line.

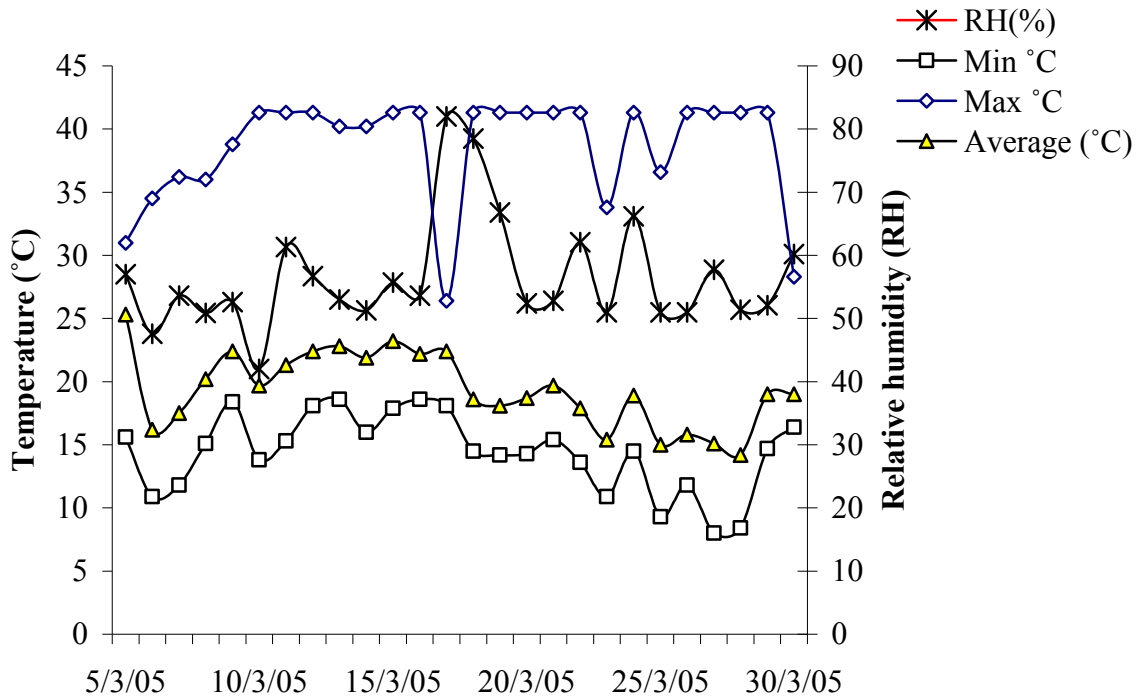

**Figure 2.18 Minimum, maximum and average temperature, and relative humidity recorded at the experimental site during investigation period (5-30 March, 2005).**

## 2.4 DISCUSSION

### 2.4.1 Influence of provision of supplementary pollen on honeybee activity

The frequency of out-going bees, under suitable environmental conditions, is likely to be a reliable indicator of the available sources of pollen and nectar in the field as well as of the colony requirements for these substances. This study showed that the total honeybee flight activity, as measured by the number of out-going bees, was higher when colonies were provided with a pollen supplement. This increase is likely to be related to the colony's demand for pollen to feed the expanding area of brood (2.3.1.3). This difference in bee flight activity in fed colonies was significant only during the first week, and coincided with more pollen being recorded in their traps than in those of unfed colonies. At the same time, nurse bees consumed the pollen patties provided, thus expanding the stored pollen area which, in turn, stimulated brood rearing activity. During the middle of the investigation period, as more pollen became available from the field, the consumption of the patties decreased. Although higher flight activity was recorded from treated colonies, it was not possible to determine their specific foraging tasks, because I did not

obtain data on in-coming bees. However, based on higher flight activity in the first week, with no increase in hive weight but with an increase in trapped pollen, it is reasonable to assume the increased activity was mainly for pollen collection.

However, supplementary feeding of colonies had no significant effect on the quantity of pollen collection (trapped pollen) by them, as nearly the same weekly quantities of pollen were trapped from fed and unfed colonies. Hence, providing pollen supplements to honeybee colonies did not reduce pollen collection from the field but increased flight activity and brood rearing. Irrespective of whether the colonies' demand was for nectar or pollen, feeding could be an effective strategy to increase honeybee pollination efficacy in cotton. This is because, based on the increased foraging activity reported in this chapter and data of foraging activity reported in Chapter 4, bees collecting nectar from within cotton flowers may play an important role in pollination. However, there is no guarantee that an increased number of out-going bees will translate to an increased number of bees in cotton flowers.

My results are consistent with those of Free & Williams (1971) and Goodwin *et al.* (1994), who stated that pollen supplements did not decrease pollen collection. This may be because bees only consume pollen supplements judiciously when there is no external pollen available (Free & Williams, 1971), which is in agreement with our findings. However, it is inconsistent with Imdorf *et al.* (1988, cited in Keller *et al.*, 2005), who reported that colonies fed with pollen supplements reduced their foraging efforts.

When considering the area of stored pollen in colonies, those provided with pollen supplements stored nearly double the quantity of pollen than unfed colonies during the first period of the study; however, this difference was not significant. Given that this was, apparently, not as a result of increased pollen gathering, it is probable that the provision of patties containing pollen and soybean flour, and not external pollen, was responsible for this increase. This is exemplified by the observation that a high consumption (100% on 11 March 2005) of the provided patty was correlated with a noticeable increase in

stored pollen during this period. However, the quantity of stored pollen decreased in the second period of the investigation, probably because of two reasons:

- (1) An increase in the amount of reared brood (requiring the pollen for food), and
- (2) A reduction in patty consumption (only 20% was consumed during the week prior to 30 March) by bee workers.

Thus, providing a pollen/soybean patty may contribute to the area of stored pollen in combs but this amount may be lower if its provision is accompanied by high brood rearing activity. My finding of increased stored pollen in fed colonies is similar to that reported by Doull (1980) and Hellmich & Rothenbuhler (1986), and for increased brood rearing by Allen & Jeffree (1956) and Al-Tikrity *et al.* (1972). Eckert *et al.* (1994) confirmed that in high brood colonies there is a significant reduction in pollen stores, indicating an increased pollen demand, and brood area may decline sharply as pollen stores are utilised (Purdie & Doull, 1964). My recording of a reduction in patty consumption with time is consistent with results reported by Purdie & Doull (1964), Free & Williams (1971), Herbert & Shimanuki (1980), and Saffari *et al.* (2004).

The observed increase in (sealed) brood area in colonies fed supplementary pollen confirms the above-stated relationship between the amount of brood and the amount of stored pollen in a colony. The pre-treatment measurements of the bee colonies showed that the amounts of stored pollen and sealed brood were similar prior to imposition of treatments. However, the increase in the area of stored pollen in colonies fed with patties, which was detected in the first period of the investigation, stimulated brood rearing activity which, in turn, resulted in a significant increase in brood production in the second period, compared with unfed colonies. This is consistent with the findings of Haydak (1945), Forster (1966, 1968), Standifer *et al.* (1971), Standifer *et al.* (1973), and Waller *et al.* (1981a) who reported that colonies fed with pollen supplements or substitutes produced more brood.



Investigations by several researchers have indicated a relationship between the amount of brood and the amount of pollen collected by a colony of honeybees. Filmer (1932) noted that foraging activity, and the proportion of pollen gatherers to nectar gatherers, increased with an increase in brood area. Several authors have established a direct relationship between the amount of pollen collected by the colony and the amount of brood in it (sealed and unsealed); (Doull, 1973, 1980) and suggested that the amount of unsealed brood might be a very effective factor in stimulating pollen collection (Allen & Jeffree, 1956; Al-Tikrity *et al.*, 1972; Free, 1967; Todd & Reed, 1970). Furthermore, Todd & Reed (1970) and Loper (1986) stated that brood measurement could be used as a valid index to the value of honeybees as pollinators. As assessment of unsealed brood is more difficult, and because sealed brood is a better indicator of larval survival and likely adult bee emergence, I assessed sealed brood. The key issue here is that this is a parameter which lags after treatment.

Although cotton has been reported as a honey source, data from the current study showed that overall, honeybee colonies did not store significant amounts of honey, presumably from any source, including cotton. This might be explained by the following:

- (1) The bee stocking rate used in these investigations was high (8 colonies / ha). Waller *et al.* (1985b) and Vaissiere (1991b) reported that honeybee colonies stocked at high rates usually store little or no honey and even dwindle, presumably because of competition.
- (2) Low nectar levels were secreted by the nearby cotton crop. The potential honey yield of upland cotton is 0-25 kg / ha, which is lower than most other crops (Crane, 1975).
- (3) Bee flight activity (number of out-going bees) was higher in mid-flowering season; however, this increase appears to be associated more with pollen flow rather than honey flow (Figures 2.9; 2.10).

In the current investigation, provision of patties did not result in more honey being stored in colonies. This can be largely explained by the fact that pollen supplements are a

protein source and so they have a direct effect on brood rearing activity rather than honey collection. My results are consistent with the findings of Goodwin *et al.* (1994) that pollen substitutes had no significant effect on honey production in kiwifruit orchards. The composition of the supplementary food to colonies, however, appears to influence honey collection, possibly because of the switch of foragers from pollen to nectar collection. Purdie & Doull (1964) found that colonies fed pure pollen produced significantly more honey than those fed three types of (non-pure pollen) supplementary patties, although Doull (1980) and Standifer *et al.* (1971) reported that pollen substitute candy patties significantly increased colony honey production, and Palmer-Jones (1947) found that colonies fed supplements produced an average of 25.9 kg more honey than unfed colonies.

#### ***2.4.2 Influence of restricting pollen entry to colonies (by use of pollen traps) on honeybee activity***

The use of pollen traps of 30% efficiency at hive entrances resulted in significantly lower bee flight activity in treated colonies during the first two weeks (40.8%, 34.5%), but flight activity was similar for the remainder of the investigation period. This is probably because the pollen traps restricted normal movement of bees, at least initially, resulting in a decrease in the number out-going bees. The similarity in bee flight activity observed in week 3 between trapped and control colonies might be due to two factors:

- (1) Foragers in these colonies learned to adapt to the traps and how to move better through the trap restrictions.
- (2) There was a general decline in bee foraging activity in all colonies, probably related to availability of external food sources.

My finding of reduced flight activity in colonies fitted with traps is consistent with that of Todd & Bishop (1940), Duff & Furgala (1986) and Goodwin & Perry (1992), who reported that traps slow the movement of foragers into and out of hives. Surprisingly, Levin & Loper (1984) stated that the number of bees leaving a colony was not affected by the presence of pollen traps, even though their study used traps with 60% efficiency

compared to the 30% efficacy traps used in the current study, and Webster *et al.* (1985) reported that bee flight activity was increased by using traps.

The speed with which the difference in flight activity between the two groups of colonies ceased in the current investigation indicates a relatively rapid adaptation by the bees to the restraint imposed by the traps. Loper *et al.* (1984) stated that most colonies do not immediately adapt to traps and the change in the entrance may cause some confusion. However, Eckert (1942) claimed that colonies are able to adjust to traps and Moriya (1966) reported that the rate of foraging returned to normal in trapped colonies after one week. Rashad & Parker (1958) and Reid (1973) suggested that pollen gatherers learn to tuck their hind legs under their bodies, allowing the pollen load to pass through the wire mesh.

Pollen collected in the traps does not represent the entire amount gathered by the colony, but it does comprise a substantial part of the harvest. Approximately 2.84 kg of pollen per colony was estimated to be harvested during the investigation period of 25 d when using traps rated at 30% efficiency, with experimental colonies collecting a mean of 32.7 g pollen / colony / d. This is equivalent to an average pollen influx of 109.0 g pollen / colony / d.

Previous figures of the amount of trapped pollen reported in the literature are not easily comparable, because of their large variation. These variations might be due to the time of the year, length of time of trapping, the trap efficiency, climatic conditions, and the availability of melliferous plant species. For example, the amounts of pollen trapped / colony have been reported to be 1.3-1.4 kg (Synge, 1947), 3 kg during the active pollen gathering season in traps rated as 10% efficient (McLellan, 1978), 3.1 kg during spring (Goodman, 1974), 10 kg between March and October (Lavie, 1967), 13.5-18 kg (Todd & Bishop, 1940), 15-29 kg (Hirschfelder, 1951) and 55.4 kg (Eckert, 1942). Unfortunately, many of these reports do not discuss either the length of time for collection or the efficiency of the traps used.

Vaissiere (1991b) using 34% efficient traps, which were similar to the 30% efficiency traps used in the current study, reported honeybee colonies collected 3.6, 6.6, 118.2 and 143.5 g pollen / colony / d in different locations. He explained the variation resulted from the great differences in floral pollen around these apiary sites. The large quantities of pollen trapped in the current investigation, compared to those reported by Vaissiere, suggests that the colonies were under good conditions for pollen collection. Interestingly, Levin & Loper (1984) found that the average efficiency of their traps increased from 33% to 60% when they were moved to different locations where different flower species were available and the foragers collected significantly larger pellets.

Pollen traps may actually motivate bee foragers to collect more pollen, by shifting from nectar-gathering to pollen-gathering once stored pollen decreases and the colonies are under stress. Lindauer (1953) for example, stated that colonies with traps had a significantly higher percentage of pollen collectors (81.5%) than did equivalent non-trapped colonies and Hirschfelder (1951), Rashad & Parker (1958), Rybakov (1961), Moriya (1966), Thorp (1979), Chambers (1980), Levin & Loper (1984) and Webster *et al.* (1985) reported similar results.

Since there was no increase in the total number of out-going bees in trapped colonies in the current study, it seems logical to assume that an increased proportion of pollen collectors may have occurred, with a corresponding decrease in nectar foragers. While this appears not to have been reflected by the number of honeybees collecting cotton pollen in the current investigation, unfortunately no data were collected at the hive entrances of the proportion of in-coming bees as pollen or nectar gatherers, to test this assumption. My assumption might be supported by Pernal & Currie (2001), who found that honeybee colonies responded to decreases in quantity or quality of pollen by increasing the proportion of pollen foragers without increasing overall foraging rate.

The amount of stored pollen in honeybee colonies is an independent component which is affected by both the rate of incoming pollen and its utilisation by honeybees. In the current study, the restriction of pollen entry into colonies together with the initial

reduction in bee foraging activity due to the presence of pollen traps reduced the mean area of stored pollen in colonies. Although at the commencement of the investigation, the mean area of stored pollen was the same for both trap and no trap groups, those with traps stored 95.8% and 73.0% less pollen than control colonies during the first and second periods of the study, respectively. These results are consistent with the findings of Levin & Loper (1984), who reported that during a four week trial, non-trapped colonies stored almost twice as much pollen as did colonies fitted with pollen traps. Apart from these colonies initially shifting more foragers to collect pollen (see above) individual foragers may also collect larger loads of pollen (Eckert, 1994). Conversely, relatively high levels of stored pollen may result in less pollen foragers (Allen & Jeffree, 1956; Fewell & Winston, 1992; Fewell & Page, 1993). Stored pollen is consumed by nurse bees that use the protein derived from the pollen to produce proteinaceous glandular secretions to feed developing larvae (Crailsheim *et al.*, 1992). Hence, brood consume pollen via nurse bees and reduce the quantities of stored pollen. If pollen is not available to a honeybee colony, brood rearing will cease (Haydak, 1970) and its population will decrease; hence colony production will decline.

The increased area of stored pollen in control colonies in the first period of the study, as previously discussed, coincided with higher general foraging activity. However, its decrease in the second period may have been because of an increase in brood production which occurred in this time, as well as a decrease in pollen collected due to a reduction in external pollen sources. In treated colonies (i.e. those fitted with traps) , the additional reduction in pollen intake, and therefore in the area of stored pollen, negatively influenced brood rearing activity and resulted in a significantly smaller area of sealed brood production, compared with control colonies.

The area of sealed brood in control colonies increased significantly only in the second period of the study, as a result of the increased area of stored pollen in the previous period. This appears to indicate that a queen laid more eggs when a greater amount of stored pollen was present in the colony, which is consistent with Cale's (1968) observation that queen oviposition is correlated with the amount of pollen collected.

During the investigation period, large amounts of pollen were consumed by all colonies for brood rearing. A critical time for colonies occurred when the demand for pollen was increasing because of brood expansion. During this period, however, the colonies with pollen traps brought in less and stored less pollen than the control colonies, and were thus unable to achieve a similar level of brood production as the control colonies.

However, while the colonies with traps stored less pollen than control colonies, it was still sufficient for them to maintain their mean area of sealed brood. Similar results were reported by Chambers (1980). This is probably because in my investigation, the traps were only 30% efficient (i.e. 70% inefficient) in removing pollen loads from incoming bees, and smaller pollen loads are not removed from the corbiculae of bees as they pass through the wire mesh of a trap.

My findings are in general agreement with a number of other investigations, although they are inconsistent with some others. For example, Levin & Loper (1984) with 60% traps, McLellan (1974) with 10% traps, and Hirschfelder (1951), Rybakov (1961), Lavie & Fresnaye (1963), Lavie (1967), Goodman (1974), McLellan (1974), and Cook (1985) all reported no noticeable effect of traps on brood rearing. On the other hand, Eckert (1942), Rashad & Parker (1958), Free (1967), Todd & Reed (1970), Ibrahim & Selim (1974), Waller *et al.* (1981a), Webster *et al.* (1985), and Duff & Furgala (1986) stated that trapping pollen negatively affected brood rearing. Unfortunately, many of these reports do not specify the efficiency of the pollen traps used, so that inconsistencies in results may be a result of this factor.

Pollen collection in the current project was closely related to availability of external food sources; hence the quantity of harvested pollen / week is a reliable indicator of the pattern of pollen availability (pollen flow) during the study period. The peak of pollen flow was recorded from 18 - 25 March 2005; this corresponded with the blooming of nearby trees and herbs (Table 2.1). Cundill (1986) suggested that major pollen and spore taxa identified from trapped pollen can provide reliable data on the dominant plant species of

the area. However, it is clear that the comparative amounts of pollen trapped may also be an indication of its relative attractiveness rather than its abundance.

Based on pellet colour and microscopic examination, the majority of pollen came from only seven plant species, with five pollens representing approximately 90% (w/w) of those trapped. Similar results were reported by McLellan (1976) where only six types represented 85% of the total amount of pollen collected.

Although honeybee foragers were observed actively collecting cotton pollen in the field, relatively little (only 5.4% w/w) cotton pollen was identified in the trapped pollen. Furthermore, the cotton pollen pellets were much looser (see Danka, 2005) and smaller (viz. two pellets weighed 4.90 g vs. 9.30 - 12.84 g) than the other pollen pellets.

Although low, my results for trapped cotton pollen are higher than those published by Waller *et al.* (1985a) who found only four pellets of cotton pollen in a total of 10,000 pellets, and Rhodes (2002) did not detect any cotton pollen. Danka (2005), however, recorded variable levels of pollen collection by honeybees from 0 - 83% cotton pollen in traps, and 18 - 44% (Waller *et al.*, 1981b), with the highest percentages collected early in the cotton flowering season (Danka, 2005).

The low percentage of cotton pollen within trapped pollen samples in the current and most other investigations may be because:

- (1) The loosely packed cotton pollen pellets might have enabled the foragers to escape with these loads through the grids of the trap. However, I did not identify stored pollen within the hive, which may have shed light on this hypothesis.
- (2) Cotton pollen was less attractive to honeybees. Foragers were observed to groom cotton pollen off their bodies before returning to their hives. This behaviour has been previously reported by McGregor (1976), Loper & Davis (1985), Moffett *et al.* (1976a), Vaissiere (1991a), Free (1993) and Rhodes (2002).

My light and electron microscope studies of the pollen collected by honeybees in the current investigation might assist in explaining why bees preferred other pollen grains to cotton. It appeared that the bees preferred to collect pollen grains which had a smooth surface; cotton pollen had much larger spines and a larger diameter than all other commonly collected pollen grains. Interestingly, while one of the commonly collected pollen grains had spines, its size was much smaller than cotton (see Figure 2.11). This appears to confirm previous hypotheses that the likely reasons for rejection of cotton pollen are because of its large size and large spines (McGregor, 1976; Loper & Davis, 1985; Free, 1993; Vaissiere & Vinson, 1994).

Honey production in colonies with traps was significantly less (approximately 10%) than in control colonies. This is similar to the results of Moriya (1966). While both groups of colonies collected noticeable amounts of nectar from cotton or/and other flowers, the lower honey production in treated colonies was likely due to two reasons:

- (1) The flight activity in colonies with traps was less, at least in the first two weeks, hence the number of nectar gatherers was lower.
- (2) The relatively large amounts of pollen trapped in mid-season showed that a considerable number of bees were collecting pollen not nectar.

Loss of pollen in the traps may have caused a re-adjustment in the activities of the foraging bees (i.e. switch from nectar collection to pollen collection: see earlier) with the result that significantly less honey was stored by the colonies with traps. Pollen traps have been reported to result in a shift in field bee activity from nectar to pollen collection that could reduce honey production (Levin & Loper, 1984).

Several workers have claimed that pollen traps have much greater impacts on colonies of honeybees than my data indicate. However, a closer inspection of their data show that some of these claims are not completely justified. Hirschfelder (1951), for example, stated that using pollen traps decreased yield of honey by 20%, basing this claim on a simple difference between the amounts of honey produced by colonies with and without



traps. Lavie (1967) claimed that pollen traps reduced the honey production of colonies by a similar percentage, but provided no data which would allow statistical verification. Rashad & Parker (1958) reported that pollen traps reduced the honey production by 41%. However, some other studies suggest that there is no effect (McLellan, 1974) or even an increase in honey yield (Rybakov, 1961).

Although, in the current study, pollen traps decreased honey production as well as the area of stored pollen and brood rearing activity, these declines appear to be mainly due to decreased flight activity, in particular in the first two weeks after the traps were fitted. The fact that the area of stored pollen was less in colonies with traps does not mean that the control colonies collected more pollen, because it was not possible to equate the amount of trapped pollen to the area of stored pollen.

### ***2.4.3 Bee pollination efficacy***

#### ***2.4.3.1 Honeybee visitation to cotton flowers***

Data on both honeybee foraging activities and cotton yield measurements were used to assess bee pollination efficacy in cotton. The mean bee visitation rate for the entire field investigation period was 1.1 bees / 100 flowers; which was higher than the 0.5% minimum level for cotton flowers for optimum pollination suggested by Moffett *et al.* (1976d).

There was a variation in the pattern of bee visitation to cotton during the flowering season. At the commencement of the study, when there were no cultivated crops or flowering non-crop plants near the cotton field and cotton flowers were abundant, the bee visitation rate reached a high level of 1.19 bees / 100 flowers. However, this decreased by more than 50% in the following week, and then increased again to ~2.5 bees / 100 flowers in the last week, despite the highest honeybee flight activity being recorded during the second week of the investigation period. This was probably the result of a fluctuation in cotton flower numbers as well as increased availability of more attractive nectar and pollen sources nearby (possible reasons for this have been previously discussed in Chapter 1 and this chapter- 2.4.2).

This was reflected by an increase in the proportion of non-cotton pollen in pollen traps at this time (2.4.2). Simultaneously, a higher number of bees were also observed foraging on nearby flowering trees and herbaceous plants; it appears that flowers of these species were more attractive than cotton flowers, and provided pollen and/or nectar. Moffett *et al.* (1980) also reported temporal fluctuations in bee visitation rates to cotton flowers, with the highest bee visits in the first week of flowering.

In the current study, diurnal bee visitation to cotton flowers was highest around midday (12:00-14:00), probably associated with the floral nectar secretion and/or water stress (temperatures commonly exceeded 40°C). This finding is consistent with that of Moffett *et al.* (1980) who found that bee visits to *G. hirsutum* flowers were highest between 10:00 and 16:00 and reached a peak of 1.65% between 13:00 - 14:00. Fewer bees were observed either early (before 10:00, 0.3%) or late (after 17:00, 0.2%) in the day and were extremely low before 09:00 and after 18:00. This is consistent with Tanda & Goyal's (1979c) report, in *G. arboretum* flowers. On the other hand, in Sudan, El-Sarrg *et al.* (1993) reported that honeybee density in cotton peaked in early morning (06:00) and afternoon (14:00 to 16:00). However, they based these findings on sweep net catches, and did not record actual numbers of bees visiting flowers or extrafloral nectaries.

The current study also showed that honeybees on the transgenic Bt cotton variety Sicot 71BR ignored extrafloral nectaries and only collected nectar from flowers. These results disagree with reports by Gourt (1955), McGregor (1976), Tanda & Goyal (1979b), Waller *et al.* (1981), and Free (1993) that honeybees prefer extrafloral nectaries in conventional cotton varieties because they have the most concentrated nectar sugars. My results are supported by Mensah (Mensah per. comm., 2007) who reported that he had not observed *A. mellifera* or other beneficial insects, which used to be numerous in conventional cotton fields, feeding at extrafloral nectaries of Bt cotton in Australia. It may be that extrafloral nectaries in Bt cotton produce less or no nectar, and this may be another reason why the trial colonies were unable store economic amounts of cotton honey. It is possible that the introduction of the Bt resistance genes into the variety may have resulted in secondary changes in plant phenotype, affecting its attractiveness or

nutritive value to bees. Such a result has been reported in oilseed rape, *Brassica napus* L. (Brassicaceae). However, in this case, the GM variety produced a significantly greater volume and more concentrated nectar compared to the conventional variety (Pham-Delegue *et al.*, 2002), even though there was no difference in bee visitation rate between the two varieties.

#### **2.4.3.2 Non- *Apis* pollinators**

It was interesting to record the presence of *L. rubricatus* in cotton flowers. They commonly forage in flowers in the family Malvaceae, many of which, such as *Hibiscus* spp. also have large pollen grains (Batley, per. comm. 2008). However, their low number and their foraging behaviour (particularly their extended time in individual flowers) suggest they probably play a minimal role in cotton pollination at Narrabri.

#### **2.4.3.3 Cotton yield measurements**

Flowering cotton plants in plots exposed to honeybees and other pollinators had significantly heavier bolls, which had higher seed numbers and lint, than did caged plots. The significantly lower boll seed numbers and lint in the caged plots were probably due to the lack of cross-pollination resulting from the absence of honeybees. This is consistent with results reported by Shishikin (1946), Kuliev (1958), McGregor *et al.* (1955), Moffett *et al.* (1978b), Vaissiere *et al.* (1984), Waller *et al.* (1985b), El-Sarrag *et al.* (1993), and Rhodes (2002).

Honeybee pollination often increases boll set (McGregor, 1976). Although I did not record this in the current investigation, there was a strong (24.9%), but non-significant, trend. Other related data (viz. weight of bolls / m, number of seeds / m, weight of lint / m) also showed the same, non-significant, trend. This may have been a result of the low number of replicates (n = 4) and the relatively lower proportion of bolls collected for yield assessments (bolls which had set before imposition of treatments, and immature bolls at the time of harvest were neglected). My results of higher weight and higher number of seeds in bolls from bee-pollinated flowers, compared with flowers caged to exclude bees, are consistent with those of Moffett *et al.* (1978b) and Tanda & Goyal

(1979a). While the lint weight / boll was higher, I was unfortunately unable to obtain lint quality data, due to a laboratory error.

Yield data, while comparative within the trial treatments, cannot be directly compared with commercial yields. This is because the experimental crop was sown late, to avoid competition with other cotton crops and associated harmful pesticide applications, and there was insufficient time for many of the bolls to mature during the season. In addition, the commencement of the trial had to be delayed for one week because of application of the pesticide fipronil in a nearby forage crop. This meant that the early flowers and bolls had to be excluded from the yield data.

The differences in yield parameters recorded in the current investigation between plots exposed to managed bees and those not exposed to bees compares favourably with that reported for cotton in Australia by Rhodes (2002). However, my bee stocking rate was 8 colonies / ha compared with < 1 colony / ha, and my comparative treatments were plants caged without bees and uncaged plants exposed to potential pollinators, whereas Rhodes compared different bee visitation rates to uncaged plants.

It should also be noted that the hives used in these investigations were not typical of normally managed colonies. They were subjected to other studies, which involved imposition of different feeding regimes, and disruptive inspections of all hive frames to assess areas of stored pollen and sealed brood.

One always has to be careful about interpreting data from caged experiments, as shading by the experimental cages may have some influence in reducing photosynthesis and depleting the resources needed for flower and fruit development (Snelgar & Hopkink, 1988). Inevitably, cage influences the light intensity, temperature, humidity and wind speed to which the plants inside are subjected; but the extent to which it does so varies with different climatic conditions, different types of cages and the plant species concerned. (Free, 1993). A cage designed by Pedersen *et al.* (1950) had little effect on the environment to which plants were subjected, compared to cages of an earlier design with

walls of metal screen or cloth (Wafa & Ibrahim, 1960a). The relative humidity, light and wind speed inside were slightly reduced, but the temperature remained the same. However, cotton plants have been reported to reduce their growth, development and yield under low light intensity (Kearney, 1924; Knight, 1935; Eaton & Ergle, 1953; Meyer, 1969). Moffett *et al.* (1972b) reported that cage screens affected cotton plants adversely, reducing flower production by up to 50%. When light intensity was decreased from 73% to 53% yield was reduced by 50%. Zhao & Oosterhuis (1988) reported 45-55% decrease in leaf photosynthesis when plants were subject to an 8 d period of shade (with 63% reduction in light intensity).

The materials used in the studies reported in this thesis and the relatively short duration used (25 d) should have minimized cage effects. In the current study, the light intensity (photosynthetic photon flux density), measured with a light meter (COR LI-250, LI-COR BioSciences, Lincoln, NE, USA) at the top of the crop canopy at 11:00 (EADST) on four separate days during the investigation period, was between 1650-1750  $\mu\text{mol} / \text{m}^2 / \text{s}$  in cages, compared to 2035-2100  $\mu\text{mol} / \text{m}^2 / \text{s}$  under uncaged conditions. This is a reduction in light intensity to 81.1-83.7% of that normally experienced at Narrabri during the peak cotton season, a substantially higher light intensity than that reported by Moffett *et al.* (1972) and Zhao & Oosterhuis (1988) that caused yield reduction in cotton. These cages are commonly used by the cotton plant breeders at the Australian Cotton Research Institute, with no apparent impact on plant physiology or reduction in yield. In addition, the cages were only used for a period of 25 d and dismantled immediately after the investigations. Subsequent trials reduced the time of coverage (Chapter 4).

## **2.5 CONCLUSIONS**

- Feeding supplementary pollen/soybean flour as a patty to colonies increased bee flight activity and brood production. It did not reduce pollen collection. So it appears to be advantageous to feed colonies supplementary pollen to optimize pollination in cotton, especially as nectar gatherers are also likely to contribute to pollination.

- Although the installation of pollen traps reduced the ability of bee colonies to store pollen the data show that, at least for a short time, colonies with traps could be successfully used in pollination. However, for longer periods traps are likely to cause a decrease in brood production and, thus, in the population of colonies.
- Cotton flowers and cotton pollen were not highly attractive to honeybees. Although pollen traps and the provision of supplementary pollen may stimulate colony pollen collection, more work is needed to ensure that any increased field bee activity is directed towards cotton flowers. One way to achieve this is the use of bee attractant products such as queen mandibular pheromone. This product has not been used in cotton fields previously, so an investigation was conducted as part of my PhD studies (Chapter 3).
- This study showed that honeybees can cross-pollinate cotton plants and increase the cotton boll size, seed number and lint yield. I suggest that managed honeybees may play a useful role in increasing cotton yields. This, however, can only be achieved when cotton growers adopt IPM programs that are environmentally friendly to non-target arthropods such as honeybees (see Chapters 4, 6).
- While the effect of some other species of beetles in flowers of other crops has been published, nothing has been reported for pollen beetles in cotton, although Rhodes (2002) observed these insects in Australian cotton fields. Thus, the role pollen beetles play in cotton flower pollination and their effect on the behaviour of honeybees on cotton flowers is still unknown. Studies to investigate these two aspects were also conducted as part of my PhD studies, and are described in Chapter 5.

## CHAPTER 3

### THE EFFECT OF SYNTHETIC QUEEN MANDIBULAR PHERMONE ON HONEYBEE FORAGING ACTIVITY IN COTTON FLOWERS, AND SUBSEQUENT EFFECTS ON YIELD AND QUALITY

#### 3.1 INTRODUCTION

Honeybee pollination is often closely associated with increased fruit, vegetable, seed yield and quality. Consequently, crop pollination is big business in many countries, with migratory beekeepers transporting their colonies from one crop to another. More than 500,00 hives are used annually for honey production and pollination in Australia (Wills, 1989), particularly in almonds, apples, canola, cherries, clovers, melons, pumpkins, pears, onions, kiwi fruit, lucerne, sunflowers, cotton, and macadamia nuts (Anon, 2007b).

Although large numbers of bee colonies are used for pollination, some crops may still experience inadequate pollination, even in the presence of honeybees, because of unattractive flowers, unfavourable weather conditions for honeybee flight during pollination period, or competition from more attractive plant species nearby (McGregor, 1976; Robinson *et al.*, 1989; Free, 1993), resulting in reduced yields, occasional crop failures, and lowered crop quality.

Although cotton is primarily a self-pollinated crop, cotton flowers visited by honeybee foragers have been reported to produce heavier bolls with improved lint quality. This has been discussed elsewhere in this thesis. The rental of hives for Australian cotton pollination is lower (\$A 45 per hive for the cotton flowering season) than for other crops such as onions (\$A 88), kiwi fruit (\$A 80), melons and pumpkins (Cucurbitaceae) (\$A 77), canola, sunflower, and lucerne (\$A 55) (Anon, 2007b). Furthermore, extensive use of insecticide sprays on cotton during the flowering season can kill bees and contaminate honey. As a consequence, most Australian beekeepers avoid locating their hives near cotton fields (Stace, 1994).

Boll weight and lint quality are important components of the final value of a cotton crop. Sometimes saturation with bee colonies is required to achieve optimal production (Grout, 1955); as cotton still may not receive adequate cross-pollination using similar stocking rates as for other crops (McGregor, 1976; Moffett *et al.*, 1980). Some factors that may be responsible for this inadequate bee pollination have been previously discussed (Chapter 1).

The major challenge in pollination management is how to attract bees to target crops and away from more attractive, competing blooms (Free, 1968c). The attraction of bees from a competing pollen source to the target crop is essential to maximise cross-pollination. Various materials have been tested as honeybee attractants, some of which have shown promise. These attractants include sugar syrup (Free, 1965), citral and geraniol, (Waller, 1970; Woyke, 1981).

A number of commercial products based on sugar syrup (e.g. BeeLure, Bee-Q, Beeline®) have been used, with mixed success (Burgett & Fisher, 1979; Belletti & Zani, 1981; Rajotte & Fell, 1982; Margalith *et al.*, 1984; Ambrose *et al.*, 1995; Singh & Sinha, 1997). Other products based on worker-bee nasov gland pheromone (e.g. BeeHere™, and BeeScent) have showed some promising results (Butts, 1991; Neira *et al.*, 1997) (see Chapter 1).

The other pheromone product is queen mandibular pheromone (QMP), which is produced from the mandibular glands of mated honeybee queens, and has been identified as a five-component pheromone blend consisting of 250 µg 9-keto-2(E)-decenoic acid, 150 µg 9-hydroxy-2(E)-decenoic acid (66% R(-)), 20 µg methyl *p*-hydroxybenzoate and 2 µg 4-hydroxy-3-methoxyphenylethanol (Slessor *et al.*, 1988, 1990). QMP has been shown to be highly attractive to worker bees even at extremely low concentrations. One queen equivalent (QE) is used as the measure of its concentration for application; this is defined as the amount of pheromone in an average pair of queen mandibular glands (Slessor *et al.*, 1988).



Synthetic QMP can be used in swarm control, in disposable pollination units and for transportation of honeybee packages, but its major application seems to be for pollination enhancement (Winston & Slessor, 1993). Fruit Boost<sup>®</sup> has been reported to increase bee activity and yield of many crops such as cranberry (Currie *et al.*, 1992b; Mackenzie & Averill, 1992), blueberry (Currie *et al.*, 1992b), pear (Currie *et al.*, 1992a). While increased foraging activity occurs in pheromone-sprayed blocks, this effect has been reported to last for only 1-2 days after application (Currie *et al.*, 1992). Some researchers have provided economic benefits; for example, Currie *et al.* (1992b) reported a profit of \$US 8804 and \$US 986 / ha from cranberry and blueberry, respectively, after QMP application, and \$US 1055 / ha in pears (Currie *et al.*, 1992a). Also, increased returns of \$US 400 / ha in (Anjou) pears were reported from the application of QMP, without any significant increase in bee activity or fruit set compared with untreated plots, on the basis of increased fruit size (Naumann *et al.*, 1994).

However, the failure of QMP to increase yields has been reported in several crops, including apricots (McLaren *et al.*, 1992), apple (Currie *et al.*, 1992a), cranberries (Currie *et al.*, 1992b; Mackenzie & Averill, 1992), sweet cherry (Naumann *et al.*, 1994) and kiwifruit (Howpage, 1999).

Because of the value of cotton to the Australian agricultural economy and the fact that no work has been published on the use of bee attractants in cotton, this chapter presents outcomes from observations and experiments conducted to find more definitive answers on:

- (1) The effect of one potentially attractive spray, synthetic QMP (Fruit Boost<sup>®</sup>), on attracting foraging honeybees into cotton flowers (i.e. increasing bee visitation), and
- (2) The effect of QMP on cotton boll set, as well as on other qualitative and quantitative yield parameters.

## **3.2 MATERIALS AND METHODS**

### **3.2.1 Location**

This study was conducted in a 9 ha private commercial transgenic Bt (Bollgard<sup>®</sup> II) cotton field at Narrabri in north-west NSW. The crop was subjected to normal agricultural practices, although no pesticides were applied immediately prior to, nor during, the investigation period. To facilitate movement of the equipment for application of QMP treatments, no irrigation was applied to the field from two days prior to commencement of the trial until its completion.

On 30 January 2006, six strong double chamber Langstroth hives with honeybees were transported to the experimental site. At this time, most of the cotton plants were at peak flowering. All colonies were placed at the north edge of the field, with no shading provided, and remained there until they were removed on 5 February 2006.

### **3.2.2 Treatments**

Three treatments were used to evaluate the effect of synthetic QMP (Fruit Boost<sup>®</sup>, PheroTech Inc., Delta, BC, Canada) on bee visits and cotton yield. Two concentrations of QMP were applied to the experimental plots and these were compared with control plots, which were sprayed with water only, the carrier of QMP. The treatments were therefore

- (i) QMP 50 QEQ / ha
- (ii) QMP 500 QEQ / ha
- (iii) Water sprayed control

In total, nine, 0.1 ha plots were established in the trial field, in a late planted cotton crop, in a completely randomised block design (RCBD) with three replicates for each treatment: one at each of distances of 100, 200 and 300 m from the bee hives. The three treatment plots in each line were separated from each other by a 60 m buffer zone. This was done to provide foragers the opportunity to clearly distinguish between treated plots, and also to allow for any spray drift between treatments. Each plot was rectangular, with dimensions

of 43 m length, and 24 rows (1 m apart) wide, to optimise the efficacy of the experimental product.

On 1 February 2006, Fruit Boost<sup>®</sup>, when the crop was in peak bloom, was applied to the cotton foliage and flowers in the treatment plots, using a tractor-mounted ground sprayer. The rate of 125 mL product / 500 L water / ha (the maximum volume of fluid which could be applied to cotton by a ground sprayer) was applied at the rate of 50 L of solution per plot, which was sufficient to wet flowers and foliage. The mixtures were prepared in the spray tank after it had been cleaned and well rinsed with water. It was not practical to mix individual batches of spray for each replicate, as we were using equipment provided by ACRI, 20 km distant, and the applications were required to be made between sunrise and 09:00, prior to the time when bees became most active. For the control plots, only water (the carrier of QMP), was applied, at the same rate as in the treatment plots (viz. 50 L / plot). The control was applied prior to the application of the QMP treatments, to prevent any contamination with the QMP residues that may have remained in the tank. Treatment applications were commenced at 06:00 and were completed by 09:00. The same treatment applications were repeated on 3 February 2006.

The parameters used to assess the effectiveness of QMP were: bee activity, percent boll set, lint and seed yield, and lint quality.

### ***3.2.3 Assessment of bee activity***

Honeybee activity was determined by selecting four rows 43 m long (Rows 8, 9, 16, and 17) within each treatment plot for data measurements, and the row data were averaged to give a value for the plot. Data were taken at 12:00 and 14:00 (to coincide with maximum bee activity) on the day of spray application and the following day, by counting the number of honeybees on cotton flowers (McGregor, 1976). Bee activity was measured by recording bee visits on all flowers in the row. This methodology is described in detail in Chapter 2.2.3.1. Each infloral bee visit was scored as a pollinating bee, whereas visits to extrafloral nectaries or to collect floral nectar from outside the flowers were regarded as

‘non-pollinating bees’. Results were expressed as the mean number of pollinating honeybees / 100 flowers.

#### ***3.2.4 Percentage boll set***

Fruit set is commonly used as an indicator of pollination success, and this was measured as the percentage of flowers that produced bolls. A total of 50 flowers were randomly selected from the middle row (Row 12) of each experimental plot, on the day of application and the day following application, for each of the two sprays. All selected flowers were tagged, with different colours used for flowers for each of the two sprays, to enable easy identification for subsequent boll counts.

Fruit set was determined by counting the number of the tagged flowers that set bolls, and dividing by three (viz. dividing by the total number of tagged flowers / treatment / application [300], then expressing as a percentage).

#### ***3.2.5 Assessment of cotton yield***

The effect of the treatments on subsequent cotton yield parameters was determined by hand harvesting of the fully mature bolls from the tagged flowers in all plots. Bolls were harvested on 16 April 2006 and were retained separately according to the replicate plot, the treatment and the date their flowers were tagged. They were placed into bags and processed at ACRI, for quantitative measurements and qualitative tests (these methodologies are described in detail in Chapter 2.2.7.2).

##### ***I. Quantitative measurements***

Cotton samples were debarred, ginned (cotton seeds separated from the lint) and evaluated for eight parameters: number of bolls, weight of bolls, weight of lint, seed weight, number of seeds per sample, weight of 100 seeds, number of seeds per boll, and weight of lint per boll.

## ***II. Qualitative measurements***

After ginning, the lint from each plot was mixed by hand to gain a representative sample. Samples (30 g) of cotton lint were then taken from the mixed lint, on the basis of one sample from each of the plots. Each sample was subjected to four standard cotton lint quality measurements: length, uniformity, strength and micronaire.

### ***3.2.6 Recording meteorological conditions during the investigation period***

As temperature and humidity are the major climatic factors that influence both honeybee activity and cotton plant physiology (see Chapter 2.2.10), these data were collected at the field site from 31 January to 5 February 2006.

### ***3.2.7 Data analysis***

Data for mean bee visitation, yield quantity and quality were compared between treatments using mixed model of analysis of variance (ANOVA) SPSS® for Windows™ Version 14 (SPSS Inc. 2007), with two fixed factors: treatment (QMP) and time of assessment, and a random factor, block. The relationship between the number of bees visiting flowers and the number of bolls set was explored using Pearson correlation (Pearson, 1896). The values are normally presented as mean  $\pm$  standard error (SE) of the mean.

## ***3.3 RESULTS***

### ***3.3.1 Assessment of bee activity***

A summary of the results of honeybee activity, the day of and the day after the two applications of Fruit Boost®, is presented in Table 3.1.

QMP when sprayed at 50 QEQ and 500 QEQ / ha did not significantly ( $F_{2, 12} = 0.484$ ,  $P = 0.628$ ) affect foraging of honeybees under the experimental conditions, compared to the water only control. The mean (pollinating and non-pollinating bee) flower visitation rate to treated plots, combining the two applications of sprays, was 0.57, 0.49, and 0.45 bees / 100 flowers on 50 QEQ, 500 QEQ and control plots, respectively (Table 3.1).

The mean visitation rate (i.e. the honeybee foraging activity) in the treated plots was higher on the day of application (0.92 and 0.42 bees / 100 flowers) compared with the day after application (0.53 and 0.16 bees / 100 flowers) (Table 3.1). There were significant differences in flower visitation between assessment days ( $F_{3,12} = 9.382$ ,  $P = 0.002$ ). Ryan's Q-test shows that flower visitation was significantly higher on the first assessment day, with no differences between the other three sampling days. There was no interaction between treatments and date of application ( $F_{6,12} = 0.171$ ,  $P = 0.383$ ). Hence, there were no significant differences in mean total or daily bee activity ( $F_{2,12} = 0.484$ ,  $P = 0.628$ ) between any of the QMP or control treatments.

**Table 3.1 Effect of application of different doses of synthetic queen mandibular gland pheromone Fruit Boost<sup>®</sup> on honeybee foraging activity\* on cotton flowers\*\*.**

Measurement*	Treatment			Mean $\pm$ SE*** (across all plots)
	50 QEQ	500 QEQ	Control	
<b>Application 1</b>				
01 Feb 06	0.85	0.91	1.05	0.92 $\pm$ 0.08 <sup>a</sup>
02 Feb 06	0.82	0.20	0.20	0.53 $\pm$ 0.15 <sup>b</sup>
<b>Application 2</b>				
03 Feb 06	0.5	0.42	0.42	0.42 $\pm$ 0.07 <sup>b</sup>
04 Feb 06	0.10	0.23	0.42	0.16 $\pm$ 0.07 <sup>b</sup>
<b>Mean <math>\pm</math> SE***</b>	0.57 $\pm$ 0.12 <sup>a</sup>	0.49 $\pm$ 0.13 <sup>a</sup>	0.45 $\pm$ 0.13 <sup>a</sup>	

\* Number of bees per 100 flowers (data were taken at 12:00 and 14:00).

\*\* Combined pollinating and non-pollinating bees

\*\*\* Means in columns or rows followed by the same letter are not significantly different at  $P < 0.05$  (Ryan's Q-test).

The total number of cotton flowers observed in the experiment was 22052, and a total of 109 bees were recorded visiting these flowers. Twenty-five (22.9%) of these bees were infloral foragers (viz. pollinating bees), while 84 bees (77.1%) collected floral nectar from outside the flowers (non-pollinating bees). Totals of 41, 34, 34 floral visiting bees were recorded on the 50 QEQ, 500 QEQ and control plots, respectively (Table 3.2). The

pollinating honeybee (i.e. 25 bees / 22052 flowers) visitation rate was calculated to be 0.11 bees per 100 flowers, which is lower than the optimum rate of 0.5 reported by Moffett *et al.* (1976c) and lower than that reported without pheromone use in Chapter 2.

**Table 3.2 Proportion of pollinating and non-pollinating honeybees visiting cotton flowers treated with different doses of Fruit Boost®.**

Measurement*	Treatment			
	50 QEQ	500 QEQ	Control	Total
<b>Application 1</b>				
Pollinating bees (P)	7	2	6	15
Non-pollinating bees (NP)	18	18	15	51
<b>Application 2</b>				
Pollinating bees (P)	4	3	3	10
Non-pollinating bees (NP)	12	11	10	33
Total P: NP	11:30	5:29	9:25	25:84

\* Number of bees per treatment (combined data of 1<sup>st</sup> and 2<sup>nd</sup> day of application, data were taken at 12:00 and 14:00).

### 3.3.2 Percentage boll set

The percentage boll set, based on assessments of 600 tagged flowers per treatment, were 30.5%, 38.8% and 38.8% in 50 QEQ, 500 QEQ and control treatments, respectively. Although all treatments in Application 1 had greater bee activity and number of matured bolls than for Application 2, these were not statistically significant. Neither concentration of QMP resulted in significantly increased fruit set, yield, or lint quality parameters compared to the water-only control (Table 3.3).

The number of bolls set (and % boll set) from 300 tagged flowers was 107 (35.6%), 155 (51.6%), and 166 (55.3%), in the 50 QEQ, 500 QEQ and control plots respectively, following the first spray application, with a mean boll set across all treatments of 47.5% (Table 3.3). Flowers exposed to the second application had lower boll set of 76 (25.3%), 78 (26%), and 67 (22.3%) in the 50 QEQ, 500 QEQ and control plots, respectively, with

mean fruit set across all treatments of 24.5% (Table 3.3). No significant differences were found between treatments in relation to either bee visitation rate ( $F_{2,12} = 0.484$ ,  $P = 0.628$ ) or cotton yield ( $F_{2,6} = 0.518$ ,  $P = 0.620$ ). Also, Pearson correlation showed there was no significant relationship between bee visitation rate and number of bolls set ( $r = 0.306$ ,  $P = 0.217$ ).

**Table 3.3 Pollinating (infloral) honeybee visitation to cotton flowers and subsequent boll set, following applications of different doses of Fruit Boost<sup>®</sup>.**

Measurement	Treatment			
	50 QEQ	500 QEQ	Control	Total
<b>Bee visitation*</b>				
Application 1	0.24	0.07	0.18	<b>0.17</b>
Application 2	0.08	0.08	0.07	<b>0.08</b>
<b>Boll set**</b>				
Application 1	107 (35.6%)	155 (51.6%)	166 (55.3%)	<b>47.5%</b>
Application 2	76 (25.3%)	78 (26%)	67 (22.3%)	<b>24.5%</b>
<b>Total</b>	<b>183 (35.5%)</b>	<b>233 (38.8%)</b>	<b>233 (38.8%)</b>	<b>36.0%</b>

\* Mean number of pollinating bees per 100 flowers (combined from day of application and the following day at 12:00 and 14:00 observations).

\*\* Total number of bolls set (and %) / 300 tagged flowers / application.

### 3.3.3 Assessment of cotton yield quality and quantity

From the 600 tagged flowers (i.e. combining results from both applications), 183, 233 and 233 set bolls after application of QMP at 50 and 500 QEQ and in the control, respectively, however these numbers were not significantly different ( $F_{2,6} = 0.585$ ,  $P = 0.586$ ) from each other. There were also no significant differences between any other parameters measured, including total weight of bolls ( $F_{2,6} = 0.518$ ,  $P = 0.620$ ), average boll weight ( $F_{2,6} = 0.656$ ,  $P = 0.553$ ), number of seeds / sample ( $F_{2,6} = 0.481$ ,  $P = 0.640$ ), average weight of seeds ( $F_{2,6} = 0.501$ ,  $P = 0.629$ ), number of seeds / boll ( $F_{2,6} = 0.069$ ,  $P = 0.934$ ), weight of lint ( $F_{2,6} = 0.544$ ,  $P = 0.607$ ), and weight of lint / boll ( $F_{2,6} = 0.403$ ,  $P$



= 0.685) (Table 3.4). However, the trend towards higher boll set in the 500 QEQ and control plots, resulted in similar trends for the total mean weight of bolls, mean weight of seeds and mean weight of lint in these treatments.

**Table 3.4 Effect of application of different doses of synthetic queen mandibular gland pheromone Fruit Boost<sup>®</sup> on cotton yield parameters.**

Measurement	Treatment (Mean ± SE)*		
	50 QEQ	500 QEQ	Control
Number of bolls / plot	61.0 ± 12.0	77.6 ± 17.5	77.6 ± 4.6
Weight of bolls (g) / plot	327 ± 62	432 ± 108	399 ± 36
Boll weight (g)	5.3 ± 0.1	5.4 ± 0.2	5.1 ± 0.2
Number of seeds / plot	1736 ± 348	2250 ± 564	2181 ± 215
Weight of seed (g) / plot	196.9 ± 37.8	259.6 ± 64.7	237.8 ± 21.0
Weight of 100 seed (g) / plot	11.3 ± 0.2	11.5 ± 0.3	10.9 ± 0.3
Number of seeds / boll	28.4 ± 1.1	28.5 ± 0.9	27.9 ± 1.2
Weight of lint (g) / plot	129.7 ± 24.4	172.93 ± 43.8	161.0 ± 14.8
Weight of lint (g) / boll	2.13 ± 0.07	2.18 ± 0.08	2.07 ± 0.10

\*All values of measurements in the same row did not differ significantly at  $P < 0.05$ .

A comparison of lint quality data between the two QMP treatments and water only control showed that there were no significant differences between any parameter measured (Table 3.5); lint length ( $F_{2,6} = 0.173$ ,  $P = 0.845$ ), uniformity ( $F_{2,6} = 1.33$ ,  $P = 0.330$ ), strength ( $F_{2,6} = 1.31$ ,  $P = 0.336$ ), and micronaire ( $F_{2,6} = 0.838$ ,  $P = 0.478$ ).

**Table 3.5 Effect of application of different doses of Fruit Boost® on cotton lint quality parameters (mean fibre length, length uniformity, strength, and micronaire) measured using High Volume Instrument (HVI).**

Measurement	Treatment (Mean ± SE)*		
	50 EQE	500 QEQ	Control
Length (mm)	1.18 ± 0.01	1.17 ± 0.03	1.6 ± 0.00
Uniformity (%)	83.2 ± 0.15	85.4 ± 0.7	84.2 ± 1.4
Strength (g / tex)	28.8 ± 0.3	28.9 ± 1.0	27.5 ± 0.1
Micronaire	4.90 ± 0.15	5.10 ± 0.11	4.93 ± 0.06

\*All values in the same row were not significantly different at  $P < 0.05$

### 3.3.4 Temperature and humidity during the experimental period

Graphs of the diurnal temperature and humidity in the crop during the experimental period (1-4 February 2006), are presented in Figure 3.1. The temperature exceeded 40°C on all days, but reached this temperature by late morning on 1 and 3 February 2006.

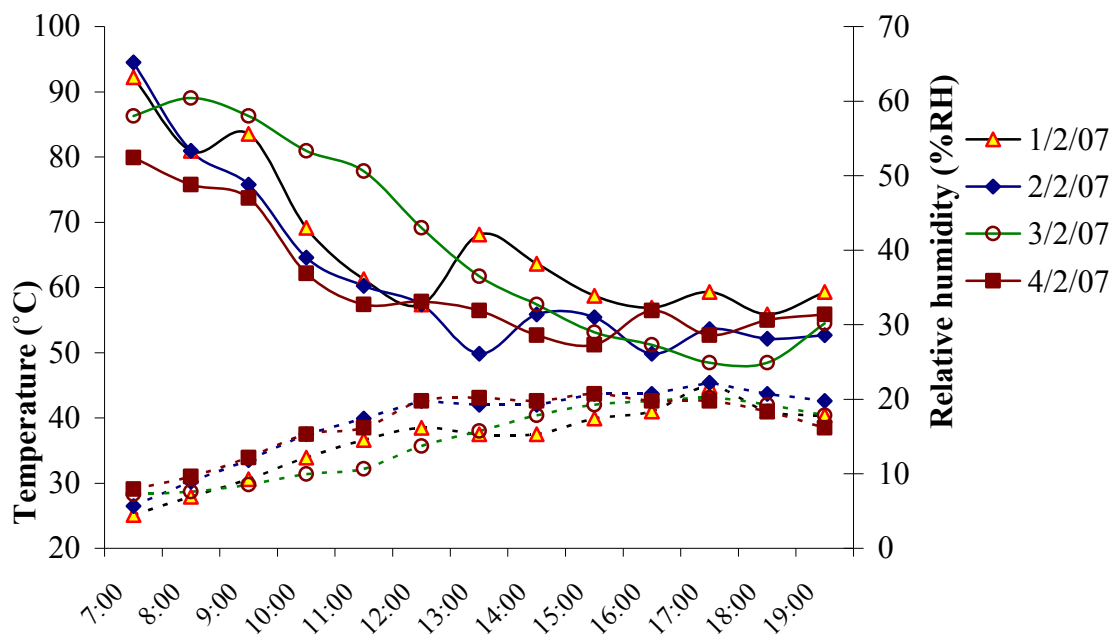

**Figure 3.1 Diurnal temperatures (°C) (.....) and relative humidity (% RH) (—), from 07:00 to 19:00, at the study site during the 4 d experimental period, February 2006.**

### 3.4 DISCUSSION

The bee attractant Fruit Boost<sup>®</sup>, tested in this study, did not attract honeybee foragers to cotton flowers, either on the day of its application or the subsequent day. As a result, there was no increase in fruit set, yield, or lint quality compared with the water-only control.

Fruit Boost<sup>®</sup>, has been used successfully in pollination as a management tool to stimulate bee foraging behaviour (Higo *et al.*, 1995), and to increase fruit set, yield and fruit size in a range of horticultural crops (Currie *et al.*, 1992a, b; Mackenzie & Averill, 1992; Winston & Slessor, 1993; Naumann *et al.*, 1994). In other horticultural crops such as apple, cherry, and kiwifruit, results with QMP have been less encouraging (Winston & Slessor, 1993; Naumann *et al.*, 1994; Howpage, 1999). There are no published data on its use in field crops.

In the current study, mean boll weight, weight of lint / boll and the number of seeds / boll increased slightly, although not significantly, in the QMP treated plots without any increase in number of bee visits. Also, all lint quality parameters were slightly higher, although not significantly, in 500 QEQ treated plots, suggesting that yield and lint quality may be improved by application of pheromone even when bee activity (as measured by the number of bees / 100 flowers) is not higher. It may be once a bee forager contacts an attractive dose of QMP it remains foraging for longer, visiting more flowers, or spending longer on each flower. Higo *et al.* (1995) reported that foragers stayed significantly longer on blueberry flowers in QMP sprayed plots.

Observations of insect visitation to cotton flowers, in the current study, showed that *A. mellifera* were the only pollinating visitors to flowers. However, the majority of honeybee foragers (77.7%) preferred to collect nectar from outside the flowers and were therefore regarded as non-pollinating bees. The overall bee floral visitation level was 0.53%, but the pollinating bee visitation rate did not exceed 0.11 bees / 100 flowers, which is lower than the reported minimum level for effective pollination of cotton (Moffett *et al.*, 1976d). This may, in part, explain the low percentage of bolls set (Table

3.3). The only other invertebrate associated with cotton flowers during the investigation period was the pollen beetle (see also Chapter 2), but there is no published information about its possible role in cotton pollination (see Chapter 5).

The dose of QMP required to optimise bee flower foraging activity seems to be crop dependent. In the current study, QMP at rates of 50 and 500 QEQ / ha did not increase or decrease bee activity in cotton. In cranberries, for example, QMP at the rate of 100 QEQ / ha has been reported to be the most effective dose rate for increasing bee activity, fruit set and yield. A similar dose-dependent response was found in blueberries with a trend towards increased foraging on plots treated with 100 and 1000 QEQ / ha, and 1000 QEQ / ha was also the best rate tested in apples and pears (Currie *et al.* 1992a, 1992b). However, the application of the same rate on kiwifruit has been reported to reduce bee activity (Howpage, 1999), while concentrations of 0.1 and 10 QEQ / ha in pear and apple (Currie *et al.*, 1992a), 100 QEQ / ha in kiwi fruit (Howpage, 1998), 100 and 500 QEQ / ha in sweet cherry (Naumann *et al.*, 1994), 1000 QEQ / ha in cranberry and blueberry (Currie *et al.* 1992b) and 500 QEQ / ha in blueberry and 100 QEQ / ha in cranberry (Higo *et al.*, 1995), were ineffective in attracting bees to the treated crops. Higo *et al.* (1995) found that bee recruitment was actually higher in lower QMP concentration treatments, and bees from these treatments spent less time in the hive after returning with their nectar loads before emerging to recommence foraging.

Even with the application of the optimal dosage of QMP, subsequent honeybee activity can vary between years. Currie *et al.* (1992a) showed significantly higher bee activity in plots treated with QMP at 100 QEQ / ha in only one of two applications period, in only one of two application periods, but the increase in bee activity did not affect yield. Similarly, Malerbo-Souza *et al.* (2004), using a number of non-QMP attractants such as BeeHere<sup>®</sup>, eugenol, citral, and geraniol in sweet orange, reported that they had different effects on honeybee activity and crop yield in different years. In the current study, the QMP tested was supplied by the producer (PheroTech Inc.) at two rates (50 and 500 QEQ / ha). However the results show that neither of these concentrations was effective. Since this was the first study to explore the usefulness of QMP in cotton (PheroTech Inc., per.

comm., 2005), the study was not set up to identify the optimal dose for use in cotton fields. The study tested QMP at half the rates recommended by Phero Tech Inc., because of our inability to apply water to the cotton crop at the application rates recommended. Therefore the optimum dose for use in cotton fields is still unknown.

Timing applications of QMP on a target crop is an important decision that requires a comprehensive understanding of the flowering pattern and floral biology of the crop, in order to achieve the maximum benefit of using this product. For example, Mackenzie & Averill (1992) reported a significant increase in honeybee visitation to cranberries after the application of QMP, but this was not accompanied by an increase in yield, which they explained was because it was applied when a significant proportion of the plants had finished flowering. QMP, in some cases, may need to be applied more than once depending on the nature of the crop's flowering pattern and the cost of its application. Climatic conditions must also be taken into account before any sprays are applied as extreme temperatures are likely to have serious effects on both bee foraging behaviour as well as plant physiology (i.e. nectar and pollen production).

Cotton flowers open only for one day (approximately from 08:00 to 17:00), and a mature cotton plant may have three open flowers at peak flowering. Accordingly, the number of open flowers per metre could be used as an indicator of the optimal time for application of bee attractants. In the current study, QMP was applied on 1 February and repeated again on 3 February 2006, at peak flowering. Although more cotton flowers were present at the time of the second application, subsequent honeybee visitation was lower, and this was accompanied by lower boll set than occurred after the first application. This could have been because, even if the number of bees in the field was constant, the increased number of flowers would result in a lower calculated visitation rate (as the number of bees / 100 flowers). A second factor may have been the dry soil conditions, resulting from delayed irrigation (see 3.2.1), and its impact on evapotranspiration and nectar production.

Meteorological conditions during the investigation period may have also impacted on honeybee foraging activity, crop physiology, and the activity of the QMP. Numerous researchers have reported the effects of weather conditions such as temperature on honeybees, for example, on pollinating activity (Wratt, 1968; Puskadija *et al.*, 2007), honeybee flight activity and nectar gathering activity (Szabo, 1980) and pollen gathering activity in cotton (Wafa & Ibrahim, 1957). Weather during the four days following the first application of QMP, particularly temperatures  $> 40^{\circ}\text{C}$ , was not conducive to bee activity (Figure 3.1). Even in control plots, honeybee numbers decreased sharply on 2 and 4 February, probably as a result of high morning temperatures ( $42.6^{\circ}\text{C}$ ). Figure 3.1 shows that, except for 1 February, temperatures increased gradually to reach  $40^{\circ}\text{C}$  at 11:00, then were between  $40^{\circ}\text{C}$  to  $45^{\circ}\text{C}$  during 12:00 to 19:00. This should be considered as a major factor that restricted bee foraging activity. According to Bodenheimer & Ben-Nerya (1936), bee field activity increases greatly at temperatures between  $34 - 39^{\circ}\text{C}$  mainly due to feverish water-transportation by foragers. In addition, it appears that high temperatures seriously affect cotton plant physiology since on hot days ( $\geq 40^{\circ}\text{C}$ ) the flowers contain no nectar (El-Banby *et al.*, 1985). Therefore, the increased demand for water by the hive combined with the lack of nectar availability may play a significant role in the recruitment and behaviour of honeybee foragers. They would be more likely to shift their activity from nectar and pollen collection to water gathering to assist in preventing the brood from overheating. The effect of the high temperatures on cotton pollen viability may also explain the generally low boll set recorded during this study. Pollen does not germinate at temperatures above  $42^{\circ}\text{C}$  (Barrow, 1981).

Another possible explanation for the lack of effect of the treatment is the volatilisation of the QMP at high temperatures. There is little information published on effect of high temperatures on performance of QMP, although Currie *et al.* (1992b) suggested that QMP had the most economical outcome on cranberry yields during years when weather conditions for bee flight were adverse, although presumably because of low and not high temperatures. Another three year study on cranberries by Malerbo-Souza *et al.* (2004) using BeeHere<sup>®</sup> and other attractants on sweet orange found that they had different

effects on honeybees in different years. This was believed to be related to the different climatic conditions, which may have influenced volatilisation of the attractants.

As cotton in Australia and many other countries flowers in the middle of summer, high temperatures are often associated with the period of cotton pollination. Under such unfavourable conditions it is difficult to assess the efficacy of any bee attractant.

Honeybee visitation is determined by meteorological conditions, the duration, attractiveness and density of flowering and bee stocking rate (McGregor, 1976; Free, 1993). Pollination intensity (the number of pollen grains per stigma), as well as percentage fruit set, the quantity and quality of the resulting fruit and, thus, economic returns must all be determined to confirm that pollination has, indeed, been improved. Many studies concentrate on bee activity and ignore one or more of these other important measurements.

Results presented from this study are based on a single year's data, which may be inadequate to properly assess the efficacy of QMP in cotton pollination under Australian conditions. As has been indicated in overseas studies, the efficacy of Fruit Boost® may vary as a result of external factors such as weather (Currie *et al.*, 1992b; Malerbo-Souze *et al.*, 2004). Therefore similar studies should be undertaken in several locations for at least two consecutive seasons, to obtain more definitive results on the efficacy of QMP in cotton under Australian conditions.

### **3.5 CONCLUSIONS**

- Application of QMP at rates of 50 and 500 QEQ did not result in a significant increase in honeybee foraging activity, fruit set or yield under my study conditions.
- These results are inadequate to conclude that QMP is effective as a pollination enhancement chemical in cotton, due to the high temperatures experienced during

this trial. Additionally, the rates of QMP tested may not have been those effective for attracting honeybees to cotton flowers and, thereby, increasing pollination.

- Nevertheless, based on this study and given normal weather conditions which occur during cotton flowering in Australia, it appears that farmers may be better investing financial resources to rent additional colonies of honeybees for cotton pollination rather than investing in commercial honeybee attractants.
- Presence of pollen beetles in flowers may have reduced their attractiveness to honeybees, even in the presence of an attractant. Investigations on this topic are presented in Chapter 5.



## CHAPTER 4

### **HONEYBEE FIELD ACTIVITY, POLLINATION EFFECTIVENESS AND INFLUENCE ON YIELD PARAMETERS IN TRANSGENIC BT COTTON**

#### ***4.1 INTRODUCTION***

Honeybees annually contribute A \$ 1.7 b to the economy of the Australia (Gordon & Davis, 2003) through crop pollination, and in the United States and Canada this figure has been estimated to be US \$ 14 b (Morse & Calderone, 2000), and US \$ 1.4 b (Scot & Winston, 1984), respectively. Honeybee pollination of crops improves total yields by increasing fruit set, size, shape and seed number and in oil seed crops by increasing seed number, seed size and oil content (McGregor, 1976). Despite these benefits, use of honeybees in cotton crops is very limited.

Cotton, as with many crops that utilize insect pollination (although in cotton primarily for other reasons such as pest resistance and induction of secondary pests), has seen a strong development of pest management strategies that include the judicious use of insecticidal sprays. For honeybees, the timing of these sprays is often critical. This means that harmful pesticides are applied either prior to the bees being moved onto the crop or after their removal, so that foraging bees are not exposed to pesticides or their active residues. Under pressure to achieve timely application of insecticide sprays, growers sometimes use methods and materials that endanger bees. Unfortunately, these strategies need to be considered on an area-wide rather than an individual farm basis. While one grower may apply insecticides to his crop after bees had been removed, there may be colonies in a neighbour's field. Since bees have a large foraging range of 5 km or even more (Ribbands, 1951; Seeley, 1985) and do not recognize fence lines many bees can be killed under such circumstances.

Crops may also be sprayed with highly residual or systemic insecticides prior to bees being moved into the area, leaving toxic residues on leaves and flowers or in the nectar.

In Australia, as cotton growers historically frequently applied pesticides to control insect pests, beekeepers avoided locating their colonies near cotton fields. It was expected that with the widespread introduction of transgenic Bt (Bollgard<sup>®</sup> II) cotton, which provided good protection against the key lepidopteran pests, *Helicoverpa* spp., pesticide applications would be reduced up to 75% (Anon, 2004), and beekeepers could again utilize cotton as a melliferous crop, as well as possibly contributing to cotton pollination. Unfortunately, in the absence of broad-spectrum synthetic pesticides, infestations of some secondary pests of cotton such as green mirids, *Creontiades dilutus* (Stål), spider mites, *Tetranychus urticae*, thrips particularly onion thrips, *Thrips tabaci* Lindeman, and tomato thrips, *Frankliniella schultzei* (Trybom), and aphids, especially *Aphis gossypii* (Glover), have increased, causing economic damage that requires control (Mensah 2002, Whitehouse *et al.*, 2007). Of these, the major pest present at the squaring and flowering stages is green mirid, and the most widely used pesticide for its control is fipronil (Regent<sup>®</sup>) which is highly toxic to honeybees.

The flowering period of cotton is approximately 5-6 weeks; optimizing the pollination service period could be a solution for both beekeepers and cotton growers. One goal of this study was to explore if ten days during peak cotton flowering would be a sufficient period for pollination. This time frame is unlikely to interfere with existing insecticide application programs (Mensah, per. comm., 2005).

With the introduction and widespread use of transgenic Bt cotton, insect resistance to the Bt toxin is a major concern to growers. One way that insects such as *Helicoverpa* spp. can develop resistance is by exposing Bt cotton plants with sub-lethal doses to ovipositing moths (Mensah per. comm., 2008). Thus, gene flow from Bt to conventional cotton varieties is one of the mechanisms that can result in the in-field production of cotton plants with sub-lethal doses of the Bt toxin.

In plants, dispersal of pollen and seeds cannot be observed but can be inferred from the properties of pollinating and dispersing agents. Levin & Kerster (1974) provide an excellent review of this literature. For both wind-dispersed and animal-dispersed pollen,

the distribution of dispersal distances probably underestimates the actual extent of gene flow (Slatkin, 1985). Although cotton is largely self-pollinating and not wind dispersed, there is potential for pollen from Bt plants to be dispersed by insect pollinators, such as honeybees. The average distances travelled by insect pollinators, particularly honeybees and butterflies are generally short and distribution is often extremely leptokurtotic (Levin & Kerster, 1969). However, honeybees travel longer distances when plants are at lower densities.

In Australia, cotton growers and beekeepers generally follow overseas recommendations as local information on pollination of this crop is scarce. This chapter presents outcomes from observations and experiments conducted to find more definitive answers on:

- (1) The effectiveness of honeybees as pollinators of commercial Bt cotton.
- (2) The relationship between high bee stocking rate and optimum pollination period for cotton.
- (3) The foraging behaviour of honeybees in Bt cotton, because much emphasis has been placed on pollen foraging and pollen transfer because of the importance of pollen as the particulate matter transferred and also because little is known about cotton pollen foraging as compared to nectar foraging , and
- (4) The gene flow from Bt cotton to conventional cotton, associated with honeybee foraging.

The investigations attempted to assess ten days as a minimum period for effective cotton pollination, so that cotton growers could be provided with a window within their cotton pesticide program schedule, when bees could contribute to cotton pollination without being exposed to hazardous pesticides.

## ***4.2 MATERIALS AND METHODS***

### ***4.2.1 Location***

Field studies were conducted at the ACRI Narrabri, on commercial cotton crops during summer of 2006-07. The major site was a 2 ha block of irrigated Bollgard®II Sicot 71BR

cotton. The field was subjected to normal farm activities including pesticide applications (except that no insecticides were applied immediately prior to, nor in the presence of hives) during the research period. Cotton commenced flowering on 15 January 2007.

#### **4.2.2 Honeybee pollination efficacy**

Pollination efficacy of honeybees in the cotton crop was measured by assessment of the visitation rate of bee foragers to cotton flowers, and their influence on the yield by collecting samples from treated plots for laboratory quantitative and qualitative measurements.

Colonies of *A. mellifera ligustica*, headed by sister queens, were housed in Langstroth hives each having two deep brood chambers of 8-frames including brood (sealed, unsealed brood and eggs), stored pollen and honey; also one empty super was provided. A total of 32 bee hives, thus a stocking rate of 16 colonies / ha, were imported on 26 January 2007 when 15-20% of the plants were flowering. Moving bee colonies into unattractive crops, such as cotton, after the flowering has reached 10 to 20% helps to prevent foragers from immediately visiting competing crops, thus, increasing visitation to the target crop (Free *et al.*, 1960). The hives were placed adjacent to the field, approximately 20 m away, and were set in one group on the ground and without shading.

##### **4.2.2.1 Treatments**

The effectiveness of honeybees in pollinating transgenic Bt cotton grown on a commercial scale was estimated by using the middle row (row 50) of the cotton field, which was 70 m from the location of the honeybee colonies. The row included 15 plots arranged in a completely randomized block design (RCBD). These were located in five blocks, with each block comprised of one replicate of each of the three treatments. Each plot consisted of two rows of cotton 2 m long, and plots were 10 m apart (Figure 3.1). There were approximately 40 plants in each plot, and all plants were of similar size and stage of development. The treatments were:

I. *No access to honeybees (NB)*

Honeybees were excluded from the plants by caging the plots during the entire flowering season. Cages of 2.0 mm white mesh (measuring 2.0 × 1.5 × 1.8 m) were erected on 26 January 2007, at 07:00 on the same day that the bees were introduced (at 10:00). Each cage enclosed two rows of cotton. In order to minimize any cage effects, all cages were dismantled immediately after completion of the main flowering period, 25 days after they were set up (from 26 January to 19 February 2007).

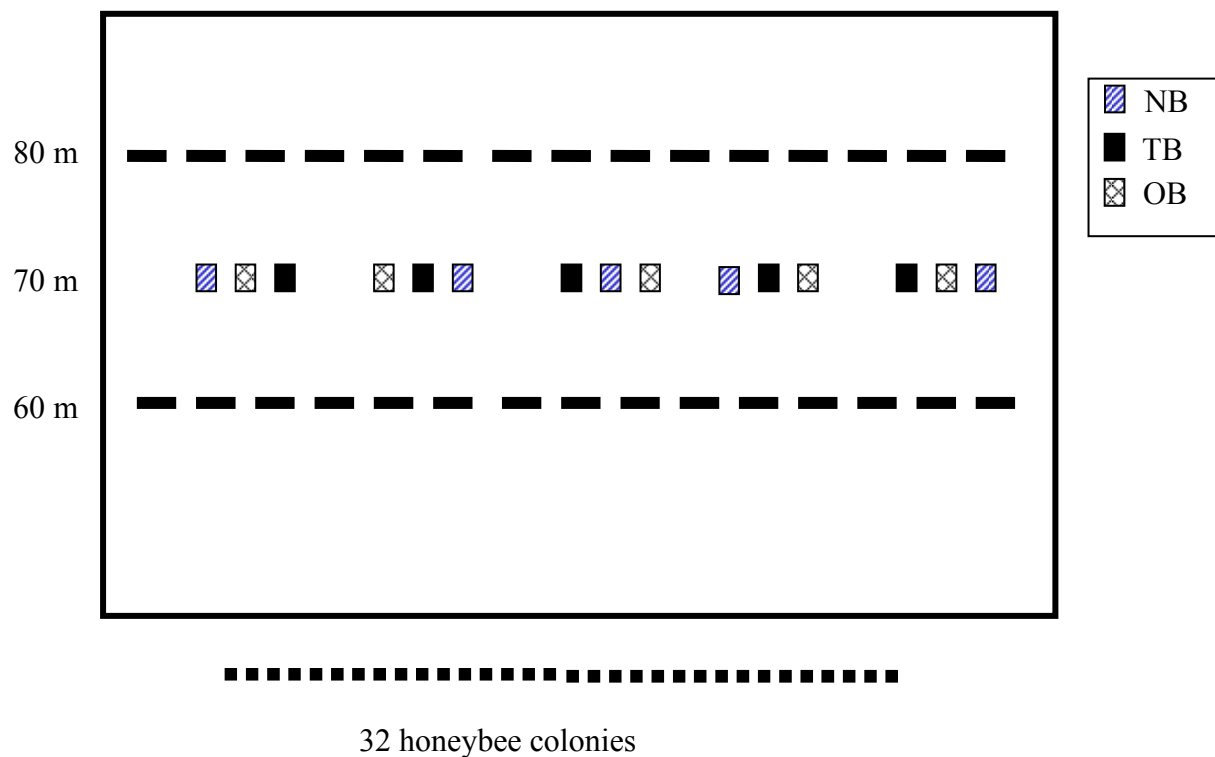

**Figure 3.1 Experimental design of the 2 ha field site, caged (NB): Temporarily cage (TB): open plots (OB) used to assess the pollination efficacy of honeybees, and 30 plots (10 m long) used to determine bee visitation rate to cotton flowers during the investigation period.**

## II. *Open access to honeybees (OB)*

Plots of a similar size as those above were allowed access by the managed bees from the nearby apiary (at a high stocking rate of 16 colonies / ha) as well as by any other pollinating insects, during the entire flowering season. However, the honeybees were free to visit any plants within their foraging range.

## III. *Temporary access to honeybees (TB)*

Similar cages as described in Treatment I were used during the flowering period to exclude honeybees from cotton flowers for a period of 10 d during the peak flowering period. Cages were erected on treatment plots from 2-11 February 2007, after which they were dismantled.

### ***4.2.2.2 Assessments of honeybee foraging activity***

Foraging activity of honeybees was evaluated by recording both the number of out-going bees from the hives, and the number of honeybees on cotton flowers. All counts were made between 10:00 and 14:00, which is the period when cotton flowers are most fully open and have the greatest rate of visitation by honeybee foragers (Moffett *et al.*, 1975a). Observations in the field had already confirmed that flowers were not fully open before approximately 10:00 and that bee activity began to wane after approximately 15:00 as the flowers changed colour (Figures 2.14, 2.16).

#### *I. Bee flight activity*

Foraging activity of out-going bees can be used as a good indicator of the field conditions and food availability. Total flight activity in each colony was estimated on the same day that bee flower visitation data were taken: these dates were 29 and 31 January and 5, 7, 9, 12 and 14 February 2007. Ten colonies were randomly selected for this measurement. The number of foragers departing over a 30 sec interval was counted twice, at 11:00 and 13:00. This methodology has been described in detail in Chapter 2.

## *II. Bee visitation to cotton flowers*

Honeybee visitation rate to cotton flowers is one indicator of pollination efficacy. To investigate the effect of bee visits to cotton flowers in the field, a total of 30, 10 m long plots were established in two sets of 15 plots at distances of 60 and 80 m, respectively, from the apiary location. These 10 m plots were approximately 5 m apart; and were marked out along each row by using 2 m long coloured plastic posts (Figure 3.1).

Data were taken on the same dates I assessed bee flight activity, from the onset of flowering until the middle of February (i.e. for 25 d). Visual counts of the number of honeybees visiting cotton flowers were carried out at 12:00 and 14:00. The number of pollinating bees and their type of foraging (i.e. pollen or nectar gathering) was also recorded, based on their infloral behaviour and the presence or absence of pollen in their corbiculae. In addition, the number of honeybees collecting nectar from extrafloral nectaries was recorded. The bee visitation rates were assessed and calculated as described in Chapter 2. During the assessment, any non-*Apis* visitors to cotton flowers were also recorded.

At the same time, the average number of freshly opened flowers in the experimental field was determined by averaging the total number of freshly opened flowers in the 30 study plots. These data were taken twice a week during the study period to assess the flowering pattern of cotton during the season, as well as honeybee visitation rates.

I undertook other observations to provide a comprehensive description of honeybee foraging behaviour on cotton (e.g. food gathering, pollen rejection). Additionally, foragers were individually collected while they were visiting flowers. This was done by carefully covering a cotton flower with a piece of black cloth which had a hole in its centre which was fitted with a glass vial. Because of their positive phototaxis (Gary & Lorenzen, 1988), the bees walked straight into the vial when exiting the flower, after which they were frozen and stored prior to undertaking microscopic studies. Specimens were observed under a stereomicroscope (Leica MZ12 with a KY-F1030 JVC digital camera) to observe corbiculae with cotton pellets, and for SEM studies (see Chapter 2).

Another investigation was carried out in UWS to explore the attractiveness of cotton nectaries (floral and extrafloral). Thirty cotton plants (15 Bollgard<sup>®</sup> II and 15 conventional) were grown in 8L plastic pots (for more details see 6.2.2.2) (it is illegal to grow transgenic cotton in the ground outside cotton growing areas) and, when flowering, were randomly placed in a line adjacent to an apiary of 50 honeybee colonies at the UWS apiary, Richmond NSW. Plants were examined regularly for a two week period, to record any honeybee foraging activity on flowers or extrafloral nectaries.

### ***III. Pollen gathering activity:-***

To monitor the pollen influx, hives were fitted with pollen traps of 30% efficiency (described in Chapter 2). Pollen was collected on a weekly basis from 26 January to 19 February 2007.

#### ***4.2.2.3 Cotton yield measurements***

Boll set, cotton lint, and seed yield were the direct measurements used to assess the efficacy of bee pollination. Bolls from all plots were hand-harvested and counted on 13 April 2007, when they were fully opened. The number of plants in each plot, and the number of opened bolls were then recorded. Each plot was collected separately, and bolls were placed into bags for processing in the laboratory at ACRI. Cotton samples were debarred, ginned and evaluated for quantitative and qualitative parameters.

After ginning, lint from each replicate was mixed separately by hand, and 30.0 g samples were taken from each, for quality assessment. High Volume Instrument (HVI) testing was used to determine lint quality: micronaire, length, uniformity and strength (see Chapter 1).

#### ***4.2.3 Cotton gene flow***

##### ***4.2.3.1 Experimental design***

This experiment, conducted simultaneously to the honeybee pollination efficacy trial (4.2.2), was to assess whether any gene flow occurred, via dispersal of pollen from Bt cotton plants to the central row of a test plot of conventional cotton, in the presence of



relatively high numbers of managed honeybees. This work was made possible because of the co-location of plots of both cotton varieties at ACRI, which had been used for unrelated investigations. The trial was located at a site one kilometre from the apiary (described in 4.2.2). The investigation field comprised two plots of Bollgard® II Sicot 71 BR, with one plot of conventional cotton (Sicot 71) between them. The conventional cotton plot thus comprised 24 rows each 50 m long, in the middle of two plots of similar size Bt cotton, with an orientation of the longest sides adjacent. Buffers of 4 m of a flowering sunflower crop more than 2 m high were located between the Bt and conventional cotton plots. All cotton plants were at the same stage of development, and all plots were flowering.

#### ***4.2.3.2 Sampling and testing protocol***

Twenty-five flowers in the central row of the conventional cotton plot (i.e. 16 m away from the Bt variety), and subjected to normal bee and other pollinator visitation, were randomly tagged on each of 28 January and 4, 11 and 18 February, 2007 (to include samples from early, peak and late flowering periods). All tagged, matured bolls were hand-harvested and ginned to obtain seeds (as described in 4.2.2.3) which were then tested individually by ACRI staff, using the ELISA assay, for the presence of Bt gene(s) (*CryIAc* and *Cry2Ab*). Details of this methodology are presented in Appendix I.

#### ***4.2.4 Recording meteorological conditions during investigation period***

Temperature and humidity data were collected during the investigation period, as described in Chapter 2.

#### ***4.2.5 Statistical analysis***

Data were analyzed using ANOVA, General Linear Model, SPSS® for Windows™ Version 14 (SPSS Inc. 2007). Prior to analysis each variable was visually tested for normality using P-P plot and Levene's test was used to test the assumption of equality of error variance.

When significant differences were detected Ryan's Q test was used to separate treatment means if data met the assumption of equality of variance and Dunnett's T3 test was used if the assumption of equality of variance was not met after appropriate transformation of data. In all cases, significance was accepted at the 0.05 level.

The relationship between the number of cotton flowers, the number of out-going bees and the bee visitation rate, was explored by using Pearson correlation (Pearson, 1896).

The values are normally presented as mean  $\pm$  standard error (SE) of the mean (Tables), or bars (Figures).

### **4.3 RESULTS**

#### **4.3.1 Honeybee pollination efficacy**

##### **4.3.1.1 Bee flight activity**

The mean number of out-going bees per 30 sec (from 10 hives) was 33.3, 29.0, 25.5, 13.3, 18.5, 19.1 and 24.5 on 29, 31 January, and 5, 7, 9, 12 and 14 February 2007 (Table 4.1). In general, the number of outgoing bees was highest at the beginning and the end of the investigation period.

##### **4.3.1.2 Bee visitation to cotton flowers**

###### *i. Bee visitation rate*

A total of 9864 cotton flowers were recorded during this study, and a total of 344 bee foragers were observed visiting these flowers. Therefore, the average bee visitation rate to cotton flowers was 3.49 bees / 100 flowers (Fig 4.2), ranging from 1.27 to 6.83 at any given time. A decline in bee visitation rate during the middle of the flowering period is shown in Figure 4.2.

The total number of bees observed in cotton flowers was 36, 69, 80, 46, 51, 36, and 24 on 29 and 31 January and 5, 7, 9, 12 and 14 February 2007, respectively, when the number of flowers per 10 m plot was 27.6, 22.7, 32.0, 30.0, 24.5, 17.7 and 9.1 (Table 4.1). There was moderate correlation between the number of cotton flowers and the number of

flower-visiting bees ( $r = 0.649$ ), but no correlation between the number of out-going bees and the number of flowers ( $r = -0.023$ ), nor with bee visitation rate ( $r = 0.120$ )

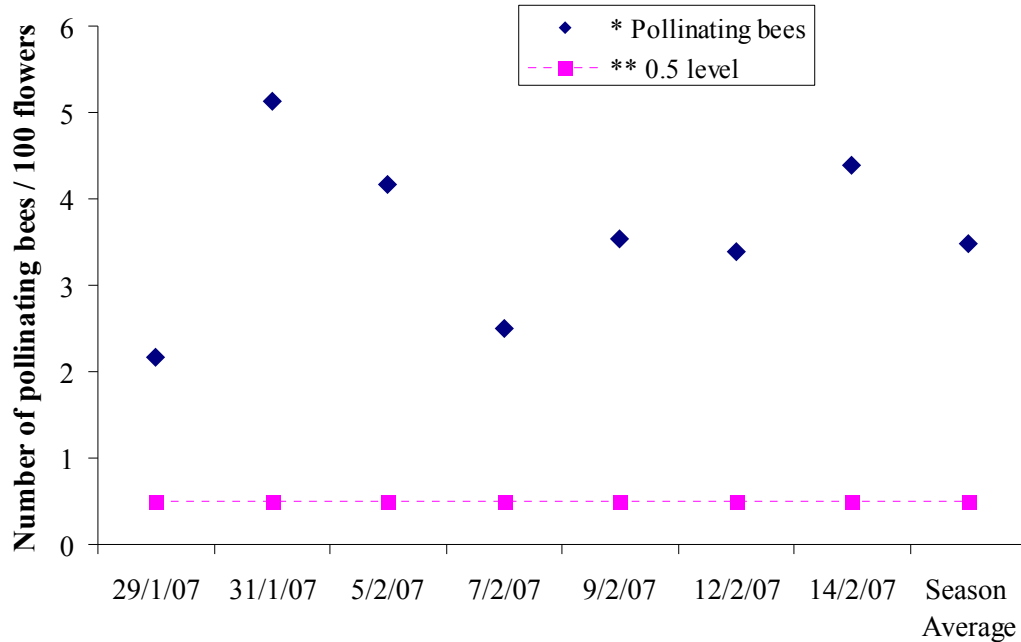

**Figure 4.2 Honeybee, *Apis mellifera* L., visitation rate (number of pollinating bees / 100 flowers) monitored on cotton flowers during the investigation period.**

\* Data were taken at 12:00 and 14:00 (30 plots, 10 m long)

\*\* Minimum level required for adequate cross-pollination

**Table 4.1 The relationship between number of cotton flowers, number of out-going bees and number of bees recorded on cotton flowers (season 2006-07).**

Date of observation	January			February			
	29	31	05	07	09	12	14
Mean number of flowers* / metre	2.76	2.27	3.20	3.00	2.45	1.77	0.91
Number of cotton flower visiting bees*	36	70	80	46	52	36	24
Mean number of out-going bees**	33.3	29.0	25.5	13.3	18.5	19.1	24.5

\* Data were taken at 12:00 and 14:00 (30 plots, 10 m long)

\*\* Data were taken from 10 colonies / 30 sec, at 12:00 and 14:00.

*ii. Diurnal bee visitation to cotton*

Of the 338 bees observed on cotton flowers; the majority (279, 82.6%) were collecting nectar from floral glands while the rest (59, 17.4%) were collecting pollen (Figure 4.3).

The nectar gathering activity of the honeybees, which is correlated with nectar secretion and nectar availability, was nearly at the same level in the morning at 12:00 (141, 51%) as in the early afternoon at 14:00 (138, 49%). Pollen gathering activity, which is related to pollen release, was higher in the morning at 12:00 (41, 69%) than early afternoon at 14:00 (18, 31%).

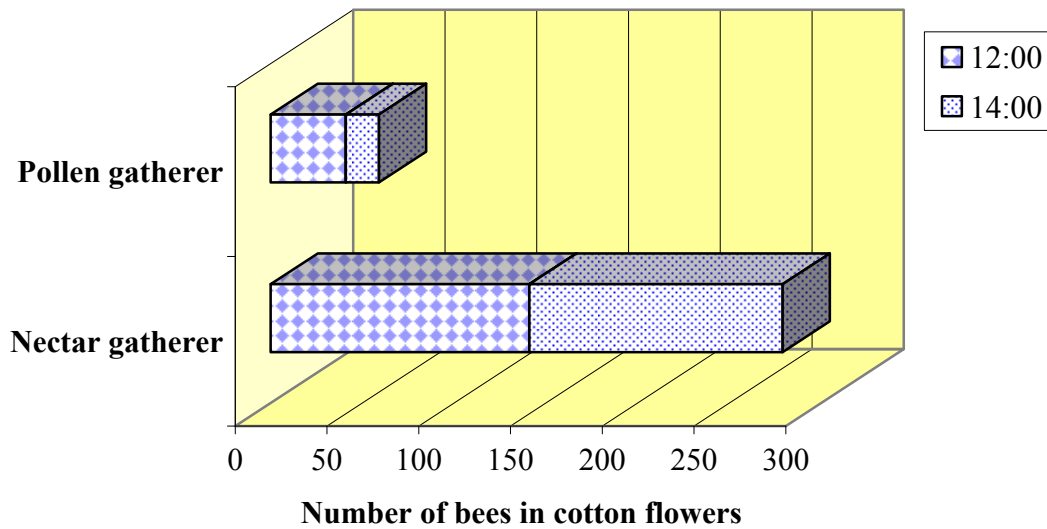

**Figure 4.3 Honeybee foraging activity (collecting nectar or pollen) in cotton flowers at peak field foraging activity.**

*iii. Honeybee foraging behaviour*

In the current study, extensive observations on the behaviour of individual bee foragers on cotton flowers were carried out to obtain a comprehensive understanding and to provide a detailed description of these behaviours, which are described thus:

(a) *Nectar gathering bees:*

Nectar gathering bees alighted on a flower, on the petals or stamens, walking to the base of the style, where the nectaries were located, to collect the floral nectar. Most of bees kept their legs on the petals (rarely on the stamens), with the dorsal side of their body towards the anthers and, by doing this, their bodies were accidentally dusted with pollen grains. This provided a second chance for pollen deposition on the stigma. The hairs of the bees were now covered with pollen, with the current flower's own pollen predominating, increasing the chance of self-pollination. Handling time varied from 5-20 sec; this was probably related to nectar availability. After collecting the nectar the foraging bees walked out along the petals, keeping their head downwards, and once clear of staminal column, flew directly from the petals to the next flower. When the bees had collected a full load of nectar, and before returning to the hive; they were commonly observed on cotton leaves, grooming themselves to remove cotton pollen. Confirmatory observations were undertaken by following individual flying bees identified as nectar gatherers and dusted with cotton pollen, to determine their foraging task; all dusted bees landed on flowers to collect nectar and none of them collected pollen. Thus, the observed grooming behaviour was associated with nectar gathering bees. Some field honeybees collected floral nectar with a different behaviour; they sucked the floral nectar from outside the flower by inserting their proboscis in the space between the calyx and corolla; thus, these foragers were not dusted with any pollen.

(b) *Pollen gathering bees:*

Pollen gathering bees usually alighted on the stamens of cotton flowers, lightly touching the petal tips with their legs. While doing so they (carrying on their body pollen from other flowers) often brushed past the protruding stigma, and, thus, effected cross-pollination. Handling time of the pollen collectors was shorter than for the nectar gatherers, at 5-10 sec. The pollen gatherers quickly started to collect pollen grains in the corbiculae of their hind legs; they frequently pushed and pulled the anthers aside with their legs as they moved around and over the stigma. This provided a second chance for pollen deposition on the stigma. After working in this way on one flower, the bees moved to the next flower and repeated the process, until their pollen load was complete. Figure

4.4 shows two scanning electron micrograph images of cotton pellets in the corbiculae of pollen gathering honeybees collected during the current investigation.

Although a relatively high number of bee foragers were observed on cotton flowers, none of these visited the extrafloral nectaries of the bracts or underneath the leaves. In the choice experiment, no honeybees were observed foraging in flowers or at extrafloral nectaries, probably because of the presence of surrounding attractive flowering species and/or the small number of cotton plants used. However, ants were observed on the bracteal nectaries of the conventional variety only.

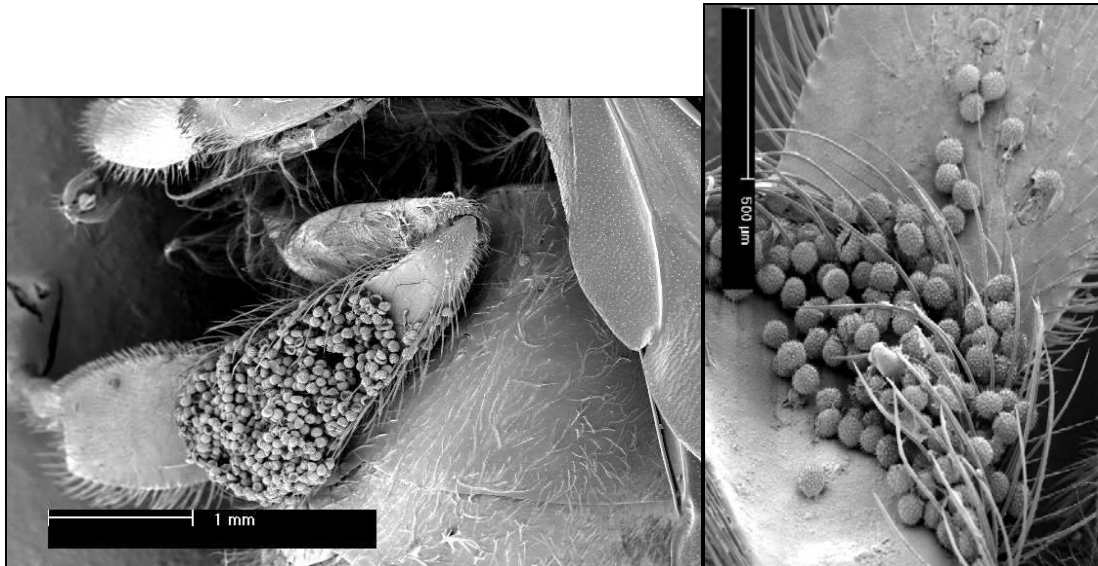

**Figure 4.4 Scanning electron micrographs (SEM) of a pellet of cotton pollen collected by a pollen gathering bee.**

The pollen traps which were installed onto the experimental colonies were invaded by ants, which, despite attempts for their control by application of Mortein Outdoor Ant Sand (Reckitt Benckiser© 2002, West Ryde 2114, NSW) to the ground around the hives, stole most of the pollen collected. Thus, the amounts remaining in the traps were not a reliable indicator of pollen flow, and the data were not used for any analyses or interpretations.

iv. Non-Apis pollinators

Out of the 344 individual pollinators recorded on cotton flowers during the investigation period, 98% (338) were *A. mellifera*; the remaining 2% (6) were all identified as *Lithurgus (Lithurgus) rubricatus* Smith (see Chapter 2.3.4.2).

#### 4.3.2 Cotton yield measurements

Yield data were compared between plots of treatments permanently caged without access to pollinators (bees and other insects) (NB), those exposed to pollinators for 15 d at the beginning and end of flowering (TB), and uncaged plots exposed to pollinators throughout flowering (OB) (Table 4.2). As previously determined, pollinators were almost entirely honeybees. Flowering plants with open access to honeybees (OB) (at a rate of 15 colonies / ha) had significantly higher total boll weight ( $F_{2,15} = 12.247$ ,  $P < 0.001$ ), weight of seed / m ( $F_{2,15} = 12.286$ ,  $P < 0.001$ ), number of seeds / m ( $F_{2,15} = 10.625$ ,  $P = 0.002$ ), and total weight of lint ( $F_{2,15} = 11.842$ ,  $P < 0.001$ ), compared to all other treatments. The two treatments which were exposed to bees for at least 10 d, TB and OB, while not significantly different from each other had significantly more bolls / m ( $F_{2,15} = 10.038$ ,  $P = 0.003$ ), mean boll weight ( $F_{3,15} = 13.113$ ,  $P < 0.001$ ), and mean weight of lint / boll ( $F_{2,15} = 6.558$ ,  $P = 0.012$ ) than the control plots which were never exposed to bees. The only significant difference in the number of seeds / boll was between OB and NB ( $F_{2,15} = 6.010$ ,  $P = 0.016$ ), with OB superior, and, similarly, the number of bolls per plant ( $F_{2,15} = 6.492$ ,  $P = 0.012$ ). There was no significant difference in mean seed weight ( $F_{2,15} = 1.564$ ,  $P = 0.249$ ) between any treatments (Table 4.2).

The contribution made by honeybees to cotton pollination during the peak ten days of flowering was calculated as the difference between the data for 25 d continuous exposure to bees (OB) and data from plants periodically exposed to bee pollination at the beginning and end of flowering (i.e. caged for 10 d [TB]).

The number of bolls / plant, the total number of bolls / m and the total weight of bolls / m attributable to flowers having access to bees for 10 d during peak flowering was between approximately 45-50% of the overall yield for the investigation period of 25 d (Table 4.3),

greater than the relative proportion of time (40%). While the contribution to seed weight / m and mean number of seeds / boll was also approximately 50%, the contribution to the total weight of lint / m was only 35.8%, which was similar to the contribution to mean boll weight (35.3%). Thus, the increase in mean boll weight was a result of increases in seed number and weight, and not in lint production.

**Table 4.2 Effect of different pollination treatments NB: No access to honeybees, TB: temporary access to honeybees (caged for middle ten days), OB: open access to field honeybees for entire investigation period, on cotton yield parameters.**

Measurements	Caged (Mean $\pm$ SE)		Un-caged (OB)
	Permanently (NB)	Temporarily (TB)	(Mean $\pm$ SE)
Number of bolls / plant	4.12 $\pm$ 0.42 <sup>a</sup>	5.15 $\pm$ 0.39 <sup>ab</sup>	6.19 $\pm$ 0.39 <sup>b</sup>
Number of bolls / m	38.40 $\pm$ 3.49 <sup>a</sup>	50.90 $\pm$ 4.16 <sup>b</sup>	61.40 $\pm$ 2.96 <sup>b</sup>
Weight of bolls (g) / m	195.7 $\pm$ 19.3 <sup>a</sup>	277.0 $\pm$ 26.24 <sup>b</sup>	343.2 $\pm$ 16.55 <sup>c</sup>
Boll weight (g)	5.08 $\pm$ 0.07 <sup>a</sup>	5.41 $\pm$ 0.07 <sup>b</sup>	5.59 $\pm$ 0.06 <sup>b</sup>
Number of seeds / m	1059 $\pm$ 110 <sup>a</sup>	1469 $\pm$ 135 <sup>b</sup>	1849 $\pm$ 115 <sup>c</sup>
Weight of seed (g) / m	121.1 $\pm$ 11.8 <sup>a</sup>	170.0 $\pm$ 16.5 <sup>b</sup>	218.1 $\pm$ 12.6 <sup>c</sup>
Weight of 100 seeds (g)	11.47 $\pm$ 0.11 <sup>a</sup>	11.46 $\pm$ 0.18 <sup>a</sup>	11.80 $\pm$ 0.11 <sup>a</sup>
Number of seeds / boll	27.46 $\pm$ 0.45 <sup>a</sup>	28.77 $\pm$ 0.38 <sup>ab</sup>	30.06 $\pm$ 0.69 <sup>b</sup>
Weight of lint (g) / m	74.6 $\pm$ 7.49 <sup>a</sup>	107.0 $\pm$ 9.58 <sup>b</sup>	125.1 $\pm$ 3.94 <sup>c</sup>
Weight of lint (g) / boll	1.93 $\pm$ 0.03 <sup>a</sup>	2.09 $\pm$ 0.01 <sup>b</sup>	2.04 $\pm$ 0.04 <sup>b</sup>

\* Means in the same row followed by different letters differ significantly at  $P < 0.05$

#### 4.3.2.1 Qualitative parameters

Statistical analysis of quality parameters showed that there were non-significant trends for increase in micronaire ( $F_{2,15} = 3.895$ ,  $P = 0.05$  NS), strength ( $F_{2,15} = 1.864$ ,  $P = 0.197$ ), length ( $F_{2,15} = 0.731$ ,  $P = 0.501$ ), and uniformity of lint ( $F_{2,15} = 0.099$ ,  $P = 0.906$ ) (Table 4.3).



**Table 4.3 Effect of different pollination treatments on cotton parameters of lint quality: micronaire, strength, length, and uniformity. Treatments are NB: No access to bees, TB: temporary access to bees, and OB: open access to bees, at ACRI, 2007**

Measurements	Caged (Mean $\pm$ SE)		Un-caged (OB)
	Permanently (NB)	Temporarily (TB)	(Mean $\pm$ SE)
Micronaire	4.92 $\pm$ 0.08	5.12 $\pm$ 0.06	5.14 $\pm$ 0.04
Strength (tex / g)	31.66 $\pm$ 0.54	32.22 $\pm$ 0.32	32.72 $\pm$ 0.27
Length (mm)	1.17 $\pm$ 0.01	1.17 $\pm$ 0.01	1.19 $\pm$ 0.01
Uniformity (%)	83.76 $\pm$ 0.63	83.80 $\pm$ 0.14	84.08 $\pm$ 0.46

\*All values in the same row were not significantly different at  $P < 0.05$ .

#### **4.3.3 Cotton floral phenology**

The yellow cotton flowers commenced to open shortly after sunrise (07:30 - 09:30), with most delays associated with low temperatures the previous night and in the early morning. The colour change in petals from creamy white to reddish pink was observed most commonly around 15:00-16:00 and, at this stage, flowers became less attractive to bees. Flowers usually closed at 16:00-17:30 (8-9 h after opening) and did not reopen. Wilted petals fell off within several days. The number of flowers per plant ranged from 0 - 3.

#### **4.3.4 Cotton gene flow**

Forty bolls were collected from the central row of conventional cotton plants located in the plot between the two Bt cotton plots. Bolls were sufficient to generate 480 seeds. The ELISA test showed that a total of eight seeds (1.66%) tested positive for the presence of the Bt gene, indicating that there was some pollen flow from the Bt plots over the 16 m between them and the conventional cotton plants sampled (Table 4.5).

#### **4.3.5 Temperature and humidity during experimental period**

The maximum, minimum and average temperatures, and average relative humidity, immediately adjacent to the crop during the experimental period (26 January to 19 February 2006), are presented in Figure 4.6. The temperature only exceeded 38°C on 19 February. This provided favourable conditions for bee foraging.

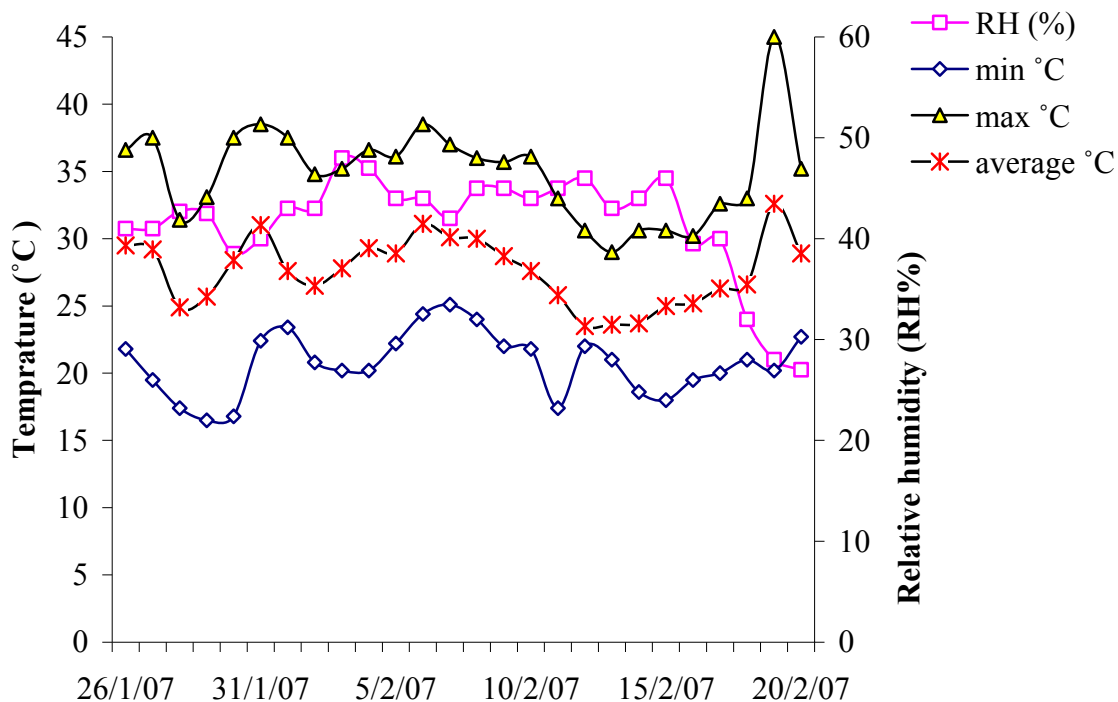

**Figure 4.6 Minimum, maximum and average temperatures, average of relative humidity recorded at the experimental site during investigation period.**

#### 4.4 DISCUSSION

##### 4.4.1 Honeybee pollination efficacy

The cotton yield data reported above suggest that cross-pollination effected by honeybees resulted in higher boll set, and heavier bolls with higher seed numbers, resulting in higher boll weight / m (yield), under the experimental conditions (Tables 4.2). Significantly lower seed numbers in bolls in the NB treatment were mainly due the lack of cross-pollination resulting from the absence of honeybees. These results are similar to those reported by Shishikin (1952), Mahadevan & Chandy (1959), and El-Sarrag *et al.* (1993), but higher than those of McGregor *et al.* (1955), Kaziev (1960), Stith (1970), Tanda & Goyal (1979b), and Rhodes (2002).

Honeybees, however, did not contribute significantly to cotton quality. While there was a strong trend towards higher micronaire in the plots exposed to honeybees, the data were inconclusive. All other parameters were similar in the three treatments. This suggests that honeybees and their associated cross-pollination may contribute more to yield than to lint

quality. This is different to results reported by McGregor (1976), Tanda & Goyal (1979a), and Rhodes (2002) that honeybees improve the lint quality. It is important to note that the quality of lint, in my current study, was high, even in the control treatments. Apart from cross-pollination, lint quality can also be influenced by variety, weather, production practices and ginning processes (Eveleigh *et al.*, 1999).

As there was no recommended hive stocking rate for cotton pollination, flower visitation rate was used as the measurement to assess bee pollination efficacy. In this study, the average visitation rate (at the experimental stocking rate of 16 colonies / ha) in the experimental field was 3.49 bees / 100 flowers, which is seven times higher than the level (0.5 bees / 100 flowers) considered adequate by Moffett *et al.* (1976d). The significant increase in number of bolls / plant could be considered as an outcome of honeybee flower visitations, while the increased quantity of seeds and weight of lint / boll reflect the pollen transfer efficacy from these pollination visits.

The high honeybee visitation rate I recorded was probably due to a number of factors:

- (1) *A high stocking rate*: of 16 colonies / ha .
- (2) *Absence of pesticides*: the investigation period provided a safe environment for honeybees, because no insecticides were sprayed during the flowering of this cotton crop.
- (3) *Few competing floral sources*: there was relatively low competition by non-*Gossypium* flowers. The area surrounding the cotton study site had a restricted range of alternative pollen sources, because most of the surrounding area was planted with cotton and there were no cultivated crops nearby.
- (4) *Favourable climatic conditions*: the prevailing drought conditions limited the presence of other flowering weeds and herbs, except for irrigated cotton crops. Temperatures during the study were also favourable for honeybee foraging activity.

As the presence of feral honeybees was not assessed, these may have also contributed to pollination. Stocking rates may vary depending on the populations of native pollinators,

the field size and the nature of surrounding vegetation. Thus, USA recommendations for bee stocking rates in cotton are not necessarily applicable for Australian conditions. The assessment of bee activity at early (for example, 25% and 50%) flowering, during times of peak bee activity, could be useful in determining the optimum stocking rate. In the current study, bee activity between 2.2-5.0 and 2.6-4.2 bees / 100 flowers (at 12:00-14:00) at 25% and 50% flowering levels, respectively, resulted in increased pollination and higher boll set.

#### **4.4.2 Honeybee foraging activity**

The detailed observations reported in this chapter (which confirm limited observations reported in Chapter 2) support earlier reports of repellence or rejection behaviour to cotton pollen by honeybee foragers (McGregor, 1976; Tanda & Goyal, 1979b; Moffett & Stith, 1972a; Loper & Davis, 1985; Rhodes, 2002). However, it suggests that pollen rejection was only associated with nectar gathering bees, and even then, only prior to them returning to the hive. My observations showed that none of the flower-visiting bees with bodies dusted with pollen were collecting pollen, only nectar. This confirms that the pollen grooming behaviour was associated only with nectar gathering bees. These observations are logical, because it would be inexplicable for pollen gatherers to groom themselves after having initially collected the pollen.

Many pollen gathering bees comb pollen grains from their bodies into their corbiculae, whereas some scrape and discard them from their bodies (Free, 1993). Similar behaviour was first recorded by Synge (1947) for bees visiting sunflower, *Helianthus annuus* L., and has been subsequently observed on this species and also on dandelion, *Taraxacum officinale* Wigg. (Free, 1968a), raspberry, *Rubus idaeus* L. (Free, 1968b) and oilseed rape, *Brassica napus* L. (Free & Nuttal, 1986).

Although this study concludes that only nectar gatherers reject cotton pollen, the reasons for this behaviour are still unknown. Pollen rejection has been explained by other authors as being a result of the large size of cotton pollen grains (Vansell, 1944; Buchmann & Shipman, 1990), length of spines on pollen grains (Vaissiere & Vinson, 1994), and/or

presence of gossypol (Moffett *et al.*, 1983). However, bees have been reported to effectively collect cotton pollen under caged (Eisikowitch & Loper, 1984) or field conditions (Danka, 2005), which suggests there is no physical problem interfering with pollen collection by honeybees.

The observation of pollen gatherer bees on cotton flowers and at the hive entrance showed that the yellow-creamy pellets of cotton pollen collected by honeybee foragers were very small compared with non-*Gossypium* pollen pellets. This is similar to the results previously reported in Chapter 2, and likely reasons for this have been discussed there.

Despite this, however, the observations in the current investigation suggesting the likelihood of pollination by infloral nectar-gathering bees, is consistent with the reports of Tanda & Goyal (1979), who measured the distances between stamens and stigmas to the petals of fully opened cotton flowers as well as the maximum body width for honeybee foragers, and stated that foragers could never collect nectar without physically rubbing their body against the anthers. Similar conclusions about the effectiveness of nectar gatherers as pollinators have been made in other crops, such as red clover (Wafa & Ibrahim, 1959) and kiwifruit (Goodwin, 1992).

Approximately 12% of all honeybee foragers on cotton flowers in the current trial collected cotton pollen (the remainder collected floral nectar from within or outside the flower). This is similar to results reported by Tanda & Goyal (1979b).

The current study indicated that both pollen gathering and nectar gathering bees facilitated cross-pollination in cotton flowers. Both types of foragers were observed to be contaminated with pollen, either intentionally (pollen gatherers) or accidentally (nectar gatherers) after being in direct contact with the stamens. However, the relationship between what the nectar gathering bees carried on their bodies and what the pollen gathering bees carried on their bodies or in their corbiculae is still unknown. The likely

important cross-pollination role of nectar gatherers in cotton is, thus, supported by the following:

- (1) Nectar gatherers were observed to spend more time on individual flowers during nectar collection.
- (2) They are likely to transfer a high number of pollen grains from their highly dusted bodies because the bee usually touches the stigma on arrival at the flower as well as when working the infloral nectaries. Tanda & Goyal (1979) stated that foragers cannot collect nectar without physically rubbing their bodies against the anthers.
- (3) The number of nectar gatherers was much higher than pollen gatherers.

Pollination efficacy by nectar gatherers is likely to be related to time of day. The cotton flower stigma is most receptive to pollen in the morning (Janki *et al.*, 1968) and the highest nectar collection activity I recorded was between 12:00 and 14:00. In addition, when a cotton flower first opens, all the petals are tightly pressed against each other, with no space between them. Bees visiting a flower at this time to feed from the infloral nectary must crawl down to the base of the flower along the space between the stamens and corolla. In the afternoon the petals lose their turgidity and tend to separate out, leaving spaces between adjacent petals; this enables nectar gatherers to exploit the infloral nectaries without touching the stigma and stamens (Wafa & Ibrahim, 1957, 1959).

The pattern of bee visitation during the cotton flowering period showed a mid-season reduction. This is consistent with the findings of Moffett *et al.* (1979a). However, it differed from reports by Weaver (1978) of a reduction in bee activity in late flowering, by Vaissiere (1992) that bee activity continued to drop from initially high levels, and by Danka (2005) who observed highest activity during the middle stages of flowering. These differences in flower visitation may be more a reflection of the internal factors within honeybee colonies or environmental conditions, rather than the inherent attractiveness of the cotton flowers. Factors influencing bee visitation to cotton flowers have been discussed in detail elsewhere in this thesis. However, the reasons for the different patterns of bee foraging behaviour in cotton are still unclear and need further investigation.

In this investigation, *A. mellifera* was by far the most common pollinator observed, making up approximately 98% of pollinators visiting cotton flowers (this excludes pollen beetles, see Chapter 5). The remaining 2% of pollinators were all identified as the solitary megachilid bee, *L. rubricatus*, the same species recorded in my previous investigations, and reported in Chapter 2. Cotton crops are known to attract large numbers of insects. However, the frequent use of pesticides has reduced many of the beneficial arthropod species in conventional cotton. It appears that this may also be the case in flowering Bollgard II cotton.

#### **4.4.3 Cotton yield measurements**

Yield data were used to assess the contribution to cotton pollination resulting from access to honeybees for periods of 10 and 15 d. Providing access to bees for a 15 d period during the beginning and end of flowering significantly increased number of bolls / m (by 32.5%), weight of bolls / m (41.1%), mean boll weight (25.0%), number of seeds / m (38.7%), weight of seeds / m (40.3%), weight of lint / m (43.4%) and mean weight of lint / boll (6.2%), over plants caged throughout the flowering period to prevent bee access. Providing access to bees throughout the flowering period (25 d) was significantly superior to exposure for 15 d, for weight of bolls, weight of seed per metre, number of seeds per metre and weight of lint. Based on the differences between the 15 d and 25 d bee access periods, for most parameters (although not all are significant), the contribution of a 10 d honeybee pollination during peak flowering was similar to a 15 d contribution in off-peak flowering. These results demonstrate the important role of honeybees in pollinating cotton, and suggest that allowing honeybees access to flowering cotton crops for 10 - 15 d, while not as good as allowing access throughout the flowering period, is highly beneficial. The use of pesticides hazardous to honeybees during flowering is likely to create a similar scenario to the no-bee treatment, and should demonstrate to growers that if they can provide a non-hazardous period of 10-15 d, yield would be superior to continuous spraying. It may be unrealistic to expect that no pesticides would be applied throughout the flowering period of most cotton crops.

The issue of a possible cage effect in my cotton field trials has already been discussed in Chapter 2.

#### ***4.4.4 Cotton gene flow***

The horizontal transfer of genes from transgenic to non-transgenic cotton varieties is inevitable, as although cotton is predominantly inbreeding, out-crossing is possible through the activity of pollen and nectar feeding insects, particularly honeybees. In this trial a low, but never-the-less important, level (< 2%) of pollen dispersal occurred from the Bollgard®II to the conventional cotton plants, over a distance of 16 m, in the presence of a high honeybee stocking rate in the area. It should be noted, however, that the apiary was approximately 1 km from the experimental field, so this figure could have been higher if the apiary was closer.

While the cross-pollination rate in Australia has been previously reported to be 1-2% for adjacent rows, 1 m apart (Llewellyn & Fitt, 1996) this is lower than many other, mostly overseas, field-based assessments which have estimated cross-pollination in cotton to be up to 10% under similar conditions (Elfawal *et al.*, 1976; Umbeck *et al.*, 1991; Yasour *et al.*, 2002; Van Deynze *et al.*, 2005). Higher estimates of inter-row cross-pollination (17-25%) have been reported (Umbeck *et al.*, 1991; Van Deynze *et al.*, 2005), and furthermore, in USA, very high figures (75%) have been reported in the presence of large numbers of *Bombus* spp. (Oosterhuis & Jernstedt, 1999). Umbeck *et al.* (1991) reported that 1% dispersal of pollen was detected over a 7 m distance, although Llewellyn & Fitt (1996) reported much lower rates of 0.17% over 4 m and 0.03% over 16 m.

Despite the high number of native pollinators, buffer zones between plots of cotton for seed production in Australia have been historically smaller (often only a few metres) than those in the USA (sometimes more than 800 m) (Llewellyn *et al.*, 2007). The difference in the magnitude of the dispersal between the USA and Australia is probably a reflection of the difference in pollinator species, particularly the absence of *Bombus* spp. in Australia (Llewellyn *et al.*, 2007). Because of the low level of cross-pollination of cotton previously recorded in Australia, probably in the absence of managed bees, vectored



pollen movement from Bt plants has not been considered to pose a significant risk either to effective pure seed production or contamination of conventional cotton.

Llewellyn & Fitt (1996) reported that a buffer of 20 m of conventional cotton or 50 m of bare ground was an acceptable containment measure for small scale testing of Bt cotton in eastern Australia. Llewellyn *et al.* (2007) subsequently confirmed the effectiveness of the buffer size in eastern Australia, but suggested that in tropical Australia, a higher rate of pollen dispersal caused by climate, local geography and higher pollinator numbers, may require a buffer of 1 km for breeding lines. My results suggest that even in eastern Australia, the size of the buffer zone may have to be increased in the presence of high numbers of honeybees.

While it is assumed that honeybees and *C. atterimus*, are the most likely potential vectors for cross pollination of cotton in Australia, Llewellyn & Fitt (1996) did not detect any honeybees from field collections in flowering cotton crops, and only small numbers of wasps and flies. They reported that pollen beetle populations were closely correlated with flower production, and they speculated that they were the major pollinators in cotton, and therefore had potential to be vectors for transmission of the Bt gene. While they did not undertake any field studies, Llewellyn *et al.* (2007) presumed that pollen beetles had restricted foraging distances and a preference for open flowers that were already pollinated, and concluded that they would be unlikely to be important agents for dispersal of pollen from transgenic plants to other crops. Studies on pollen beetles and their role in pollination were conducted as part of this thesis, and are reported in Chapter 5.

#### **4.5 CONCLUSIONS**

- Under Australian conditions, honeybees contributed to cross pollination in cotton, resulting in both higher lint yield and at least as good quality lint. Total weight of bolls was reduced by almost half in the absence of honeybees. The likely economic benefit of this contribution is discussed in Chapter 7

- Honeybees may be able to sufficiently pollinate cotton flowers in a short period (10-15 d) when a high stocking rate of 16 colonies / ha is used. This may provide cotton growers with the opportunity to use non-residual but hazardous pesticides during flowering, yet take advantage of the contribution of honeybee pollination.
- Nectar gathering bees may play a significant role, and comparable to pollen gatherers, in cotton pollination. Although they may reject cotton pollen, which might reduce the amount brought to hives, this is unlikely to reduce their pollination efficacy.
- Non-*Apis* pollinators were rare, and their role in cotton pollination appears to be negligible.
- Gene flow from Bt cotton is likely to occur in the presence of high numbers of honeybees, and further studies of this important issue are required. The protocols for use of buffer zones around Bt cotton are likely to vary between different countries and regions, because of varying climate, geography and diversity and abundance of pollinators.

## CHAPTER 5

### THE ROLE OF POLLEN BEETLES IN COTTON POLLINATION, AND THEIR EFFECTS ON THE FORAGING BEHAVIOUR OF HONEYBEES

#### 5.1 INTRODUCTION

The beetles comprise the largest and most diverse order of arthropods on earth. They are important in most ecosystems, where they commonly have roles as phytophagous, oligophagous and insectivorous species. A number are pest species, some are biological control agents, and others are decomposers or pollinators.

The majority of beetles are not floral visitors; some flower-visiting beetles, as with other pollinating insects, are interested in pollen and nectar as a food source, but some prefer to eat the flowers, or other insects. Predatory beetles often hide within flowers, waiting for soft bodied flies to visit. For example ladybirds (Coccinellidae), visit flowers primarily to feed on small pests such as aphids, although they may also consume some nectar as a carbohydrate source. Beetles tend to visit large heavily-constructed flowers that are either flat or bowl-shaped to give them an easy place to land (Grant & Connell, 1979). Relatively large beetles can damage flowers, or the pollinating parts of flowers, especially when they feed on pollen with their large biting and chewing mouth parts (Young, 1986; Gottsberger, 1990; Sakai *et al.*, 1999). Beetles with smooth bodies are not effective pollinators (Steiner, 1998a), but those covered with fine hair (setae) can carry pollen between flowers.

Flowers produce nectar and/or pollen to attract birds, bats and insects to pollinate them. The frequencies of insect visits to flowers, and their foraging behaviour can vary. For example, honeybees visit flowers to collect nectar and/or pollen and, during each foraging trip, a bee will normally visit one flower species (Free *et al.*, 1960; Benedek & Nagy, 1996). Other insects, however, such as beetles, thrips (Thysanoptera) and some tephritid flies (Diptera: Tephritidae) live and breed in flowers (Jones & Jones, 1984;

Murawski, 1987; Kirk *et al.*, 1995; Steiner, 1998a; Zerega *et al.*, 2004). These insects have been reported as beneficial species because they pollinate the flowers (Kirk, 1984, 1988; Young, 1988; Momose *et al.*, 1998; Sakai, 2001; Zerega *et al.*, 2004; Blanche & Cunningham, 2005; Craig & Steven, 2006). They may also use flowers as a safe refuge and/or mating site (Young, 1986; Gottsberger, 1989a; Steiner, 1998a, b; Goldblatt *et al.*, 1998, Stevenson *et al.*, 1998; Garcia-Robledo *et al.*, 2004). However, destructive impacts have also been reported (Free & Williams, 1979; Kirk *et al.*, 1995; Goldblatt *et al.*, 1998; Dieringer *et al.*, 1999; Hansen, 2004; Leavitt & Roberson, 2006). Although the direct damage that such insects can do to flowers, and hence to seed yield, is well known in a wide range of plants (Jones & Jones, 1984), little is known about the indirect damage that they can do by deterring pollinators such as honeybees and bumble bees from visiting the flowers.

The presence of other flower visitors has been observed to influence the foraging behaviour and efficacy of pollinators. This may be because the pollinators may be avoiding predators or competitors, or because of reduced nectar and/or pollen. Dukas & Morse (2003) reported that the bumblebee, *Bombus ternarius* (Say), and the European honeybee avoided patches of milkweed, *Asclepias syriaca*, harbouring the crab spider, *Misumena vatia* (Clerck) (Araneae: Thomisidae), and Robertson & Maguire (2005) reported a similar result for a number of insects visiting slickspot peppergrass, *Lepidium papilliferum* L. (Brassicaceae). Kerner (1878), cited in Kirk *et al.* (1995) observed moths avoiding gentian *Gentiana* spp. (Gentianaceae) flowers that contained the staphylinid beetle *Omalius excavatum* Stephens. He also observed bumble bees avoiding gentian flowers that contained the nitidulid *Meligethes exillis*. Wyatt (1980) noted that nectar-robbing ants reduced pollination by the monarch and queen butterflies *Danaus plexippus* (L.) and *D. berenice* (Cramer) in *Asclepias curassavica* L. (Asclepiadaceae), and Murawski (1987) stated that butterflies, *Heliconius* sp. (Lepidoptera: Nymphalidae), learned to avoid pygmy melon, *Psiguria warscewiczii* (Cucurbitaceae), flowers containing tephritid fly larvae (*Blepharoneura* sp.).

Kirk *et al.* (1995) found that honeybee foragers visited only 7.5% of *Brassica napus* L. flowers containing the pollen beetle, *Meligethes aeneus* (F.), and that even simulated adult beetles (black spots on the petals) deterred nectar gatherers from landing. The avoidance of flowers may be of importance to beekeepers when they are widely infested with other insect species. Some Australian beekeepers believe that thrips repel honeybees from flowers (Anon, 1931), and Parks (1927) stated that honeybees did not work the flowers of *Prosopis* sp. (Fabaceae), in the USA, when thrips or beetles were in the flowers. During thrips outbreaks, the nectar production of flowers can be so reduced that bees starve (Anon, 1931; Evans, 1932). Although bees could be avoiding insects in the flowers, they may be responding simply to reduced amounts of nectar or pollen. Therefore, reduction in the number of pollinator visits could affect a plant's yield and fitness through reduced maternal progeny (via ovules) and/or reduced paternal progeny (via pollen). Such effects could occur at levels of infestation below those at which physical damage is apparent, and so could easily go unnoticed.

Small black nitidulids are abundant on cotton flowers in NSW, including Narrabri (per. obs. in 2005 and 2006 cotton seasons- see Chapters 2 and 4) and other parts of the Namoi Valley (Llewellyn & Fitt, 1996, Llewellyn *et al.*, 2007), Tamworth (Rhodes, 2002) and Bourke (Jones per. comm., 2006). As the contributions of these beetles to pollination of cotton flowers and their effects on the foraging behaviour of honeybees was unknown, I conducted investigations to elucidate these issues. Although pollen beetles were the most abundant visitors to cotton flowers, this does not necessarily mean that they were effective at transferring pollen to stigmas. In considering the relative contributions of honeybees and pollen beetles to the pollination of cotton, since wind does not play any role in pollination, it was important to consider their abundance and pollination effectiveness.

I considered estimates of abundance and efficacy of these two major flower visitors to compare their relative contribution to cotton pollination. In particular, I addressed the following questions:

- (1) Do the two major insect visitors (honeybees and pollen beetles) vary in their pollination efficacy (i.e. on cotton yield and quality), and if so, why?
- (2) How does beetle abundance vary during the flowering season, and what is the effect of varying beetle abundance on boll set?
- (3) Does presence of beetles deter bees from visiting cotton flowers?

## **5.2 MATERIALS AND METHODS**

### **5.2.1 Location**

Two experiments were conducted in fields of a commercial irrigated transgenic (Bollgard® II) Sicot 71BR cotton crop at the ACRI in Narrabri during the flowering season in 2006-07. The 18 ha trial field was divided into two plots, Plot 1 with 16 ha and Plot 2 (planted one month later than Plot 1) with 2 ha.

### **5.2.2 Abundance of pollen beetles**

An important first component of the biological studies of pollen beetles was their field population dynamics. These data may provide basic information on their role in the ecosystem, such as pollination efficacy and their influence on other pollinating insects. Because pollen beetles hid inside the corollas and could not be collected by D-vac or net-sweeping; beetle numbers were assessed by hand collecting flowers. More than 100 cotton flowers were collected together in sealable plastic bag. The flowers were brought to the laboratory, and the beetles were killed in a freezer (-18°C overnight) to facilitate counting. The number of beetles / flower was then determined. Data were taken weekly, from flowering commencement on 2 January 2007 to the end of the flowering season on 19 February 2007, to estimate the average number of beetles / flower and, accordingly, the density of pollen beetles during the season. To obtain uniform and reliable data, flowers were collected at the same time each day (12:30-13:00). At least four rows of cotton were used for their collection. To obtain a representative sample, flowers were randomly collected from the selected rows, with approximately one flower collected / metre of row. Because beetles generally remain in flowers during daylight, I assumed that sampling at midday was appropriate for assessing the relative abundance of the beetles.

For each observation time, I estimated the pollen beetle density (number of beetles / flower), and population (number of beetles / ha) using the following formula:

**Number of beetles/ ha = beetle density × flower density\***

\*Flower density = flowers / m × 10,000

### ***5.2.3 Foraging behaviour of pollen beetles***

Preliminary observations of the foraging behaviour of pollen beetles on cotton flowers and their diurnal activity during the cotton flowering season were documented. Samples of beetles were collected, placed in vials containing 70% ethanol and stored for later identification.

### ***5.2.4 Pollination efficacy of pollen beetles***

I defined pollinator effectiveness as the number of bolls set, boll weight and number of seeds per boll, after insect visitation to the flowers. To evaluate this parameter, I performed pollen beetle introduction experiments, using two techniques (1) caging cotton plants, and (2) bagging single cotton flowers. Cotton yield parameters from all treatments were compared.

#### ***5.2.4.1 Cage experiment***

This trial was conducted in Plot 2 at peak flowering (Figure 3.1), from 1 to 7 February 2007, to examine the contribution of pollen beetles to cotton pollination under Australian conditions in the presence of managed honeybees (at a stocking rate of 16 colonies / ha) and, possibly, wild bees and other pollinators. The middle row of the plot was selected to assess the pollination efficacy of these beetles; the row included 15 plots arranged in a completely randomized block design (RCBD). These were located in five blocks, with each block comprising one replicate of each of the three treatments. Each plot consisted of a single row of cotton, 3 m long, and plots were 10 m apart. There were approximately 30 plants in each plot, and all plants were of similar size. One day before the cages were erected, all flowers and bolls were removed from the plants within all plots. This was done because they had already been pollinated and would have confounded our treatment

effects. It also ensured that all pollen beetles in the plots were removed prior to commencement of the experiment. Treatments were:

*I. Caged plots: insect exclusion (Self-pollination)*

Beetles and other insects (mainly honeybees) were excluded by caging the plots throughout the investigation period. This treatment was regarded as the control.

*II. Caged plots with pollen beetles*

To evaluate the role of pollen beetles in cotton pollination; cotton plants were caged from 1 to 7 February 2007. During this period, 30 beetles were introduced to each cage on every second day, by collecting numerous freshly open cotton flowers from nearby plants, placing the flowers briefly in a plastic bag, and then releasing the beetles directly into the treatment plots. This ensured the presence of active beetles in this treatment.

*III. Uncaged plots (Insect pollination)*

Cotton flowers in similar sized plots to Treatments 1 and 2 were exposed to insects, including honeybees and pollen beetles.

Cages (tent-shaped 1.5 m high and 3 m long, with 2 mm white mesh) were erected on 31 January (18:00), and after 7 d (7 February 18:00), all cages were removed and all pollinated flowers were tagged. Each treatment was allocated a different colour tag so that bolls could be easily identified when they were hand-harvested on 13 April 2007; untagged bolls were neglected. Yield was determined by weighing plot samples at ACRI, ginning the cotton, and counting and weighing seeds to obtain an average seed weight. Other measurements of quality and quantity tests were also recorded (see 2.2.7.2). I statistically tested the significance of differences in the rate of boll set, yield and lint quality between treatments.

**5.2.4.2 Bagged flower experiment**

The result of pollen beetle presence on pollination was also assessed by comparing the yield of cotton by bagging individual flowers, instead of caging whole plants (Figure 5.1).



This was to avoid any effects of the experimental cages on cotton plant physiology which might have subsequently impacted on yield. Since cotton flowers open in early morning, bagging of flowers took place in very early morning (07:00-8:00), before they had opened, to prevent any prior insect visitation. Treatments were:

I. *Bagged flower without insects (Self-pollination)*

Flowers were isolated by placing over them a 20 × 40 cm mesh pollination bag, made at ACRI for cotton pollination experiments, to exclude beetles and other pollinating insects. This was regarded as the control treatment.

II. *Bagged flower with pollen beetles (Beetle cross-pollination)*

Flowers were initially bagged at 07:00 to prevent any insect visitation and two hours later (09:00); three pollen beetles collected directly from freshly opened flowers were released into each bagged flower.

III. *Highly beetle-infested flower*

This treatment was similar to Treatment 2, except that ten pollen beetles were released into each bagged flower. This was considered, based on previous observations, to be a very high beetle infestation.

IV. *Un-bagged flower (Insect cross-pollination)*

Flowers were exposed to pollen beetles and other insects, including honeybees.

Twenty randomly selected flowers were tagged in each treatment on each of five occasions: 29 and 31 January, and 5, 7 and 9 February 2007 (80 flowers / date, 400 flowers in total). Flowers in the bagged-flower treatments were bagged immediately after tagging. The bags were removed the following day.

All mature tagged bolls were collected on 13 April 2007, as previously described in 5.2.4.1. Quantitative and qualitative tests were undertaken at ACRI. I statistically tested

the significance of differences in the rate of boll set, yield and lint quality between treatments.

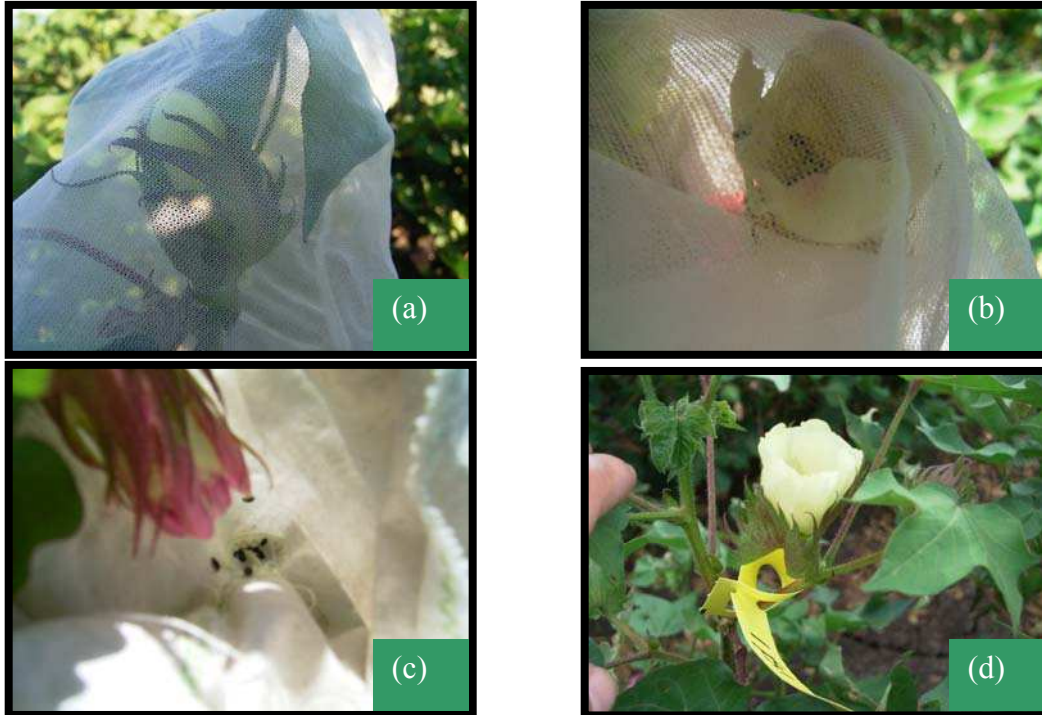

**Figure 5.1** Assessment of the pollination efficacy of pollen beetles by bagging cotton flowers with: a. no insects; b. 3 pollen beetles; c. 10 pollen beetles; d. unbagged (exposed to pollen beetles and honeybees).

### *5.2.5 Effects of pollen beetles on honeybee visits to cotton flowers*

An investigation to assess the effects of presence of pollen beetles in cotton flowers on honeybee visitation was conducted in January-February 2007. This was conducted in the same field and at the same time as described in Chapter 4 for the field pollination experiment (4.2.1).

Thirty-two honeybee colonies were placed adjacent to the cotton field (Plot 2) on 26 January 2007. Two rows, 60 and 80 m from the managed honeybee colonies, were chosen to determine the honeybee visitation rates. Each row comprised 15, 10 m-long subplots, which were 5 m apart. Observations of insect visitations were taken at 12:00 and 14:00

(to coincide with peak honeybee visitations) during the cotton flowering season on the 29 and 31 January, and 5, 7, 9, 12 and 14 February 2007. The methodology has been described in detail in 2.2.7.1. Every cotton flower observed to be visited by honeybee foragers was inspected carefully to confirm presence of beetles. The proportion of the flowers visited by honeybees which were occupied by pollen beetles was calculated.

### **5.2.6 Recording meteorological conditions during the investigation period**

As temperature and humidity are the major climatic factors influencing pollinator and plant biology (see Chapter 4.2.4), these data were collected at the field site, and have been presented in Chapter 4.

### **5.2.7 Statistical analyses**

Data were analyzed using ANOVA, General Linear Model, SPSS® for Windows™ Version 14 (SPSS Inc. 2007). Prior to analysis each variable was visually tested for normality using P-P plot and Levene's test was used to test the assumption of equality of error variance.

When significant differences were detected, Ryan's Q test was used to separate treatment means if data met the assumption of equality of variance and Dunnett's T3 test was used if the assumption of equality of variance was not met after appropriate transformation of data. In all cases, significance was accepted at the 0.05 level.

## **5.3 RESULTS**

The pollen beetle was identified as *Carpophilus aterrimus* Macleay by ACRI entomologists (Room, 1979). Adults are about 3-4 mm long, 1-2 mm wide and black. A number were observed mating within the flowers, although no larvae were observed.

### **5.3.1 Abundance of pollen beetles in the flowers**

Although the crop commenced flowering at the end of December, no pollen beetles were observed until the second week of January (Figure 5.2). The number of pollen beetles was estimated in the field in both Plots 1 and 2, which enabled observations of beetle

abundance in two overlapping cotton crops. Data showed that the beetle population increased dramatically. The mean numbers of beetles per cotton flower in Plot 1, at approximately weekly intervals from 2 January to 5 February 2007, were 0.00, 0.29, 0.68, 0.70, 1.23, and 4.11, whereas the mean numbers per flower at approximately weekly intervals from 15 January to 14 February in Plot 2 were 0.56, 0.67, 1.20, 4.09, 5.25, and 8.07 (Figure 5.2). The flowering pattern (mean number of flowers / m) in Plot 2 is also presented.

The estimated populations of pollen beetles were 476, 7000, 33948, 131520, 92925 and 73437 beetles / ha on 15, 23, 29 January and 5, 12 and 14 February 2007, respectively.

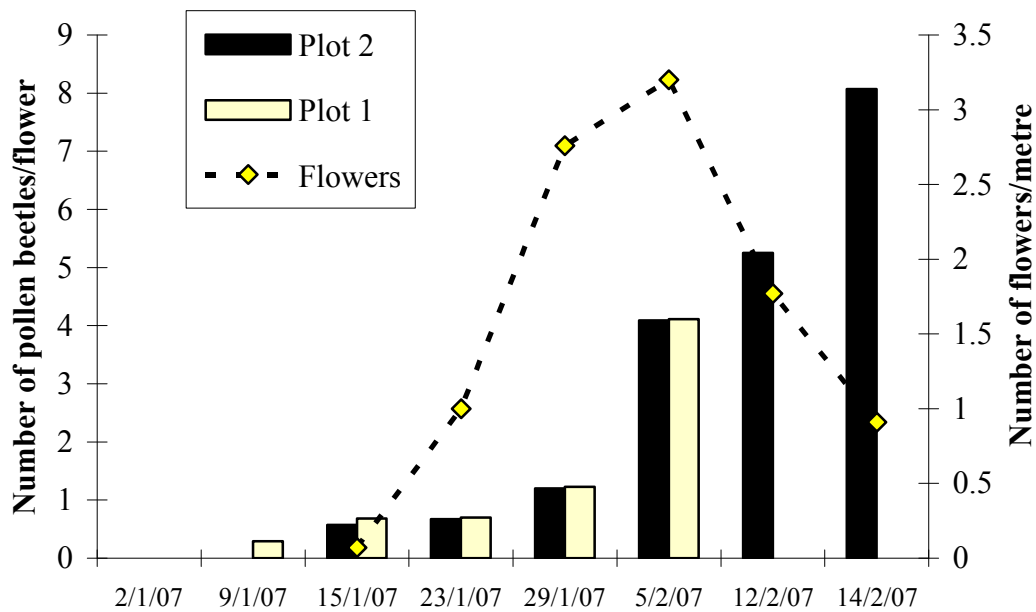

**Figure 5.2** Pollen beetle, *C. aterrimus*, abundance in Plot 1 from 2 January to 5 February and in Plot 2, from 15 January to 14 February 2007. The dotted line represents the average number of open flowers, in Plot 2.

### 5.3.2 Foraging behaviour of pollen beetles

Normally, *C. aterrimus* remained most of the day in flowers after entering them, usually shortly after they were fully opened, but occasionally, when morning temperatures were exceptionally high, when flowers had not or had only partially opened. They always

landed on flowers, and never on leaves. Beetles spent the daytime in the cotton flower, where they were observed climbing up the anthers to feed on pollen, thereby becoming dusted with pollen grains. Later, they usually remained at the base of the flower, where the nectaries are located, presumably feeding on nectar or perhaps resting. Occasionally, they were observed mating. Although cotton plants have extrafloral nectaries, the beetles were not seen working outside the flowers. Also, apparently to avoid exposure to the sunlight, beetles were observed to hide under the shade of petals. In the afternoon, the cotton flowers started to close. However, the beetles did not leave and stayed overnight in the flowers, or between the petals and the flower bracts. On the following morning, they dispersed from the wilted to freshly opened flowers. Although beetles were seen flying from flower to flower, because of their small size, their flying pattern and frequency of flight was not easy to determine.



**Figure 5.3 Cotton flower occupied by more than 20 pollen beetles, located on the anthers and close to floral nectaries.**

The number of beetles in flowers varied considerably, particularly early in the investigation. For example, some flowers were recorded with 3-6 beetles alongside

similar flowers with no beetles. In the later period of the flowering season, the number of beetles / flower increased dramatically, with commonly 20-30 individuals recorded (Figure 5.3). Such flowers were often visibly damaged (Figure 5.4), with a consequential reduction in boll set (Table 5.3).

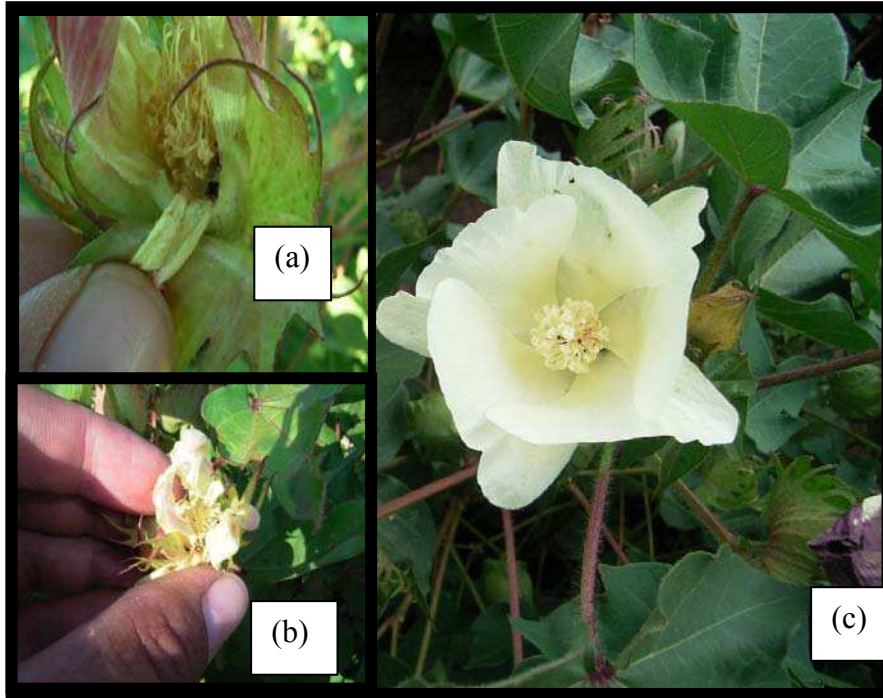

**Figure 5.4 Cotton flowers showing signs of damage by high numbers of occupying pollen beetles, (a) and (b) damaged flowers, (c) un-infested flower.**

### ***5.3.3 Pollination efficacy of pollen beetles***

Pollen beetles did not contribute to fruit set in cotton. Yield data from both cage and bag experiments were similar and showed that bolls from flowers exposed to honeybees and other insects, rather than those exposed to pollen beetles only, were the heaviest and contained the highest number of seeds.

#### ***5.3.3.1 Cage experiment***

Cotton yield data were compared between caged plots with and without beetles, and open plots. The presence of 30 pollen beetles in caged plots (viz. with 30 plants) did not contribute to pollination. All yield parameters in both caged treatments (with/out beetles)

did not differ significantly; the total number of bolls harvested / m ( $F_{2,8} = 8.186$ ,  $P = 0.829$ ), total weight of bolls / m ( $F_{2,8} = 15.014$ ,  $P = 0.750$ ), mean boll weight ( $F_{2,8} = 42.379$ ,  $P = 0.258$ ), total weight of seeds / m ( $F_{2,8} = 16.494$ ,  $P = 0.733$ ), number of seeds / m ( $F_{2,8} = 14.496$ ,  $P = 0.773$ ), mean number of seeds / boll ( $F_{2,8} = 43.174$ ,  $P = 0.208$ ), total weight of lint / m ( $F_{2,8} = 12.816$ ,  $P = 0.775$ ) and weight of lint / boll ( $F_{2,8} = 22.351$ ,  $P = 0.930$ ). However, yield parameters for both caged treatments were significantly less than for open plots with flowers exposed to honeybees and other insects, with respect to the total number of bolls harvested / m ( $F_{2,8} = 8.186$ ,  $P = 0.012$ ), total weight of bolls / m ( $F_{2,8} = 15.014$ ,  $P = 0.002$ ), mean weight of boll ( $F_{2,8} = 42.379$ ,  $P < 0.001$ ), total weight of seeds / m ( $F_{2,8} = 16.494$ ,  $P = 0.001$ ), number of seeds / m ( $F_{2,8} = 14.496$ ,  $P = 0.002$ ), mean number of seeds / boll ( $F_{2,8} = 43.174$ ,  $P < 0.001$ ), total weight of lint / m ( $F_{2,8} = 12.816$ ,  $P = 0.003$ ) and weight of lint / boll ( $F_{2,8} = 22.351$ ,  $P < 0.001$ ) (Table 5.1). However, there was no significant increase in mean weight of 100 seeds ( $F_{2,8} = 0.133$ ,  $P = 0.877$ ).

**Table 5.1 Effect of pollen beetles, *C. aterrimus*, on cotton yield parameters under caged (with/out beetles) and uncaged plants at ACRI, 2007.**

Measurement	Caged (Mean $\pm$ SE)		Uncaged (Mean $\pm$ SE)
	No insects	30 beetles	
Number of bolls / m	20.0 $\pm$ 4.9 <sup>b</sup>	18.5 $\pm$ 3.5 <sup>b</sup>	40.0 $\pm$ 4.5 <sup>a</sup>
Weight of bolls (g) / m	97.4 $\pm$ 26.4 <sup>b</sup>	85.7 $\pm$ 17.1 <sup>b</sup>	239.3 $\pm$ 24.6 <sup>a</sup>
Boll weight (g)	4.81 $\pm$ 0.14 <sup>b</sup>	4.58 $\pm$ 0.11 <sup>b</sup>	6.00 $\pm$ 0.10 <sup>a</sup>
Number of seeds/ m	492 $\pm$ 127 <sup>b</sup>	427 $\pm$ 80 <sup>b</sup>	1214 $\pm$ 138 <sup>a</sup>
Weight of seeds (g) / m	59.0 $\pm$ 16.5 <sup>b</sup>	51.7 $\pm$ 10.4 <sup>b</sup>	145.7 $\pm$ 13.4 <sup>a</sup>
Weight of 100 seeds (g)	11.87 $\pm$ 0.30 <sup>a</sup>	11.95 $\pm$ 0.30 <sup>a</sup>	12.09 $\pm$ 0.28 <sup>a</sup>
Number of seeds / boll	24.4 $\pm$ 0.3 <sup>b</sup>	23.1 $\pm$ 0.4 <sup>b</sup>	30.3 $\pm$ 0.7 <sup>a</sup>
Weight of lint (g) / m	38.3 $\pm$ 9.8 <sup>b</sup>	33.9 $\pm$ 6.7 <sup>b</sup>	93.6 $\pm$ 11.2 <sup>a</sup>
Weight of lint (g) / boll	1.80 $\pm$ 0.11 <sup>b</sup>	1.81 $\pm$ 0.5 <sup>b</sup>	2.28 $\pm$ 0.11 <sup>a</sup>

\* Means in the same row with the same letters are not significantly different at  $P < 0.05$

Pollen beetles in the caged plots did not significantly contribute to lint quality parameters such as length ( $F_{2,8} = 1.216$ ,  $P = 0.346$ ), uniformity ( $F_{2,8} = 0.664$ ,  $P = 0.541$ ), strength ( $F_{2,8} = 0.418$ ,  $P = 0.672$ ) and micronaire ( $F_{2,8} = 2.148$ ,  $P = 0.179$ ) (Table 5.2).

**Table 5.2 Effect of pollen beetles, *C. aterrimus*, on lint quality parameters (mean length, length uniformity, strength, and micronaire measured using HVI) for bolls collected from caged (with/out beetles) and uncaged cotton plants.**

Measurement	Caged (Mean $\pm$ SE)		Uncaged (Mean $\pm$ SE)
	No insects	30 beetles	
Length (mm)	1.18 $\pm$ 0.01	1.17 $\pm$ 0.01	1.19 $\pm$ 0.01
Uniformity (%)	84.7 $\pm$ 1.0	83.9 $\pm$ 0.7	85.1 $\pm$ 0.4
Strength (g / tex)	33.0 $\pm$ 0.9	33.9 $\pm$ 0.7	33.2 $\pm$ 0.2
Micronaire	5.0 $\pm$ 0.0	4.7 $\pm$ 0.1	5.1 $\pm$ 0.1

\* All values in the same row did not differ significantly at  $P < 0.05$

### 5.3.3.2 Bagged flower experiment

Because bolls of each treatment were incorrectly collected in one bag (i.e. no replicates), data from this trial were not statistically analyzed. However; there was a strong trend towards negative effects in all measured yield parameters with increasing numbers of beetles in flowers (Table 5.3). There were no obvious trends of low beetle numbers influencing quality parameters (Table 5.4). No bolls were produced from flowers occupied by more than ten beetles.



**Table 5.3 Effect of pollen beetles, *C. aterrimus*, on cotton yield parameters from bagged (with/out beetles) and unbagged cotton flowers at ACRI, 2007.**

Measurement (100 flowers)	Bagged with beetle number			Unbagged
	0	3	10	
Number of bolls	47	26	0	48
Weight of bolls (g)	225.9	121.0	0	262.3
Mean weight of boll (g)	4.80	4.65	0	5.46
Number of seeds	1207	640	0	1380
Weight of seeds (g)	135.1	72.0	0	156.8
Weight of 100 seeds (g)	11.26	11.28	0	11.36
Mean number of seeds / boll	25.68	24.62	0	28.75
Weight of lint (g)	90.8	49.0	0	105.5
Mean weight of lint (g) / boll	1.93	1.88	0	2.19

**Table 5.4 Effect of pollen beetles *C. aterrimus* on lint quality parameters (mean length, length uniformity, strength, and micronaire measured using HVI) for bolls collected from bagged (with/out beetles) and unbagged cotton flowers.**

Measurements (100 flowers)	Bagged with beetle number (Mean)		Unbagged (Mean)
	0	3	
Length (mm)	1.17	1.15	1.19
Uniformity (%)	85.3	84.1	82.9
Strength (g / tex)	32.8	33.1	34.1
Micronaire	5.2	5.3	5.3

#### **5.3.4 Effects of pollen beetles on honeybee visits to cotton flowers**

A total of 9864 cotton flowers were observed during the study period of 25 d. Out of the 338 flowers observed to be visited by honeybee foragers, 191 had no adult beetles, whereas the remaining 147 flowers were infested with beetles, with numbers ranging from one to more than 20 beetles / flower. As reported in 5.3.1, the number of beetles per flower increased during the study period. These observations appear to indicate that bees

preferred to visit flowers without beetles (Figures 5.5, 5.7, 5.8). However, because nectar-gathering and pollen-gathering bees behaved differently during their visits to beetle-infested flowers, I conducted more detailed observations, in which I compared food collection behaviour of individual bees.



**Figure 5.5** A honeybee forager landed on a petal, and inspecting the flower cautiously so as to avoid pollen beetles.



**Figure 5.6** Honeybee forager collecting floral nectar from outside a flower infested with *C. aterrimus*: this may be a form of avoidance behaviour.

### 5.3.4.1 The effect of pollen beetles on nectar-gathering bees

A total of 279 nectar-gathering bees were observed on cotton flowers. Of these, 136 (48.7%) visited cotton flowers occupied by beetles, while 143 visited un-infested flowers (Figure 5.7). However, the proportion of bees visiting beetle-occupied flowers was very low at the beginning of the investigation, and increased greatly as the investigation continued.

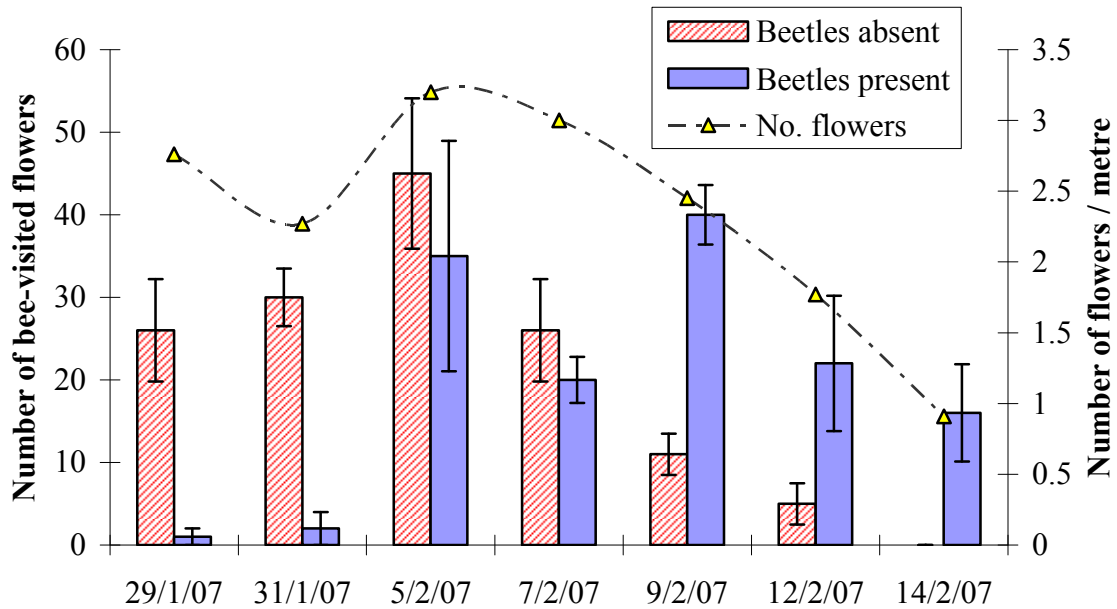

**Figure 5.7** The effect of *C. aterrimus* presence in flowers on the number of infloral visits by nectar-gathering bees, during the period 29 Jan to 14 Feb 2007.

Thus, the honeybee foragers preferred to visit un-infested flowers. However, it appears that with increasing pollen beetle density (Figure 5.2), the proportion of flowers observed to be infested by beetles (data not presented) increased throughout the investigation, so by the last observation (14/2/07), all flowers were occupied by beetles, and therefore bees were forced to visit beetle-infested flowers. The number (%) of bee-visited flowers occupied by beetles was 1 (3.5%) ( $F_{1,6} = 15.756$ ,  $P = 0.007$ ), 2 (6.6%) ( $F_{1,6} = 49.00$ ,  $P < 0.001$ ), 35 (43.7%) ( $F_{1,6} = 0.358$ ,  $P = 0.572$ ), 20 (43.4%) ( $F_{1,6} = 0.771$ ,  $P = 0.414$ ), 40 (78.4%) ( $F_{1,6} = 42.763$ ,  $P = 0.001$ ), 22 (81.4%) ( $F_{1,6} = 3.888$ ,  $P = 0.096$ ), and 16 (100%) ( $F_{1,6} = 7.385$ ,  $P = 0.035$ ), respectively, on the dates shown in Figure 5.5. The handling

time of foragers in beetle-infested flowers was observed to be shorter than in un-infested flowers.

#### 5.3.4.2 The effect of pollen beetles on pollen-gathering bees

Honeybee foragers preferred to collect nectar from cotton and rarely collected pollen. A total of only 53 pollen-gatherers were observed on cotton flowers throughout the investigation. Of these, 11 bees (18.6%) visited cotton flowers infested with pollen beetles, while 48 visited un-infested flowers (Figure 5.8).

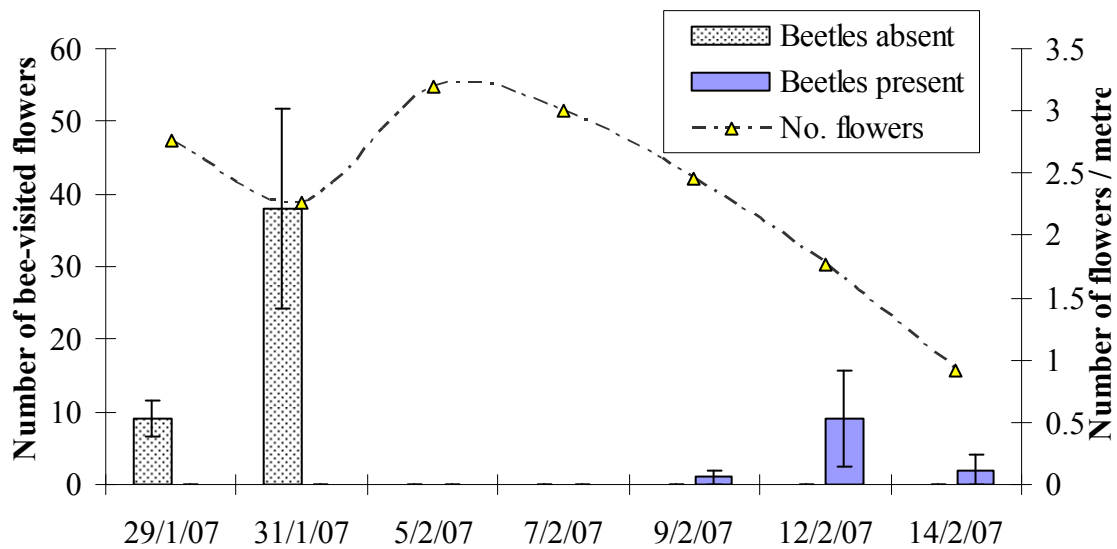

**Figure 5.8** The effect of *C. aterrimus* presence in flowers on the number of floral visits by pollen-gathering bees.

Thus, even more than the nectar-gatherers, pollen-gathering bees preferred to visit un-infested flowers. However, it appears that with increasing pollen beetle density, they were also forced to visit beetle-infested flowers. The number (%) of bee-visited flowers occupied by beetles was 9 (0%) ( $F_{1,6} = 12.789$ ,  $P = 0.012$ ), 38 (0%) ( $F_{1,6} = 7.681$ ,  $P = 0.032$ ), 0, 0, 1 (0%) ( $F_{1,6} = 1.000$ ,  $P = 0.356$ ), 9 (100%) ( $F_{1,6} = 1.855$ ,  $P = 0.222$ ) and 2 (100%) ( $F_{1,6} = 1.000$ ,  $P = 0.356$ ), respectively, on the dates indicated in Figure 5.7. As with the nectar-gatherers, handling time for beetle-infested flowers was observed to be shorter than for un-infested flowers.

In the days immediately after the honeybee colonies were introduced to the cotton field, some pollen-gathering bees were observed to fly around some flowers for 15-20 s before flying away. These flowers were subsequently found to be occupied by pollen beetles.

## **5.4 DISCUSSION**

### **5.4.1 Pollen beetle abundance in cotton flowers during the season**

*Carpophilus aterrimus* adults were commonly observed in cotton flowers, and cotton pollen grains were always present on their bodies. Their population, which was monitored in the trial field throughout the flowering period of the two overlapping crops, showed a dramatic increase in both number of flowers occupied by beetles and the mean number of beetles per flower. At the commencement of flowering of the first crop (late December) no beetles were recorded in flowers. By peak flowering (mid January) there was a mean of between 0.3-0.7 beetles / flower (476 to 33948 beetles / ha), and by late flowering (early February) this number had risen to 4.1 (131520 beetles / ha). By the time the second crop was in at late flowering (mid February) the mean number of beetles / flower reached 8.1 (73437 beetles / ha). While pollen beetle numbers were not recorded in my first field investigation (Chapter 2), a similar pattern of their build-up in flowers late in the season was noted.

While adult pollen beetles were seen frequently mating in flowers, no larvae were observed. This is not surprising, given cotton flowers are open for only one day and the wilted corolla commonly falls the day after flowering. The life cycle of this species is still unknown.

It should be noted that the first crop was developing at a similar time to most other commercial cotton crops in the district, and the second crop was regarded as “late-sown”. Thus, it is unlikely that flowers in commercial cotton crops would reach the maximum levels recorded in this investigation.

My findings are consistent with those of Llewellyn *et al.* (2007) who reported that pollen beetles built up over the flowering at Wee Waa (20 km from the current trial field site)

and were most numerous late in the season. They reported that most of these pollen beetles appeared in the cotton flowers over a short period of just 10-15 days, and suggested that they were probably immigrants from surrounding grasslands which were attracted to the crop later in flowering. It is likely that at this time, the pollen beetle populations have built up on other plants, and cotton has one of the few attractive flowers available.

#### ***5.4.2 Attractiveness of cotton flowers to pollen beetles***

Flowers commonly adapt their pollination syndrome; for example, wind-pollinated flowers produce higher numbers of pollen grains which are relatively light. Also, insect-pollinated flowers offer many rewards to attract their pollinators (i.e. nectar and/or pollen), through colour, morphology and fragrances. The attractiveness of cotton flowers to pollen beetles may be a result of one or a number of these factors.

Cotton flowers are bowl-shaped with yellow petals. Such a structure is common in many zygomorphic beetle-pollinated flowers (Dafni *et al.*, 1990), because the platform formed by the petals and anthers enables pollinators to easily enter the corolla. The pollen beetle, *Meligethes aeneus* (F.), is attracted to the colour yellow (Ruther & Thiemann, 1997; Blight & Smart, 1999), which may also be true for *C. aterrimus*. Steiner (1998b) found that flower colour in *Cryptostegia grandiflora* was sufficient to attract the monkey beetle, *Lepithrix sp.*, and similar results for other monkey beetle species (Picker & Midgley, 1999; Mayer *et al.*, 2006) demonstrate the importance of visual rather than olfactory cues for attraction of these beetles.

Cotton flowers may also provide nectar and/or pollen as rewards for pollen beetles. Although cotton produces nectar from both floral and extrafloral nectaries, no pollen beetles were observed to visit any extrafloral sites. Floral nectar may be utilised as a carbohydrate source for beetles. Floral nectaries are located at the bottom of flowers, which is where pollen beetles were commonly located. Beetles were also observed around anthers or feeding on pollen. Many authors have reported nitidulids feeding on pollen in flowers of the families Areaceae (Henderson *et al.*, 2000; Nunez *et al.*, 2005),

Araceae (Garcia-Robledo *et al.*, 2004) and Zamiaceae (Kono & Tobe, 2007). Cotton flowers produce prodigious amounts of pollen (Vaissiere, 1991b), which would constitute a valuable reward for *C. aterrimus*.

Nitidulids are attracted by fruity, spicy, or unpleasant odours (Kono & Tobe, 2007), such as those from buds and flowerings of oilseed rape (Ruther & Thiemann, 1997; Blight & Smart, 1999), and flowers of Annonaceae (Gottsberger, 1999), Arecaceae (Nunez *et al.*, 2005), Araceae (Garcia-Robledo *et al.*, 2004) and Proteaceae (Hembor & Bond, 2005). However, there is no evidence of an attractive odour being produced by cotton.

#### **5.4.3 Pollen beetle behaviour in cotton flowers**

During the flower sample collection (12:00) I observed that beetles were seldom located singly, but tended to aggregate (i.e. one flower may contain 4-6 beetles but with no beetles present in the neighbouring flower). This behaviour might be due to an aggregation or other pheromone released by these beetles, as mating behaviour was frequently observed in cotton flowers, but it might also be due to kairomones.

Sex pheromones and coattractants have been reported in the family Nitidulidae, particularly in the genus *Carpophilus* (dried fruit beetles), which are attracted to the combination of male pheromone and odors from damaged host fruit that likely emanate in part from yeast colonies on the fruit. Whole-wheat bread dough and seven compounds identified from the odor of bread dough synergize attraction of *C. lugubris* (Murray), *C. dimidiatus* (Fabricius), and *C. hemipterus* (L.) (Lin & Phelan, 1991; Phelan & Lin, 1991; Lin *et al.*, 1992; Bartelt *et al.*, 1994, 1995) and *C. davidsoni* (Dobson) to male pheromone (Bartelt & James, 1994). Compounds identified from host plants also synergize attraction of males and females to male pheromone in *C. hemipterus* (Bartelt *et al.*, 1992; Dowd & Bartelt, 1991) and *C. obsoletus* (Erichson) (Petroski *et al.*, 1994).

High aggregation in flowers by the dynastid, *Cyclocephala atricapilla* (Mannerheim), has been reported by Steiner (1994) who suggested that the drive to find mates can be as strong as that to find food; but in most cases, both activities occur on the same flower and

often at the same time. However, Gibernau *et al.* (1999) suggested that a related species, *C. colasi* (Endrödi), is not likely to depend on chemical information such as pheromones to localize conspecifics but, rather, rely on stimuli produced by the inflorescences in order to meet mating partners. Because the biology of *C. aterrimus* has not been studied, it remains to be determined whether pheromones or kairomones play a part in aggregation in this species.

#### ***5.4.4 Pollination efficacy of pollen beetle***

In the current study, both experiments (caging and bagging) demonstrated that pollen beetles did not contribute to cross-pollination in cotton. Flowers that were accessible to honeybees and pollen beetles had a significantly higher boll set and weight, number of seeds per boll, lint yield and improved lint quality.

While pollination of cotton by honeybees and other hymenoptera has been reported, there are no accounts of beetle pollination, although Moffett (1983) reported the abundance of two beetles *Collops vittatus* (Say) (Melyridae), and *Conotelus mexicanus* Murray (Nitidulidae), in cotton flowers and suggested they may contribute to pollination. It might be expected that bees have a higher potential to contribute to cross-pollination than do pollen beetles because they carry greater pollen loads, and they move more frequently between flowers, which are open and available for pollination for only one day.

A comparison of the morphology of insects is also a useful indicator of their efficacy as pollinators. For example, while honeybees are medium-large insects with their body covered with branched hairs and corbiculae on their hind legs for storing pollen, pollen beetles are much smaller with smooth, glabrous bodies. Similar reports have been made on beetle morphology and pollination efficacy, where pollen carryover was higher in large beetles and/or those with hairy bodies. These were reported to be adequate pollinators of certain plants (Steiner, 1998a). Lippok *et al.* (2000) reported that long-horned leaf beetles, *Donacia pisatrix*, carried copious amounts of pollen, and were effective pollinators of *Nuophar ozarkana* and *N. advena* (Nymphaeaceae).



However, the contribution of flower visitors to pollination cannot be measured only by their visitation frequency (Schemske & Horvitz, 1984), and the amount of body pollen is not always a reliable index of their ability to affect fruit set (Inouye *et al.*, 1994). Clearly, fruit set and yield parameters are the ultimate testament to effective pollination. There were major differences in foraging activity between *C. aterrimus* and *A. mellifera*. Daily observations of cotton flowers from 08:00-18:00 indicated they differed in the frequency, the duration of visits, foraging behaviour and likely pollen transfer between cotton flowers.

The honeybees visited cotton flowers from the early morning, with visits peaking from 12:00-14:00 until 15:00-16:00, with rapidly declining visits coinciding with changes in flower colour (see Chapter 4). Honeybee foragers prefer to collect nectar, however, their body structure (i.e. hairy body) and foraging behaviour (i.e. species constancy, visitation frequency, pollen collection) might result in them transporting more pollen grains which are consequently deposited on stigma (see more details in Chapter 4). Pollen beetles enter cotton flowers in the early morning, but they move less frequently, often remaining in one flower all day (see 5.4.3). They also conduct other activities in flowers, such as eating and mating.

The timing of appearance of pollen beetles also suggests they are unlikely to be major contributors to insect vectored pollen dispersal in cotton. The first cotton flowers produce the heaviest bolls and are therefore regarded as the most important (Mensah per. com., 2005). During this period, beetles were not observed, although honeybees were. This late appearance is consistent with the findings of Llewellyn *et al.* (2007).

#### ***5.4.5 Detrimental effects of pollen beetles***

Bagged flowers into which three beetles had been introduced had lower boll set than flowers bagged without beetles, while unbagged flowers which were accessible to honeybees and other insects had the highest boll set, with the highest yield parameters. In the treatment in which single flowers were bagged with ten pollen beetles none of the 100 treated flowers produced a boll, indicating that a high population of beetles damages the

floral sexual parts and prevents fruit set. Beetles spent their time in flowers, feeding, mating, and walking around the stamens and, sometimes, on the stigmas. Their presence in large numbers is therefore likely to dislodge more ungerminated pollen from stigmas than is deposited (Gori, 1983), or the beetles' waste products may accumulate that could reduce pollination germination and thereby cause reduced fruit set (Young, 1988).

Observation of flowers naturally infested with high numbers of pollen beetles, as well as those exposed to ten beetles in the bagged experiment showed that beetles physically damaged floral structures. I observed small holes on petals that appeared to be associated with insect chewing, and the only insect present in these flowers was pollen beetle. In addition, flowers which hosted high numbers of beetles appeared ragged and shrivelled earlier in the day than other, normal flowers. Apart from the direct damage they might have done, they rendered the flowers much less attractive to other pollinators.

Other beetles have been reported to damage flowers, including special nutritive tissues (Beach, 1982; Gottsberger, 1989a; 1990), the apical parts of the petals (Sakai *et al.*, 1999; Dieringer *et al.*, 1999), anthers (Wafa & Ibrahim, 1959; Goldblatt *et al.*, 1998), staminodia (Young, 1986), or stigmas (Gibernau *et al.*, 1999; Sakai *et al.*, 1999). Búrquez *et al.* (1987) found a reduction in fruit set resulted from the increased exposure of *Astrocaryum mexicanum* inflorescences to scarab beetles, and Prance & Arias (1975) reported that flowers of *Victoria amazonica* produced less seeds in the presence of beetles. Young (1988) reported that while *Erioscelis sp.* was the most important pollinator of *Dieffenbachia longispatha*, fruit set decreased when the number of beetles per flower exceeded four as they remained on the male flowers eating and chewed the spathe tissue. Sakai *et al.* (1999), similarly, reported that chrysomelids and curculionids when present in high numbers contributed to pollination of *Shorea parvifolia*, even though they damaged apical petal fringes of most flowers and many stigmas, but not ovaries. Thus, insects such as beetles may be pollinators at low density, but detrimental at high populations, due to their cumulative floral damage (Young, 1988). This appears not to be the case for *C. aterrimus*.

While I demonstrated low fruit set with high pollen beetle densities, pragmatically, this situation is unlikely to occur naturally in the field until later in the cropping cycle. Therefore, pollen beetles would pose a more serious threat to late sown crops.

#### **5.4.6 Deterrence of honeybees by pollen beetles**

In the current study, honeybees visiting cotton flowers during the first half of the flowering season, showed a preference for flowers not occupied by pollen beetles. This was particularly obvious for nectar gatherers. However, later in the season when most flowers were occupied by beetles, minimizing choice for foraging bees, they did visit infested flowers.

However, when bees did visit occupied cotton flowers, they shortened the length of their visits (reducing handling time), apparently to avoid direct contact with the beetles. This phenomenon of deterring bees is likely to be very important in pollination or honey production. These findings are consistent with results of Kirk *et al.* (1995) who reported that the nitidulid, *Meligethes aeneus*, deterred honeybees from *Brassica napus* flowers. They found that out of 107 flowers visited by honeybees, only eight contained beetles.

The simplest explanation of why honeybees avoided flowers containing pollen beetles is that they had learned to respond visually to flowers without beetles. Flowers with visible adult beetles would have been avoided, simply because they differed from their learned flower image. Kirk *et al.* (1995), for example, reported that bees consistently avoided flowers containing pollen beetles or flowers with markings to simulate adult beetles. Murawski (1987) reported that pollinators such as butterflies can even learn the positions of infested flowers on a given day and avoid revisiting them. Such visual cues may have occurred in my investigations, as I observed a number of bees closely approaching flowers, or landing on flower bracts or petals, and not entering the flower before flying away. In addition, it may also partially explain my previously reported observations (Chapter 2) that bees frequently collected floral nectar from outside the cotton flowers, sitting between the bracts and petals, without entering them.

A second explanation is that there was a learned association by honeybees between presence of adult beetles in a flower and less available nectar, because the beetles may have fed on nectar themselves. This would be consistent with my observation that the honeybee handling time was shorter in infested flowers. Earlier in the season, bees might have avoided occupied flowers because of this learned association between beetles and low nectar availability. Alternatively, if bees avoided flowers with beetles in them for some other reason, flowers with beetles might actually accumulate more nectar because bees visit them less often. Kirk *et al.* (1995) found that floral nectar was slightly higher in *Brassica napus* flowers with adult *Meligethes aeneus*, but that flowers with larvae had significantly less nectar and with lower sugar content. In the case of *C. aterrimus* in cotton, this latter situation is unlikely to arise, because cotton flowers are only open for one day, and no larvae were observed in any flower.

## 5.5 CONCLUSIONS

- This is the first study which has investigated the role of pollen beetles in cotton pollination. My results should lead to future investigations on this previously neglected insect species.
- Pollen beetles did not contribute positively to cotton pollination, even at low densities.
- Cotton flowers may not set fruit when they have high numbers of pollen beetles. This may be because of interference with pollination, or direct feeding damage.
- Honeybees preferred to visit cotton flowers which had no beetles, and may reject flowers occupied by beetles if they have a choice. In addition, honeybees spent less time in flowers occupied by pollen beetles than in uninfested flowers.
- My study is one of a growing number to find a decrease in pollinator visits in response to arthropod occupation of flowers, suggesting that this phenomenon may be more widespread than has been previously recognized.

## CHAPTER 6

### ASSESSMENT OF TOXICITY OF FIPRONIL AND ITS RESIDUES TO HONEYBEES

#### 6.1 INTRODUCTION

For the past 20 years, the effects of pesticides on beneficial arthropods have been the subject of an increasing number of studies, and the potential effects have been reviewed several times (Haynes, 1988; Croft, 1990; Thompson, 2003; Cox, 2005; Desneux *et al.*, 2007). Two groups of organisms, natural enemies and pollinators, have received the most attention in this regard because of their value in integrated pest management (IPM) (Van Driesche & Bellows, 1996) and pollination processes (Richards, 1993; Barnett *et al.*, 2007).

The poisoning of honeybees by insecticides is a major problem affecting the use of bees for honey production and crop pollination (Atkins *et al.*, 1972; Johansen, 1977, 1977; Weaver, 1978; Moffett *et al.*, 1978b, 1979a; Stoner *et al.*, 1981; Johansen *et al.*, 1983). The detrimental effect of pesticides on honeybees depends on the toxicity of the material, the number and method of applications, time of day, weather conditions, and the type of food being collected (nectar or pollen) (Salman *et al.*, 1983; Hanny *et al.*, 1983; Waller *et al.*, 1988; Robertson & Rhodes, 1992; Estes *et al.*, 1992; Devillers *et al.*, 2003).

As discussed in Chapter 1, cotton has historically been the crop with the highest use of pesticides. However, with the introduction of transgenic Bt cotton (see Chapters 1, 4), it was anticipated the level of pesticide use would be significantly reduced (Perlak *et al.*, 2001; Qaim, 2003; Fitt, 2004), possibly to the extent that it might be safe to honeybees. However, infestations of some non-lepidopterous pests have increased in Bt cotton, probably due to reduced use of broad spectrum pesticides to control *Helicoverpa* spp. (Fitt, 2000). In particular, sucking insects have become an increasing problem in the USA (Greenplate *et al.*, 2001) and Australia (Ward, 2005; Mensah, per. com., 2006), In

Australia the green mirid, *Creontiades dilutus*, feeds on small squares, flowers and young bolls, causing abscission (Pyke & Brown, 1996; Ward, 2002; Whitehouse *et al.*, 2007).

The most commonly used insecticide against green mirid is fipronil, 5-amino-1-[2,6-dichloro-4-(trifluoromethyl) phenyl]-4-[(1-R,S) (trifluoromethyl) sulfinyl]-1H-pyrazole-3-carbonitrile (Figure 6.1), a member of the relatively new phenylpyrazole insecticide class (Cox, 2005), and has a broad-spectrum with both contact and stomach action. Fipronil is effective at low field application rates against insects that are resistant to other pesticides such as pyrethroids, organophosphates and carbamates (Bobe *et al.*, 1997). Since 2003, fipronil has been used more than twice as frequently in Australian Bt cotton than in conventional cotton (Doyle *et al.*, 2005).

Fipronil is highly toxic to honeybees, and is classified as a category 2 insecticide against them (Devillers *et al.*, 2003; Anon, 2006b), meaning it should only be applied during late evening after bees have stopped foraging. The current manufacturers' label instructions in Australia recommend a 28 d time interval between spraying and introduction of managed honeybees (Anon, 2006a).

This high toxicity was confirmed by my observations in field trials in 2004-5, when trials had to be relocated from a commercial cotton field because of high bee mortality due to aerial application of fipronil, and in 2005-6, when high bee mortality was recorded because of fipronil applications to an experimental cotton crop in a nearby field at ACRI. This forced my trials to be terminated. In the latter case, after fipronil was applied on January 10 2006, there was a sharp decline in bee visitation rate in cotton to a level substantially below that recorded in all subsequent investigations.

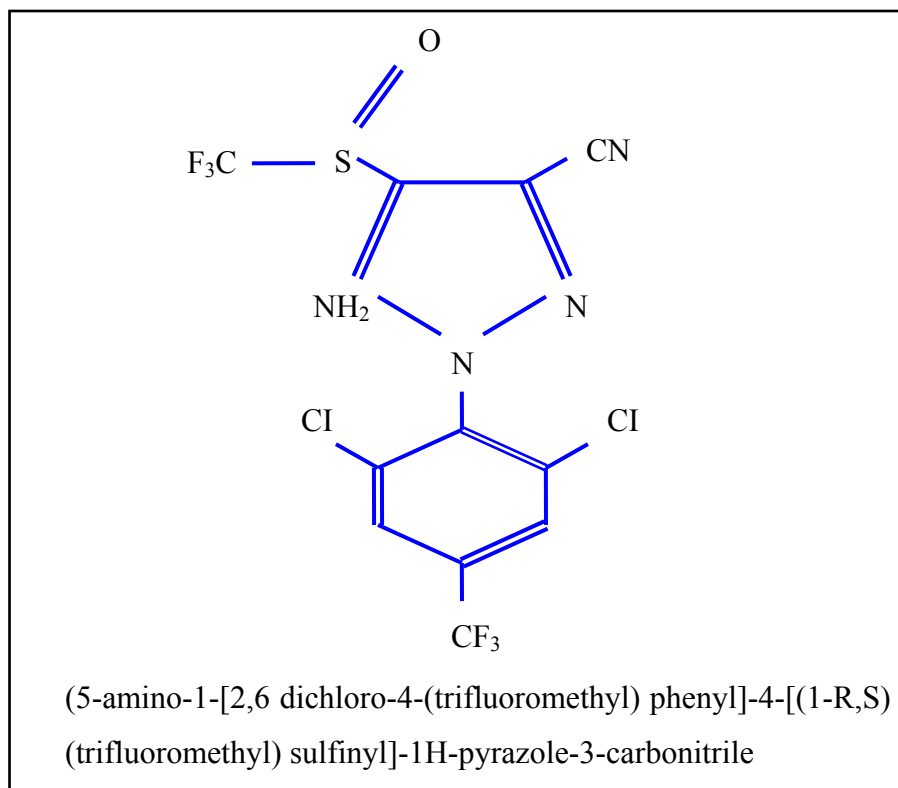

**Figure 6.1 Structure of fipronil** [Source: Cox (2005)]

Fipronil has a mode of action different from many common insecticides. In insects, it disrupts the nerves in the brain and central nerve cord by interfering with the ability of these nerve cells to transmit nerve impulses, resulting in uncontrolled activity, leading to death (Tingle *et al.*, 2003; Kadar & Faucon, 2006; Gunasekara *et al.*, 2007). When fipronil is exposed to light it degrades to produce a number of metabolites, one of which, fipronil-desulfinyl, is extremely stable and more toxic than fipronil itself (Tingle *et al.*, 2003; Gunasekara *et al.*, 2007).

The objectives of the work reported in this chapter were to investigate the toxicity of fipronil under laboratory conditions and in pot trials, in an attempt to explain field observations on high bee mortality. This chapter presents outcomes from observations and experiments conducted to find more definitive answers on:

- (1) The toxic effects of fipronil (topical, oral and contact with fresh residues) on honeybees.

- (2) The hazards posed to honeybees by different fipronil concentrations and exposure times.
- (3) The toxicity of aged fipronil residues on cotton foliage to honeybees.
- (4) How fipronil applications might be timed on flowering cotton where honeybees are foraging.

## **6.2 MATERIALS AND METHODS**

### **6.2.1 Honeybee samples**

Bees were sampled from the University of Western Sydney (UWS) apiary. Marked newly emerged worker bees have been successfully used to study age-related task performance (Winston & Punnett, 1982; Kolmes, 1985; Kolmes & Winston, 1986). In this study all bees used in the bioassay were the same age. This was achieved by taking a frame of sealed brood from the bee hive, placing it in a one-frame wire-cage and putting it into an incubator (Model TEI-100G, Thermoline Scientific, Smithfield NSW, 2164) at  $33 \pm 0.25^\circ\text{C}$ , and  $40 \pm 10\%$  RH). The following day all emerged bees (viz. 1 day-old) were marked by using non-toxic pilot-paint (uni POSCA, Mitsubishi Co. Ltd., Japan) on the dorsal side of their prothorax. For insecticide topical application trials, which were applied to the thorax, bees were marked on their abdomen. After marking, bees (400-600) were collected singly by forceps and transferred into three small ( $4 \times 6 \times 10$  cm) wire-mesh cages. The 1 cm exit in the cages was sealed with bee candy and set over the top of brood nest frames from their original hive, with the cage screen separating the marked bees from the bees below. This enabled the marked bees to receive sufficient odors from the bee colony so that they would not be attacked when they moved into the hive after the candy was consumed. After 6 d, all marked bees were re-collected by forceps, placed into the same small wire-mesh cages and transferred to the laboratory for the bioassay investigations.

### **6.2.2 Bioassay techniques**

Fipronil (Regent<sup>®</sup>200SC, Nufarm Australia Limited, Laverton North, Victoria 3026), containing 200 g / L fipronil, was used for the bioassays.



### **6.2.2.1 Topical acute toxicity of fipronil to honeybees**

To evaluate the acute topical toxicity of fipronil, a 1.0% (w/v) stock solution from the formulated product was prepared as follows: 1.0 g of Regent<sup>®</sup>200SC, was dissolved in 100 ml absolute alcohol [ $2.0 \times 10^3$  ppm active ingredient (a.i.)]. This was used to prepare further serial dilutions of 3.2, 2.6, 2.4, 2.0, 1.6, and 1.0 ppm a.i. using the same diluent. This procedure was repeated three times in order to obtain three true treatment replicates. Preliminary range-finding tests were conducted to determine the approximate LC<sub>50</sub> for honeybees. A small wire-mesh cage with seven-day old worker bees (collected as previously described) was placed into a 20 × 40 cm plastic bag then anaesthetized using medical grade carbon dioxide for 1 min to facilitate handling and treatment. Batches of 51 bees were randomly selected for treatment with one of the prepared concentrations. These bees were separately grouped into three sub-batches of 17, and each sub-batch was treated with one of the three replicate insecticide solutions.

For each bee, 1.0 µL of solution was drawn into the tip and gently dispensed on the middle of the dorsal side of its pronotum by using a precision hand micro-applicator PAX 100-3 (Burkard Scientific, PO Box 55 Uxbridge Middx, UB8 2RT, UK) with disposable tips. The control group was treated with 1.0 µL of absolute alcohol only. After treatment, the sub-batches of 17 bees were kept separately in 50 mL Schott glass vials and placed on the laboratory bench. Vials were covered with muslin netting supported with a rubber band. Food was provided as a piece of bee-candy (approximately 1.0 g), placed outside the vial on the muslin. All treated vials were retained under laboratory conditions ( $25 \pm 2$  °C, 50-70% RH). Observations of the mortality were recorded 24 h after treatment. Obviously healthy, active bees were counted as alive; all others were deemed dead by the absence of appendage movement.

Once the mortality data were collected, the LC<sub>50</sub> was determined (see Statistical Analysis, 6.2.4) from which LD<sub>50</sub> was calculated (e.g.  $LC_{50} \times V (1 \mu L) = 3.2 \times 10^{-3} = 0.0032 \mu g \text{ a.i. / bee}$ ). The assessment of the toxicity of fipronil for honeybees was then determined on the basis of the classification: Non-toxic, LD<sub>50</sub> > 100 ppm; Slightly toxic, LD<sub>50</sub> 100-11 ppm;

Moderately toxic, LD<sub>50</sub> 10.99-2.0 ppm; and Highly toxic, LD<sub>50</sub> < 2.0 ppm (Johansen, 1979; Anon, 2005b).

#### **6.2.2.2 Oral acute toxicity of fipronil to honeybees**

To evaluate the oral toxicity (stomach poisoning effect) of fipronil, a 50% honey syrup was prepared by mixing 50 g of honey with 50 mL distilled water (1:1 w/v) in a Ratek platform mixer (Model OM6, Ratek Instrument Pty Ltd, Boronia 3351, Victoria, Australia) for 30 min. A 1.0 g aliquot of Regent<sup>®</sup>200SC was suspended in 100 mL honey syrup in a volumetric flask to prepare a  $2.0 \times 10^3$  ppm a.i. (w/v) homogenous stock solution. This stock solution was used to prepare further serial dilutions 1.0, 0.8, 0.6, 0.4, 0.1 a.i. using the same solution. This procedure was repeated four times in order to obtain four true treatment replicates. Preliminary range-finding tests were conducted to determine the approximate LC<sub>50</sub> for honeybees, and also to ensure bees fed freely on treated honey syrup (to determine there was no repellency, and, thus, no restricted feeding). In addition, several preliminary experiments were conducted to develop the most suitable method for feeding bees with this syrup, using honey, honey solution, and honey solution in a Parafilm<sup>™</sup> (Pechiney Plastic Packaging Chicago Il.) cell. The most successful feeding station was the Parafilm<sup>™</sup> cell, which was subsequently used in all oral toxicity bioassays. The cell was set up as follows: 1 mL of the appropriate concentration syrup was poured onto a  $3.5 \times 3.5$  cm sheet of Parafilm<sup>™</sup>; which was then used as the lid of a small plastic 50 mm diameter Petri dish (Falcon<sup>®</sup>, Becton Dickinson, Franklin Lakes, NJ, USA), with the syrup located on the inside of the Petri dish. The remaining edges of the Parafilm were stretched to produce a seal on the base of the dish, thereby forming a single transportable unit. The Parafilm cell was perforated with an entomological pin to produce five holes around the location of the honey solution, to enable the bees to reach the honey solution with their mouth parts without contaminating their bodies. The cell was then gently placed with forceps in the base of a 200 mL Pyrex beaker.

Seven-day old worker bees were starved for 4 h prior to commencement of the bioassay, to ensure that they were uniform with regard to feeding, and to increase their

consumption of the honey syrup (Anon, 1998). The control group was provided with honey syrup only. The feeding of accurately measured doses of insecticide to individual bees is time-consuming and calls for a deal of equipment (Glynne & Connell, 1954), so Stevenson (1968) used a simplified group-feeding technique and obtained reliable results. I also used a group of 15 bees as a replicate. These were randomly selected and anaesthetized as described previously, then transferred to each concentration treatment Pyrex beaker. The beaker was then covered with muslin netting, supported with a rubber band. There were four replicates of each fipronil concentration. Observations on bee mortality were recorded 24 h after release, as described previously.

### ***6.2.2.3 Bioassays of fipronil residues***

Fresh and differently aged residues of fipronil were evaluated to determine hazardous doses to honeybee workers, time after exposure to cause mortality, and the exposure time to residues required to cause mortality.

#### ***a) Assessment of residual toxicity under laboratory conditions:***

##### ***I. Preliminary investigation- Estimating hazardous doses of fresh fipronil residues to honeybees***

To evaluate the residual toxicity of fipronil, 1.0 g of Regent<sup>®</sup>200SC was dissolved in 100 mL acetone in a volumetric flask to prepare a  $2.0 \times 10^3$  ppm a.i. (w/v) homogenous stock solution. This stock solution was used to prepare further serial dilutions of 0.1, 1, 10 ppm a.i., using the same diluent. A 1 mL aliquot from each concentration was poured in a 50 mL Schott multipurpose vial which was then rolled continuously over on a bench until complete dryness. In control treatment vials, 1 mL of acetone only was used. All treated vials were left for 1 h to ensure that absolute dryness had occurred. Ten bees were randomly selected and anaesthetized as described previously, then transferred to each treated vial. As the bees walked on the surface of treated vials, they contaminated themselves with the pesticide. Bees were fed as previously described in 6.2.2.1. There were two replicates of each fipronil concentration, except 10 ppm. Observations on mortality were recorded on an hourly basis, as described previously. The effects of the

different fipronil doses on bee mortality were assessed against the lapsed time after their release into the vials.

## **II. *Assessing effect of exposure time to fresh fipronil residues on honeybee mortality***

A stock solution of 0.25% Regent<sup>®</sup>200SC was prepared by dissolving 0.0625 g in 25 mL acetone in a 25-mL volumetric flask (i.e. 0.0125 a.i.) (w/v). A 1 mL aliquot of the diluted insecticide was poured into a 50 mL Schott multipurpose vial (inner surface area 59.1 cm<sup>2</sup>) which was rolled over on the bench until dryness. This gave a dose of  $8.4 \times 10^{-3}$  µg a.i. / cm<sup>2</sup>. This procedure was repeated five times in order to obtain five true treatment replicates. In control treatment vials, 1 mL of acetone only was used. All treated vials were left overnight. Twelve bees were randomly selected and anaesthetized with medical grade carbon dioxide, as previously described. Anaesthetized batches of bees were transferred to clean recovery vials, labeled with the required treatment. After the bees had recovered and returned to their normal activity, each vial was gently hand tapped to cause the bees to move to its bottom. Bees were transferred to the treated vial by placing their open ends together, turning them vertically so that the treated vial was bottom-most, and gently tapping the clean vial. Immediately after the bees had been transferred, the vial was covered with muslin netting, which was fixed in place with a rubber band. Each batch of bees was left inside the treated vial for the required exposure time before their transferal back to the original, clean vial. This transfer was undertaken as previously described.

Batches of bees were exposed to one of the following time periods: 1, 10, 20 or 40 min. An initial trial had indicated that these exposure times covered the full range of observable toxic effects in bees exposed to field concentrations of fipronil. As the bees walked on the surface of the treated vials, they contaminated themselves with the pesticide. After completing their exposure period, bees were immediately transferred to clean vials and provided with 1.0 g bee-candy on top of the muslin netting covering the vial, to avoid contaminating it with fipronil. Observations on mortality were recorded at 1.5 h intervals up to 24 h after initial exposure, as described previously.

### **III. *Assessment of residual toxicity of fipronil deposits to honeybees***

The same procedure described in II above was used to determine the residual activity of fipronil, 8, 14 and 28 d after the vials were treated.

#### **b) *Toxicity to honeybees of fipronil residues on cotton foliage exposed to normal weather conditions***

Fifty, transgenic Bt (Bollgard II® Sicut 71BR) cotton plants were sown on 5 November 2007 in 8 L plastic pots containing composted sawdust-based general open potting mix (Debco Pty Ltd, Vineyard 2765, NSW) and fertilized with an initial application of controlled-release complete fertilizer (Osmocote 3-4 month, Scotts Australia Pty Ltd, Baulkham Hills 2153, NSW) and pelletized poultry manure (Dynamic Lifter, Yates Australia, Padstow, NSW 2211). A soluble complete fertilizer, Thrive Professional (Yates Australia, Padstow 2211, NSW), was applied fortnightly at the recommended rate of 20 g / 10 L. Pots were watered individually, using micro-drippers via an irrigation system connected to a solenoid. Plants were maintained in a pesticide-free area in a greenhouse. They were regularly inspected for insect infestations, and caterpillar which was detected on plants was removed by hand.

After two months, plants were approximately 1 m high with their first floral buds (squares). Eighteen plants of uniform size and development were selected, and randomly allocated to the insecticide treatments. After labeling, they were transferred outside the greenhouse for application of the insecticide treatments. After application, plants were placed in a mesh house (2 mm - to prevent entry of insect pests and honeybees) on a wire mesh bench, 4 m under clear polyethylene greenhouse sheeting (to protect them from heavy rain). After the preliminary trials to determine the most appropriate method and rate of application of the treatments to the plants, plants were thoroughly and uniformly sprayed with the appropriate treatment, using a 450 mL pressurized Plaspak sprayer (Plaspak Co., Jannali 2226, NSW) at the rate 4.2 mL / plant. Six replicate plants were used for each of the following treatments:

- (1) Full recommended rate of Regent®200SC (125 mL / ha)

- (2) Half of the recommended rate of Regent<sup>®</sup>200SC (625 mL / ha)
- (3) Control (water only)

Calculations of rates were based on the recommended field full rate (125 mL / ha) (Farrell, 2007) and normal field plant density (10 plants / m); thus at this rate, each cotton plant would received  $125 \times 10^{-5}$  g of Regent<sup>®</sup>200SC. Accordingly, a stock solution of 0.03% was prepared by dissolving 0.3 g of Regent<sup>®</sup>200SC in a 1.0 L of distilled water. Each plant was sprayed with 4.2 mL of the insecticide solution. Half rate solutions were similarly prepared and applied.

After treatment, the cotton plants were left outside in separate treatment batches for 2 h to ensure foliage dryness, before they were transferred to the mesh house. Watering was provided to the pots, avoiding the plant foliage, every third or fourth day, as required.

Samples of cotton foliage with exposed fipronil residues were collected from each treated plant 1, 2, 6, 12 and 24 d after application. Two mature leaves from each plant, approximately 200 cm<sup>2</sup>, were randomly selected, cut and placed singly into plastic bags and taken for laboratory bioassay. Plastic Petri dishes (90 mm diam.) were modified to provide ventilation and to facilitate bee feeding for the bioassays, by cutting two circular holes (30 mm diam.) in the middle of the lid and covering them with nylon mesh which was glued to the lid. Each excised cotton leaf was directly placed onto the base of a Petri dish, to avoid hand contamination which may have reduced the deposited fipronil, then cut exactly to fit in the dish on top of a filter paper (Whatman No. 1, Hillsboro, OR, USA) that was located on the base of the dish.

One of the pair of discs from each plant was allocated to each of two bee exposure times. The leaf discs were placed so their upper surface would be exposed to the bees. Seven-day old worker bees were collected and caged as previously described (6.2.2.1). Batches of ten anaesthetized bees were randomly allocated to each of the treatment concentrations, and were placed into their respective Petri dish. They were exposed continuously to the treated leaves for two different time periods, 3 h or 24 h. All

treatments were replicated six times. Thus, for each bioassay 12 Petri dishes were used (Figure 6.2). Bees in the 3 h exposure treatment were immediately transferred after this time had elapsed to similarly modified, but clean, Petri dishes with a filter paper on their base. They were then provided with 1 g bee candy which was placed on the mesh. At the same time, bees in the 24 h exposure treatment were also similarly fed (Figure 6.3). Food was not provided to bees earlier, in order to maximize their movement over the treated leaf surface rather than remaining static and eating candy. Mortality was assessed 24 h after initial exposure.



**Figure 6.2 Experimental setup for assessing toxicity to honeybees of fipronil residues on cotton foliage exposed to normal weather conditions. Petri dishes labeled 1 contain bees which had already been exposed to treated leaves for 3 h, and have been removed to clean dishes. Those labeled 2 contain treated leaves and bees exposed to them for 24 h.**

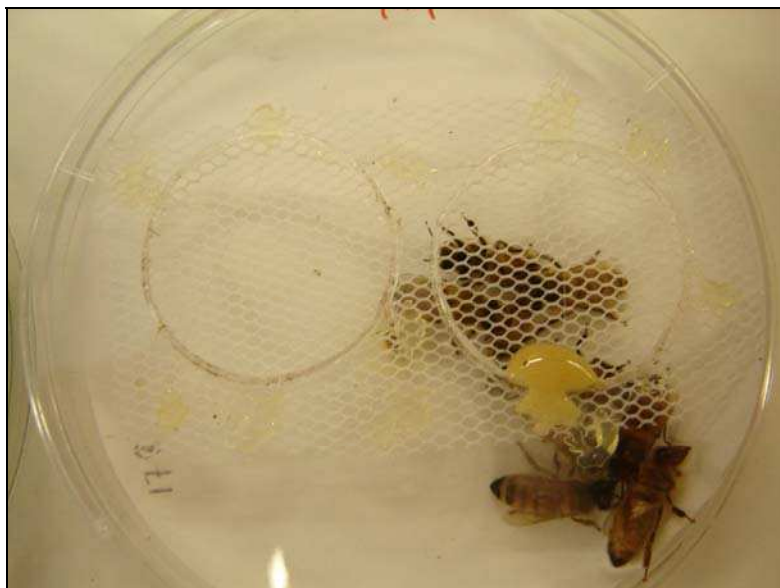

**Figure 6.3 Close-up of one of the experimental Petri dishes (with two circular holes) used for assessing toxicity to honeybees of fipronil residues on cotton foliage.**

#### ***6.2.4 Statistical Analysis***

Probit analysis was carried out for dose-mortality (topical and oral), and heterogeneity of regressions was determined by the Pearson  $\chi^2$ -test statistics (Busvine, 1971). Abbott's (1925) formula was used to correct for the natural mortality prior to Probit analysis.

Data on toxicity of aged residues were analysed using mixed general linear model of analysis of variance (ANOVA) SPSS® for Windows™ Version 14 (SPSS Inc. 2007). The age of residue, rate of fipronil and time of bee exposure to the residues were fixed factors and replicates was a random factor. The assumption of normal distribution was checked using P-P plot and homogeneity of variance using Levene's test of equality of error variances. When the assumption of homogeneity of variance was met Ryan's Q test was used to separate treatment means and when the assumption was not met Dunnett's T3 test was used. Data for all analyses were arcsin (sqrt(X)) transformed. The value X was the proportion of dead bees.



## 6.2 RESULTS

### 6.3.1 Topical acute toxicity of fipronil to honeybees

The results from the analysis of the acute topical toxicity investigation are presented in Table 6.1. The calculated LD<sub>50</sub> and LD<sub>90</sub> values, combining all three replicates, were 1.9 ng / bee (15.1 ng / g) and 2.8 ng / bee (22.2 ng / g), respectively. The estimated regression line has  $r^2 = 0.876$ .

**Table 6.1 Statistical summary of results for acute toxicity of topically applied fipronil (1 µL) to seven-day old *A. mellifera* workers, after 24 h.**

Replicate	n <sup>a</sup>	Slope <sup>b</sup> ± SE	LD <sub>50</sub> <sup>c</sup> (95% CL <sup>d</sup> )	LD <sub>90</sub> <sup>c</sup> (95% CL)	χ <sup>2</sup>	df <sup>e</sup>	P <sup>f</sup>
1	90	6.38 ± 1.12	1.8 (1.5-2.0)	2.8 (2.5-3.5)	6.42	4	0.170
2	90	7.30 ± 1.28	2.1 (1.5-2.6)	3.1 (2.6-7.5)	8.09	4	0.088
3	90	9.15 ± 1.63	1.9 (1.7-2.1)	2.6 (2.4-3.1)	2.14	4	0.709
Combined	270	7.61 ± 1.34	1.9 (1.6-2.2)	2.8 (2.5-7.0)	20.97	16	0.180

<sup>a</sup> number of insects tested

<sup>b</sup> Probit model : Probit (p) = Intercept + BX (Covariate X are transferred using the base 10.000 logarithm).

<sup>c</sup> LD<sub>50</sub> and LD<sub>90</sub> data were determined by probit analysis (SPSS Version 15, 2008); concentration (ppm) in alcohol

<sup>d</sup> CL confidence limits.

<sup>e</sup> Statistics based on individual cases differ from statistics on aggregated cases.

<sup>f</sup> Since the significance level is greater than 0.150, a heterogeneity factor is used in calculation of confidence limits.

### 6.3.2 Oral acute toxicity of fipronil to honeybees

The results from the analysis of the acute oral toxicity investigation are presented in Table 6.2. The estimated LC<sub>50</sub> and LC<sub>90</sub>, combining all four replicates were 0.4 ng / bee and 1.3 ng / bee, respectively. The estimated regression line has  $r^2 = 0.710$ .

**Table 6.2 Statistical summary of results for oral toxicity of honey syrup containing fipronil to seven-day old *A. mellifera* workers, after 24 h.**

Replicate	n <sup>a</sup>	Slope <sup>b</sup> ±SE	LC <sub>50</sub> <sup>c</sup> (95% CL <sup>d</sup> )	LC <sub>90</sub> <sup>c</sup> (95% CL)	χ <sup>2</sup>	df <sup>e</sup>	P <sup>f</sup>
1	90	5.72 ± 1.37	0.6 (0.5-0.7)	1.0 (0.8-1.5)	3.42	3	0.331
2	90	2.89 ± 0.62	0.3 (0.2-0.5)	1.0 (0.7-2.0)	5.04	3	0.168
3	90	3.05 ± 0.68	0.4 (0.3-0.5)	1.1 (0.8-2.2)	4.21	3	0.239
4	90	1.78 ± 0.48	0.4 (0.2-0.6)	2.1 (0.1-0.1)	2.07	3	0.557
Combined	360	3.63 ± 0.44	0.4 (0.4-0.8)	1.3 (0.9-2.0)	24.24	15	0.061

<sup>a</sup> number of insects tested

<sup>b</sup> Probit model : Probit (p) = Intercept + BX (Covariate X are transferred using the base 10.000 logarithm).

<sup>c</sup> LC<sub>50</sub> and LC<sub>90</sub> data were determined by probit analysis (SPSS Version 15, 2008); concentration (ppm) in alcohol

<sup>d</sup> CL confidence limits.

<sup>e</sup> Statistics based on individual cases differ from statistics on aggregated case.

<sup>f</sup> Since the significance level is greater than 0.150, a heterogeneity factor is used in calculation of confidence limits.

### 6.3.3 Bioassay of fipronil residues

#### a) Assessment of residual toxicity under laboratory conditions:

##### I. Estimating hazardous doses of fresh fipronil residues for honeybees

The estimated regression lines of probit transformed mortality vs time of exposure together with their 95% confidence limits for the 1 and 10 ppm treatments in the preliminary investigation are presented in Figure 6.4. The 0.1 ppm treatment did not show significant mortality. Although the 95% CL and r<sup>2</sup> values are supportive of a good relationship between these two parameters, the relatively low number of bees tested (n = 70) does not warrant further analysis.

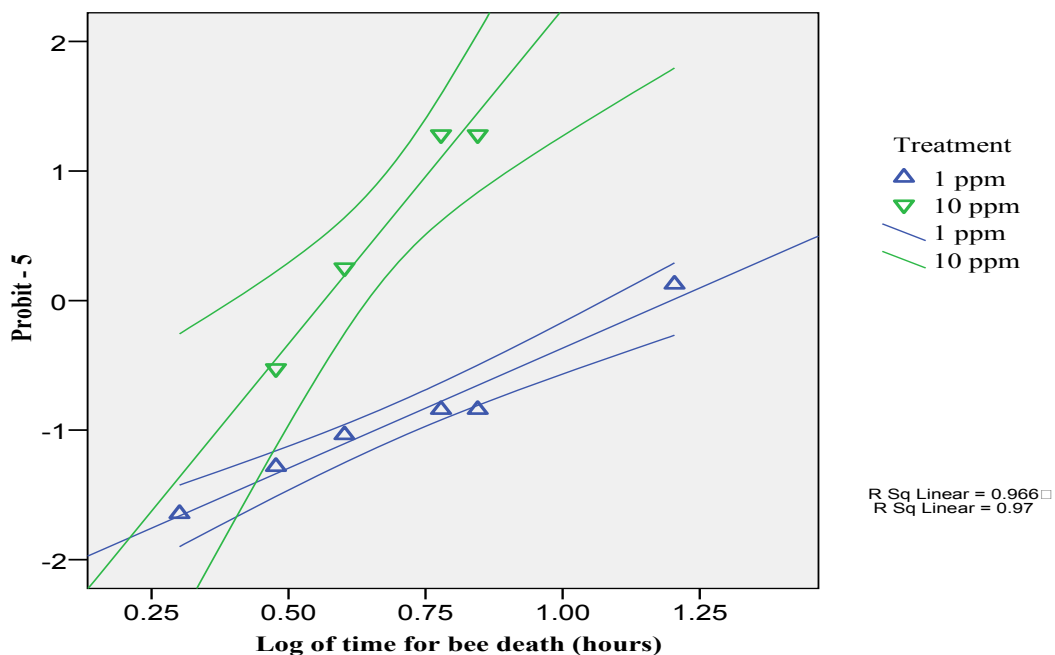

**Figure 6.4** Estimated regression lines and their 95% CL for time (h) for death of honeybees continuously exposed to 1 ppm and 10 ppm a.i. (w/v) fresh residues of fipronil.

### 6.3.3.1 Assessment of residual toxicity of fipronil deposits to honeybees

Results for the laboratory residue bioassay are presented in Tables 6.3, 6.4. With one day-old residues, death of bees occurred rapidly, and this rapidity increased with length of exposure to the residues. In fact, 100% mortality occurred prior to the first assessment point (1.5 h) for the 20 and 40 min exposure times. However, after 40 min exposure, all bees were still alive. Hence, death occurred between 40 and 90 min.

As the age of the fipronil deposits increased, within each exposure time treatment, the time to reach 50% and 90% mortality increased. In addition, mortality was higher with longer exposure times to the residues. Thus, with Day 42 residues, 50% and 90% mortality following 1 min exposure to treated vials were achieved at 25.6 h and 33.3 h after initial exposure; the comparative times for 40 min exposure were 3.2 h and 4.1 h, respectively.

**Table 6.3 Statistical summary of results for time to reach 50% mortality of *A. mellifera* workers when exposed to various age fipronil residues, at a number of exposure periods.**

Exposure time (min)	Time (h) from commencement of exposure to reach 50% honeybee mortality (95%CL)			
	1	10	20	40
<b>Age of residues (day)</b>				
1	4.5 (0.6-8.4)	1.9 (1.0-2.8)	na*	na
14	18.0 (14.2-22.7)	3.8 (2.5-4.8)	na	na
28	23.6 (20.2-27.1)	4.8 (3.8-5.7)	3.7 (2.5-5.0)	2.9 (2.7-3.1)
42	25.6 (21.9-29.8)	6.0 (5.0-6.9)	5.8 (4.7-6.9)	3.2 (3.0-3.4)

\* 100% mortality at first assessment time (1.5 h)

**Table 6.4 Statistical summary of results for time to reach 90% mortality for *A. mellifera* workers when exposed to various age fipronil residues, at a number of exposure periods.**

Exposure time (min)	Time (h) from commencement of exposure to reach 90% honeybee mortality (95% CL)			
	1	10	20	40
<b>Age of residues (day)</b>				
1	12.7 (8.7-18.5)	3.3 (2.4-4.7)	na*	na
14	26.2 (21.6-33.6)	5.0 (4.0-6.6)	na	na
28	31.8 (28.2-37.4)	6.2 (5.3-7.6)	6.1 (4.8-8.5)	3.8 (3.6-4.1)
42	33.8 (29.7-40.4)	7.4 (6.6-8.9)	8.1 (7.0-9.4)	4.1 (3.9-4.4)

\* 100% mortality at first assessment time (1.5 h)

### ***6.3.3.2 Bioassay of fipronil residues on cotton foliage collected from the field***

Bee mortality was consistently higher in the full rate fipronil, and also for bees exposed to similar residues for 24 h compared to 3 h. For the full rate treatment, mortality < 100% occurred with 1 day-old residues when bee exposure was 3 h, but did not reach this point for 24 h exposure until residues were 12 days old. With 24 day-old residues, mortality in all treatments was negligible.

**Table 6.5 The percentage of bee mortality after exposing them to residues of field rates of fipronil, periodically (3 h) or continuously (24 h), after 24h.**

	Application rate			
	Half rate		Full rate	
Time of exposure (h)	3	24	3	24***
Age of residues (day)				
1	75** ± 13.3 <sup>a</sup>	60.0 ± 20.0 <sup>ab</sup>	100.0 ± 0.0 <sup>a</sup>	100.0 ± 0.0 <sup>a</sup>
2	60 ± 13.1 <sup>a</sup>	86.7 ± 4.9 <sup>b</sup>	70.0 ± 17.5 <sup>a</sup>	100.0 ± 0.0 <sup>a</sup>
6	40 ± 17.8 <sup>ab</sup>	61.7 ± 19.5 <sup>ab</sup>	66.7 ± 16.8 <sup>ab</sup>	100.0 ± 0.0 <sup>a</sup>
12	8.3 ± 4.7 <sup>b</sup>	35.0 ± 20.6 <sup>ab</sup>	31.7 ± 14.4 <sup>b</sup>	33.3 ± 13.8 <sup>b</sup>
24	6.6 ± 4.9 <sup>b</sup>	0.0 ± 0.0 <sup>c</sup>	0.0 ± 0.0 <sup>c</sup>	0.0 ± 0.0 <sup>c</sup>

\*All values in the same column with the same letters did not differ significantly at  $P < 0.05$

\*\*Mean percentage mortality ( $n = 6$ ) ± SE

\*\*\*Data could not meet assumption of normal distribution even after transformation so data analysis was not performed

Statistical analysis showed significant rate × age of residue interaction ( $F_{8,155} = 11.837$ ,  $P < 0.001$ ), and age of residue × time of exposure interaction ( $F_{4,155} = 2.385$ ,  $P = 0.05$ ), hence analyses were performed for each exposure time of each rate separately. There were significant differences between age of fipronil residues in the half rate treatment, when bees were exposed to treated leaves for 3 h ( $F_{4,20} = 9.779$ ,  $P < 0.001$ ) and 24 h ( $F_{4,20} = 4.052$ ,  $P = 0.014$ ). When bees were exposed to the residues for 3 h, mortality was significantly higher in 1 and 2 day-old residues compared to 12 and 24 day-old ones. There were no significant differences between other aged residues. When bees were exposed for 24 h to treated leaves of the same treatment rate, 2 day-old residues were significantly different to 24 day-old residues. There were no significant differences between other differently aged residues.

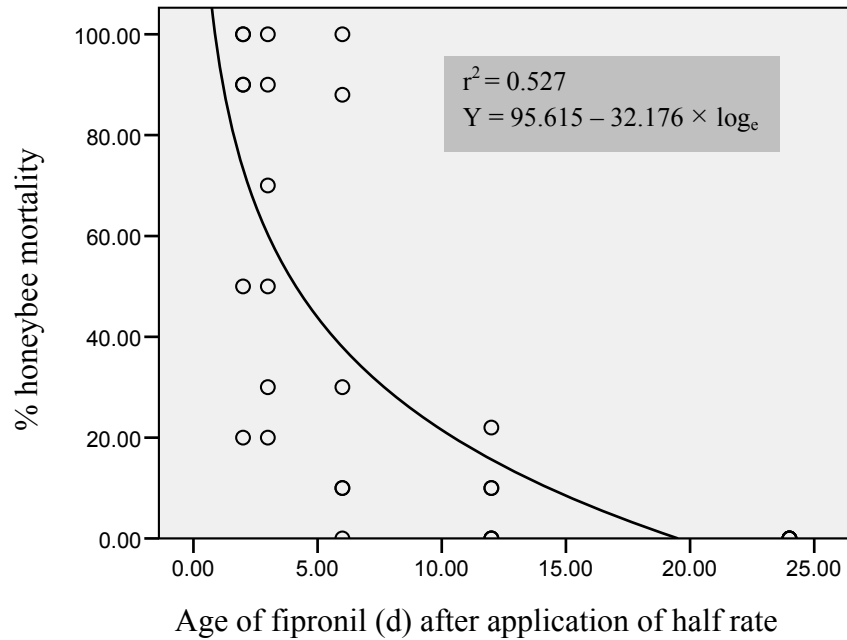

**Figure 6.5 Mortality of honeybees, after 3 h exposure to aged residues of half rate fipronil, on cotton leaves (mortality recorded 24 h after commencement of exposure).**

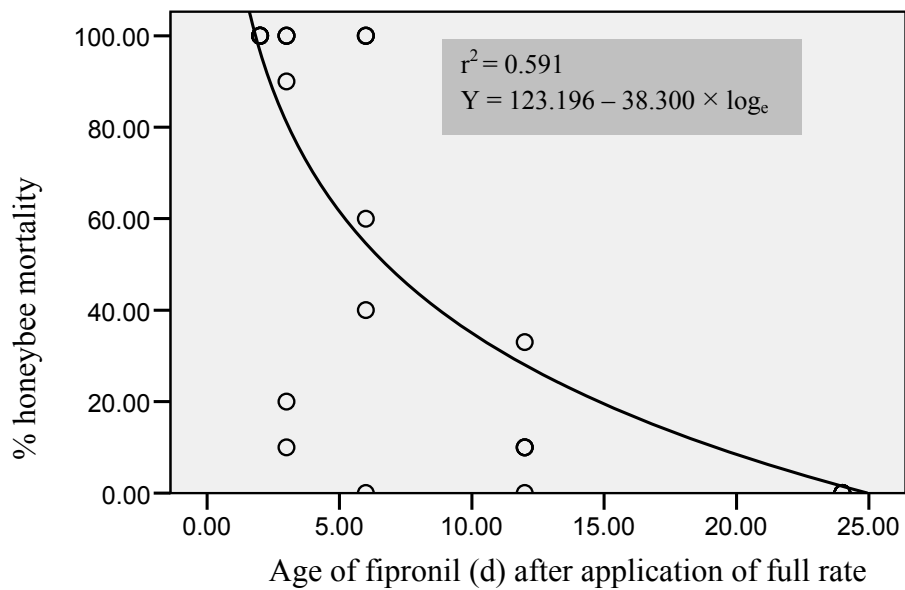

**Figure 6.6 Mortality of honeybees, after 3 h exposure to aged residues of full rate fipronil, on cotton leaves (mortality recorded 24 h after commencement of exposure).**

There were significant differences between the different age residues with full rate fipronil, when bees were exposed to treated leaves for 3 h ( $F_{4,20} = 10.073$ ,  $P < 0.001$ ). Mortality of bees exposed for 3 h to 1 day-old residues was significantly higher than for 12 and 24 day-old residues. Two day-old residues were significantly different from 24 day-old residues. There were no significant differences between other differently aged residues. When bees were exposed to 24 h residues, data analysis could not be performed because there were no variations between replicates in four out of five tested age residues and so the assumptions of analysis of variance could not be met.

#### **6.4 DISCUSSION**

The combination of residual and oral toxicity studies provided valuable information on the highly hazardous nature of fipronil to honeybees. The data show high mortality, via acute toxicity, of worker bees when they were exposed to direct contact (e.g. via sprays), oral (e.g. ingestion of nectar, contaminated pollen and honey), and to fresh and aged residues of fipronil.

In the current study, the  $LD_{50}$  of fipronil, when 1  $\mu\text{L}$  was applied topically to the dorsal prothorax of 7 day-old *A. mellifera* workers, is 0.002  $\mu\text{g}$  / bee. This figure is similar to, but slightly lower than, that reported by Anon (2000, cited in Cox, 2005) of 0.004 - 0.005  $\mu\text{g}$  / bee, 0.006  $\mu\text{g}$  / bee (Decourtye, 2002, cited in Hassani *et al.*, 2005; Roper, 2002, cited in Chauzat *et al.*, 2006), 0.0037-0.006  $\mu\text{g}$  / bee (Anon, 2002, cited in Colin *et al.*, 2004), 0.004  $\mu\text{g}$  / bee (Anon 1995c, cited in Tingle *et al.*) and  $< 0.005$   $\mu\text{g}$  / bee (Hassani *et al.*, 2005). However, it differs greatly from the first reported figure of 0.013  $\mu\text{g}$  / bee by Mayer & Lunden (1999), which is much higher than any subsequent reports.

Differences between my results and those of others may be a result of the amount applied (for instance, Mayer & Lunden [1999] applied 2  $\mu\text{L}$ ), the carrier (Mayer & Lunden [1999] used acetone, and I used ethanol), or the age of bees tested (Chauzat *et al.*, 2006). Both life stage and age impact on insect response to intoxicants (Busvine, 1971). I used verified 7 day-old workers which I maintained in hives, so that I could use uniform organisms for the bioassays. Mayer & Lunden (1999) used presumably 4-5 week-old bees,

and Hassani *et al.* (2005) used bees of unknown age because they “caught worker bees through a hole in the top of the hive”. Decourtye *et al.* (2005), on the other hand, used 14 day-old bees which were reared under artificial conditions, in an incubator. The youngest stages of larvae are generally the most susceptible, and newly emerged adult bees are more susceptible to DDT and carbaryl (Davis, 1989), and aldicarb, sulfone and methomyl (Atkins & Kellum, 1986). In contrast, older bees are more susceptible to endosulfan and malathion (Atkins & Kellum, 1986). With foraging adult bees, it is also difficult to distinguish between mortality due to natural ageing or exhaustion due to intense foraging activity and mild poisoning. While older foraging workers would be more likely to be directly exposed to fipronil, contaminated bees, nectar and/or pollen would potentially expose younger bees and larvae in the hive to the pesticide.

Fipronil was also highly toxic to honeybees when ingested. In the current study, the LC<sub>50</sub> of fipronil, when provided in contaminated honey syrup to 7 day-old *A. mellifera* workers after 24 h, was 0.0004 % a.i. It was not possible to assess the LD<sub>50</sub>, as I did not measure the intake of individual bees. However, the LD<sub>50</sub> has been reported to be 0.006 µg / bee after 48 h (Decourtye, 2002), and 0.004 µg / bee after 24 h (Roper, 2002). Fipronil has been detected in some pollen samples (Chauzat *et al.*, 2004; Jimenez *et al.*, 2007), and can thus pose a risk to larvae and young non-foraging bees.

The above figures relate to direct mortality of honeybees. The effects on bee foraging have occurred at even lower exposures (Colin *et al.*, 2004). Decourtye *et al.* (2005) compared the sublethal effects of nine pesticides on olfactory learning performance (proboscis extension response) in *A. mellifera*, and concluded that even doses lower than 5% of the LD<sub>50</sub> could impact negatively. Hassani *et al.* (2005), however, reported that concentrations of fipronil approximately an order of magnitude below the LD<sub>50</sub>, did not interfere with the locomotive activity of honeybees regardless of the route of administration (topical and oral at 0.1, 0.5, and 1 ng / bee). They also recorded that while these concentrations impaired olfactory learning they did not impair learning or memory retention (Hassani *et al.*, 2005).



Fipronil has also been reported to be highly toxic to bees other than *A. mellifera*. For example, Mayer & Lunden (1999) found that while alkali bee, *Nomia melanderi*, was less susceptible to fipronil ( $LD_{50} = 1.130 \mu\text{g} / \text{bee}$ ) than honeybees, alfalfa leafcutter bee, *Megachile rotundata*, was more susceptible, ( $LD_{50} = 0.004 \mu\text{g} / \text{bee}$ ).

The laboratory and potted plant bioassays to assess activity of fipronil residues, in the current study, indicate that fipronil is highly toxic to honeybees for an extended period after its initial application. In the laboratory in Pyrex vials, fipronil was still toxic even after six weeks. However, there are two reasons why this time period may be exaggerated. First, the rate used was much higher than the recommended field rate for cotton; second, the residues were not exposed to sunlight or other external meteorological conditions.

In the potted plant trials, in which residues were exposed to a plant leaf surface, sunlight and fluctuating temperatures, but not heavy rain, fipronil applied at the full recommended rate (0.025 kg a.i. / ha) was still toxic to bees between 12 and 25 d after application, and at half recommended rate for more than 12 d. This residual activity could be shorter under full field conditions, where treated plants would be exposed to rain and agricultural practices. Considering normal honeybee foraging behaviour, 3 h exposure to fipronil residues is a realistic timeframe to assess likely toxicity in the field.

There are very limited published data with which to compare my results. Mayer & Lunden (1999) reported that mortality of honeybees, when exposed for 24 h to 2 h- and 8 h-old fipronil field residues applied at a rate of 0.22 kg / ha to canola leaves, was 76% and 46%, respectively. They concluded that fipronil at rates of 0.11 kg / ha could be considered as non-hazardous to honeybees, and could be applied in the evening only to flowering crops where bees are foraging. Based on my results, this conclusion is incorrect. My data are supported by Mulrooney (1999) who recorded 100% mortality in cotton weevil after exposure to 3 day-old residues of fipronil on field cotton, initially applied at 0.056 kg a.i. / ha. It is also consistent with the current label recommendations for use of fipronil (Regent 200SC APVMA Approval Number 60284/0406, Nufarm Australia Limited, 2006):

“Do not apply where bees from managed hives are known to be foraging and crops, weeds or cover crops are in flower at the time of spraying, or are expected to flower within 28 days”.

While it was not obvious in my investigations, it is reported that fipronil residues increase their toxicity several days after their initial application (Anon, 2006). The photodegradation of fipronil has been further studied by several groups, who have discovered four photoproducts (Gunasekara *et al.*, 2007; Hainzl & Casida, 1996; Bobe *et al.*, 1998). Fipronil-desulfinyl has been reported to be the major product from fipronil application to corn, peas, or pears; thus it is proposed to be the primary persistent residue on foliage-treated crops (Hainzl & Casida, 1996). It has a half-life of 41–55 days (Ying & Kookana, 2002), and is ten times more toxic than fipronil itself (Cox, 2005).

The toxicity of fipronil may also be increased if it is mixed with adjuvants. Mayer & Lunden (1999) reported that tank mixing fipronil with the non-ionic organosilicone surfactant Sylgard (Norac Concepts Inc., Guelph, Ontario, Canada) significantly increased honeybee mortality, although the synthetic latex-based adjuvant Bond (Loveland Industries, Greenly, CO, USA) and the di-1-pentene compound Nufilm (Miller Chemical & Fertilizer Corp., Hanover, PA, USA) did not. Mulrooney (1999) also found that when oil was used as an adjuvant, fipronil was three times more toxic.

A number of insecticides can be repellent over a range of concentrations (Mamood & Waller, 1990), reducing likely field toxicity, especially to non-target species. This is not the case with fipronil. Mayer & Lunden (1999) found that honeybees were not repelled from canola crops after fipronil was applied at a rate of 0.22 kg / ha, and honeybees could not detect fipronil at up to 50 ppm in honey syrup. Both of these levels of fipronil are higher than were used in my investigations, and much higher than that currently recommended for cotton in Australia. This means that fipronil residues in cotton are unlikely to be detectable by honeybees.

## **6.5 CONCLUSIONS**

- These studies show that fipronil is highly toxic to honeybees via direct spray contact, ingestion, and contact with residues.
- Fipronil is likely not only to be toxic to foraging honeybees, but also to young adult bees and maybe larvae.
- Even when exposed to high doses of fipronil, bee death does not occur until after 40 min. This may allow foraging bees, especially if exposed to lower doses, to return to their hive, directly contaminated and/or with contaminated nectar and pollen.
- Fipronil residues remain toxic for a long time, even when exposed to weather conditions.
- The use of fipronil in flowering cotton is unlikely to be compatible with use of managed honeybees.
- For highly bee-toxic pesticides, exposing bees to treated leaves for 3 h, rather than 24 h, should be sufficient to assess their residual toxicity.

## CHAPTER 7

### GENERAL DISCUSSION

#### 7.1 GENERAL DISCUSSION

My studies were conducted to investigate the importance of honeybees in transgenic Bt cotton pollination under Australian conditions, and to quantify the effect of honeybee pollination on yield and quality parameters. I demonstrated that presence of honeybees increased weight of cotton bolls by ~37% and weight of lint by ~38-40%, while maintaining high lint quality, although this was in caged investigations which are likely to overestimate the honeybee contribution. At the current Australian average lint yield of 2,027 kg / ha (Anon, 2008a), valued at A\$ 3560, the increased return would be A\$ 1357 / ha. Thus, even if the increase in lint yield was only half that estimated (19%), an increased return to Australian growers would be A\$ 679 / ha. This needs to be considered in light of current hive rental costs of A\$ 45 per hive for cotton.

To achieve these results, I used a nominal stocking rate of 8-16 colonies / ha. I have discussed the issue of calculating a suitable stocking rate for cotton later in this chapter. One consistent result from all of my honeybee foraging and pollination behaviour investigations was that cotton flowers were not commonly visited by them. Although cotton flowers produce both nectar and pollen, they were less attractive to honeybees in the presence of competing flowers, a result confirming previously reported studies (Moffett *et al.*, 1975a; Loper & Davis, 1985; Waller *et al.*, 1985a; Vaissiere, 1991a; El-Sarrag *et al.*, 1993; Rhodes, 2002).

A number of my investigations thus focused on how to increase bee cotton flower visitation rates, and how to optimize their pollination efficacy. Manipulating pollen in-hive has been reported to increase honeybee pollen collection (Hirschfelder, 1951; Lindauer, 1953; Rashad & Parker, 1958; Free, 1967; Liven & Loper, 1984; Chambers, 1985; Camazine, 1990; Dreller *et al.* 1999; Danka, 2005; Tsirakoglou *et al.*, 1997), so I evaluated a number of these techniques to see if they would increase pollination in cotton.

It was unclear whether my attempts to increase pollen collection by restricting pollen entry into hives by using pollen traps were successful under my experimental conditions, despite them being reported as successful by other workers (Lindauer, 1953; Rashad & Parker, 1958; Webster *et al.*, 1985; Thorp, 1979). Pollen traps initially slowed down the number of out-going bees (flight activity), but after three weeks, bees had adapted to them and flight activity returned to normal. Under conditions of pollen shortage, a colony's foraging bee cohort may be redirected to collect pollen, or may collect larger pollen pellets (Fewell & Winston, 1992; Eckert *et al.*, 1994), which may partially compensate. However, there was no evidence that use of traps increased pollen collection in my investigations.

The use of pollen traps negatively affected in-hive conditions, even over a relatively short period of 25 d. Colonies fitted with 30% efficient traps stored less pollen and, while their brood area did not decrease, they were unable to increase brood production as occurred in identical non-trapped colonies. Pollen traps also reduced honey production, which could be explained by the foraging bees switching from nectar to pollen collection.

Even if there was an increase in pollen gathering activity from use of pollen traps, this was not reflected in an increase in collection of cotton pollen. Analysis of trapped pollen confirmed less than 5.2% of it had come from cotton, despite the hives being placed adjacent to a flowering cotton crop. This was further confirmation of the unattractiveness of cotton flowers and/or cotton pollen. An indication that cotton pollen itself was unattractive was the observation of bees scraping it off their bodies, which has been reported by other investigators as rejection behaviour. However, I only observed this behaviour in nectar gatherers.

SEM studies of bee-collected pollen showed that the majority of grains were smaller and generally smoother than cotton, which had large spines. Furthermore, cotton pellets were the smallest, and were less tightly packed, suggesting that their grain morphology may be responsible for their rejection by honeybees. Interestingly, random cotton pollen grains

were observed in a number of non-*Gossypium* pellets, suggesting contamination from a previous cotton pellet in the trap. Failure to detect cotton pollen by previous investigators (Waller *et al.*, 1985a; Rhodes, 2002) might be explained by the small size and loose nature of cotton pellets and the efficiency of their pollen traps.

A different method evaluated for its ability to increase honeybee activity and pollen collection was feeding colonies with a pollen supplement, and thereby increasing brood production (Standifer *et al.*, 1971, 1973; Herbert & Shimanuki, 1980; Waller *et al.*, 1981a). While feeding soybean-pollen patties increased the area of brood it did not, apparently, increase pollen collection. Feeding colonies significantly increased their flight activity, area of stored pollen and sealed brood area. However, areas of stored pollen and brood may have been a result of the utilization of the in-colony feed and not field pollen collection. In the current study, I used stored pollen area and amount of trapped pollen as indicators of pollen collection rather than observing returning bees at the hive entrance (cf. Danka, 2005). While the latter method assesses the proportion of pollen gatherer bees, it cannot assess the amount of cotton pollen collected.

Alternative methods for assessing pollen gathering activity of bees were considered, but all of them, such as individual hand collection (Kühnholz & Seeley, 1997), sweep netting (Levin & Loper, 1984; Ruibok *et al.*, 1986; Danka, 2005) and vacuum collection (Gary & Lorenzen, 1988) were either tedious, disrupted normal bee movement, or could damage bees or dislodge pollen pellets. I therefore developed a prototype incoming-bee trap for this purpose, based on a pollen trap design, which was portable, made of wood and designed to fit on the base of a standard Langstroth hive body. This apparatus was attached to a hive box, used as the bottom board and provided the normal entrance to the hive. I was unable to have sufficient samples of the trap constructed to complete this work, so details of its evaluation have not been included in this thesis. A drawing of the trap design is presented in Appendix II.

Feeding did not increase honey production, and thus nectar collection, in the current study. This result is similar to that reported by Goodwin *et al.* (1994), but different from

Purdie & Doull (1964), Doull (1980b), Nabors (2000), and Shoreit & Hussein (1993). These apparent inconsistencies may be consequence of a crop, and not a technique, effect. Fitting pollen traps to colonies, however, significantly reduced their honey production. This is in agreement with a number of other reports (Rashad & Parker, 1958; Hirschfelder, 1951; Moriya, 1966; Lavie, 1967; Duff & Furgala, 1986).

Overall, there was little honey production in any of the investigation hives. This was at first surprising to me, as cotton has been reported as a honey melliferous plant (Parks, 1921; Butler *et al.*, 1972; El-Banby *et al.*, 1985). However, my findings may have been due to honeybee competition from the high stocking rate, or because of competition by other arthropod species, particularly pollen beetles. This investigation involved a late planted cotton crop, in which pollen beetle populations much higher than normal occurred.

While feeding colonies pollen supplements increased their flight activity, it did not increase bee visitation to cotton flowers. I therefore assessed whether application of the commercial QMP bee attractant, Fruit Boost<sup>®</sup>, would be able to achieve this outcome. Despite QMP showing promising results in a number of other crops (Currie *et al.*, 1992a, b; Winston & Slessor, 1992; Naumann *et al.*, 1994) it was not successful under my experimental conditions. None of the parameters of honeybee activity (*viz.* fruit set, yield and lint quality) increased significantly after the application of Fruit Boost<sup>®</sup> at concentrations of 50 and 500 QEQ / ha.

There are three factors that may have contributed to this lack of response: unfavourable weather conditions (temperatures too high) for honeybee foraging on flowers; I may have not used the optimal dose of QMP, which appears to be crop-specific; and the stocking rate (0.7 colonies / ha) may have been too low.

This was the first attempt to use QMP for cotton pollination and, as far as I can determine, in any field crop. These investigations were, by necessity, conducted with 0.1 ha plots, with three replicates and for one season in one location. Therefore my results are

only preliminary. It is unclear whether the climatic conditions during which cotton is flowering would be conducive to use of QMP, to increase pollination. In addition, the cost of application over a period of up to 4-5 weeks is likely to be prohibitive.

One of the most interesting observations from my investigations was that the overwhelming majority (~80%) of honeybees visiting cotton flowers did not enter them, but accessed floral nectar from outside the flower. This meant that they did not contribute to pollination. There is only one previous report of this phenomenon (Wafa & Ibrahim, 1959), although they did not suggest it was as common as in my trials. The most likely explanation is that bees avoided flowers occupied by pollen beetles. I observed in my first field trial that some honeybees foraging on cotton flowers hovered around the flower, or landed near flowers, but did not enter them. I was able to confirm in my trial in the third year that bees, when given a choice, preferred to enter flowers not occupied by pollen beetles. The first year's cotton crop was late season, and the second and third year crops were mid season. This meant that a number of flowers, especially in the later blooming period of my investigations, contained pollen beetles. Given that I showed that pollen beetles at low numbers in flowers do not contribute to pollination, and at high numbers damage floral structures and cause boll shedding, this suggests that planting cotton crops as early as possible is likely to avoid the direct or indirect impacts of pollen beetles on pollination. It also suggests that for late crops when pollen beetles are likely to be present, a higher bee stocking rate might be required to achieve the same pollination efficacy as for main season crops.

In my field observations I focused on the foraging behaviour of individual honeybees in cotton fields. Both nectar and pollen gatherers appeared to contribute to cross pollination. Although it has been frequently reported that bees prefer extrafloral nectaries in non-Bt cotton varieties, this was not the case in my experiments, since no bees were observed at these nectaries.

Based on my three field investigations (2004-5, 2005-6, 2006-7) honeybee visitation rate on cotton flowers was generally correlated to the stocking rate. These investigations also



suggest that a bee visitation rate of 0.5% appears to be a reliable indicator for determining the level of bees required to increase cotton yield. This is preferable to using a recommended stocking rate, which might be area-dependent and vary according to surrounding flora and other conditions.

The key impetus for conducting investigations with honeybees in cotton was the widespread adoption of transgenic Bt varieties in Australia and, with it, the associated reduction in pesticide use. Unfortunately, the increased importance of mirids and other sucking pests of squares, flowers and young bolls in this regime, means that highly toxic pesticides, particularly fipronil, are often applied at flowering. This is clearly the greatest obstacle to implementation of my positive findings on honeybee pollination in cotton. Even at the ARCI, the only location where I could effectively conduct my pollination experiments, I still had to utilize mid and late season crops for most of my field studies to avoid bee mortality from insecticides applied to nearby cotton crops by other researchers. Through a series of bioassays and potted plant trials, I confirmed the highly toxic nature of fipronil to honeybees, whether directly applied, ingested, or via contact with residues on treated surfaces. Even more important was its highly residual nature, with worker bee mortality occurring up to 25 d for the maximum recommended rate and 20 d for half of the maximum recommended rate, when sprays were applied to cotton foliage. This residual activity means that use of fipronil and honeybees is incompatible.

One option which is being currently recommended as compatible with IPM is to use fipronil at one third of the maximum recommended rate (Mensah pers. comm., 2007). Farmers often incorporate salt (sodium chloride) with this lower rate, to maintain its efficacy. However, my data suggest that this rate, even without the salt, would not be suitable.

A second option would be to use alternative, more bee-friendly mirid control methods. These could include less residual synthetic insecticides such as dimethoate, biological pesticides such as entomopathogens or botanical insecticides. Other methods currently under investigation are use of semiochemicals to repel pests, or to attract them to

pesticides (attract-and-kill) (Gregg *et al.*, 2004; Hossain *et al.*, 2006). Alternatively, supplementary sprays such as Amino-Feed®, Envirofeast®, and Pred-Feed® can be applied to crops to act as artificial-plant-derived foods (Wade *et al.*, 2008) or kairomones can be applied to attract beneficial natural enemies (James, 2003). One other method is the growing of strips crops such as lucerne, *Medicago sativa*, which either attract beneficial species, or can be used as trap crops (Mensah *et al.*, 2002).

Before any of these methods could be used with honeybees, the toxicity and residual activity of any insecticides and/or entomopathogens would have to be determined. As well, their impacts on honeybee pollination behaviour, such as repellence (if applied to cotton) or attractiveness (if applied away from cotton) need further investigation.

The period of time that cotton flowers need to be exposed to honeybees for optimum pollination benefits will determine the maximum residual activity required for compatible insecticides. I investigated whether a window of 10 d in the middle of a 25 d flowering period would be sufficient to provide adequate honeybee pollination. While not ideal (it was estimated to contribute 55% of the increase attributable to honeybee pollination for weight of bolls / m, but only 36% of the increase in weight of lint / m) it appears that use of insecticides at flowering prior to release of bees should have a residual activity of less than 7 d. After the 10 d pollination period, more toxic or residual pesticides could be used. It should be noted that I used a high bee stocking rate (16 colonies / ha) in this investigation, and this may be required to take full advantage of the shortened time window. However, this strategy would have to be economically evaluated.

In addition to when bees may be used directly to pollinate cotton, pesticide use in cotton impacts on beekeeping more generally. This is because Australian beekeeping is highly migratory, and apiarists move their hives to suitable locations to capture major honey and pollen flows. Beekeepers often place apiaries in cotton growing areas, principally for honey production from the coolibah tree, *Eucalyptus microtheca*, which grows naturally in these areas, and flowers at the same time as cotton (Anon, 2008b). Apiaries are therefore subjected to potential damage from pesticides, particularly fipronil, if bee

foragers visit treated cotton crops, or are exposed to off-target drift of pesticides, which are commonly applied by air.

Meetings are regularly held between representatives of the cotton and beekeeping industries, together with researchers from the NSW and Qld Departments of Primary Industries, to develop a voluntary Code of Practice, or similar, for the management of apiaries in cotton growing areas and to develop procedures for the use of honey bees for pollination of cotton crops. The group, which most recently met in February 2008, also intends to develop a network and data bases of cotton growers and beekeepers.

Key points of the current draft Code of Practice are:

- Beekeepers are required to notify the presence of their apiaries to persons and authorities (such as cotton growers, pest management consultants, and aerial or ground pesticide applicators), likely to be involved in applying pesticides within a 8 km radius of their apiaries.
- Beekeepers should be notified at least 48 h prior to pesticide applications to provide them the opportunity to move their hives to sheltered areas away from crops (at least 8 km) until the residual toxicity of the pesticide has diminished.
- Growers/applicators/consultants should choose the pesticide with the lowest hazard rating to bees, particularly those with the shortest residual effect. They should also select the most suitable pesticide formulation (e.g. avoiding microencapsulated forms) and select ground application, if possible, rather than aerial application particularly when close to apiaries. They are recommended to consider time of application, when short-life residue pesticides could be applied in late evening.

The results of my thesis will be reported to this group, to assist in the further drafting of the guidelines.

There is no evidence to suggest that the toxins in Bt cotton, themselves, pose an insecticidal risk to non-target arthropods (Naranjo, 2005; Head *et al.* 2005; Whitehouse *et al.*, 2005; Mansfield *et al.*, 2006; Sharma & Pampathy, 2006), including honeybees (Malone, 2004).

A second important issue related to honeybees and transgenic Bt cotton is the gene flow to conventional crops. In my investigation, in a field containing both conventional and transgenic Bt cotton, 1 km from an apiary of 32 hives (and thus with a high bee activity within the vicinity), I recorded a gene flow of 1.67% over a distance of 16 m. This is much higher than previously recorded, probably because these earlier data were collected in a background of much lower bee activity. Thus, the presence of large numbers of honeybees such as may occur in a deliberate attempt to increase cotton pollination may increase gene flow to conventional cotton or related plant species. This issue has been recognized by the Australian Office of the Gene Technology Regulator (OGTR), who, under the Gene Technology Act 2000 has recently initiated the Cotton Gene Flow Study in Australia, to assess gene flow under conditions of high pollinator activity (2.5 colonies / ha) (Anon, 2007c). It should be noted that, based on my work and that of most other researchers (except Rhodes, 2002: see Table 1.3), for effective pollination of cotton, a higher bee stocking rate than that envisaged in the Gene Flow Study would be required. What might occur with other transgenic cottons, such as Vip (Vegetable Insecticidal Protein) cotton (Estruch *et al.*, 1996), is yet to be determined, although the levels of pollen (gene) flow should be similar.

Following the introduction of *A. mellifera* into Australia in 1822 (Paton, 1996), this country has a high feral (wild) honeybee population, and incidental pollination occurs in many crops (Brous & Keogh, 2008), avoiding the cost for pollination by managed hives. However, Australia is the only major beekeeping country which is free from varroa mite, *Varroa destructor* (= *jacobsoni*) Anderson & Trueman. This parasite poses the single most important threat to Australia's beekeeping industry, as well as to plant based industries reliant on pollination (Anon, 2008c). In the event of varroa mite entering Australia, it would cause a major decline in feral and managed honeybee populations

(Gunnigham *et al.*, 2002) as has occurred most recently in New Zealand (Stevenson *et al.*, 2002). This would create intense competition for managed beehives, which would initially be sought by the industries who are totally reliant on pollination, and who can pay the highest price, such as almonds and melons. Beekeepers would still need to build up their hives in late winter and spring and after bees have been pollinating crops with poor melliferous qualities. Under these circumstances, it is unclear whether honeybees would be regularly used for cotton pollination, despite the advantages of doing so.

Another possible alternative for pollination of crops, including cotton, is the utilization of Australian native bee species. These are more likely to be tolerant of varroa mite. I recorded the megachilid bee, *L. rubricatus*, present in cotton in both years of my field trials at Narabri, although in low numbers. This species is found in NSW, Qld, Northern Territory and Western Australia (Cockerell, 1929). They are commonly found on flowers of *Hibiscus* spp. (Malvaceae) (Michener, 1965) or *Ipomoea* spp. (Convolvulaceae) (Batley, per. com., 2008), both of which have very large pollen grains of a similar size to cotton. Batley further stated that most specimens in the Australian Museum collection carry such pollen and he believes that the long, widely-spaced hairs of the scopa are an adaptation to foraging on such flowers. In the USA bees of this genus are commonly called cactus bees.

Australia has a number of other species of native bees, many of which are solitary [e.g. the blue-banded bee, *Amegilla holmesi* (Anthophoridae), the teddy bear bee, *Amegilla cingulata* Fabricius, leafcutter bees, *Megachile* spp.], but others are social (e.g. genera *Trigona* and *Austroplebeia*) and stingless, and usually nest inside hollow trees. Two common stingless species, *T. carbonaria* and *T. hockingsi*, have been developed for pollination of commercial horticultural crops (Heard, 1999) for field and greenhouse production. Stingless bees may be able to play a greater role in pollination of some crops, although their much shorter foraging range of 100-400 m (Heard, 1999) compared to 5 km for honeybees, may restrict their use in field crops. The blue-banded bee has also been demonstrated to effectively buzz pollinate crops such as tomatoes (Bell *et al.*, 2006), similar to bumble bees (*Bombus* spp.) and with similar yield increases (Hogendoorn *et*

*al.*, 2006). This is an important finding, because the Australian mainland is free of bumblebees, and there is strong resistance against their introduction (Cunningham *et al.*, 2002). Bumblebees have been reported to be an important pollinator of cotton in the USA (Moffett *et al.*, 1980, 1981; Berger *et al.*, 1988), so it is possible that blue-banded bees, which are communal and not eusocial species, may be able to play a role if efficient techniques for their management can be developed. It has been suggested that provision of nesting sites for native bees, particularly *Lithurgus* spp., around cotton crops would increase their population, and could assist in its pollination (Batley, per. com, 2008). However, all potential pollinating species are likely to be susceptible to the use of fipronil or other pesticides at flowering.

Apart from exotic pests and diseases, some of the most serious issues threatening the beekeeping industry in Australia are droughts, bushfires (which destroy many potential honey flora), and logging of eucalyptus forests, Australia's major honey producing flora, for timber or for land clearing (Cunningham *et al.*, 2002). The retention of melliferous resources is one of the key 2007-8 research and development issues for the Australian honeybee industry (Anon, 2008c).

Probably the biggest single influence on bee nutrition, and hence on honey production, is rainfall. This even holds true for the tropical north of Australia where below average rainfall in the wet season usually results in poor honey crops in the following dry season. As well as the amount of rain, its seasonal distribution is equally important. Autumn flowering trees such as belbowrie, *Melaleuca quinquenervia*, or grey gum, *Eucalyptus punctata* var. *punctata*, produce best if the weather at flowering is warm and dry, and humid weather can cause serious reductions in hive populations. While pollination services are developing rapidly in Australia, the majority of apiarists still derive their income from honey production (Anon, 2008b).

The predictions for climate change in Australia suggest that annual average temperatures over most of Australia will rise by 0.4-2.0° C by 2030, and that annual average rainfall in the south east predicated decrease (range -10 to + 5%) over the same period (Whetton,

2001). Australia is currently in the middle of a prolonged drought period, and irrigation water is at a premium. Many irrigation farmers, particularly those in the Murray-Darling River Basin, where cotton is grown, have been unable to receive the water allocated to them. The area of cotton grown in Australia decreased by 50% between 2005-6 and 2006-7 (Anon, 2008a). In the event of an even drier future, the viability of the cotton industry is under threat.

Under these circumstances, application of my findings in Australia may be academic. Never-the-less, my findings are applicable for many other countries who grow Bt, and even conventional, cotton.

## **7.2 FUTURE WORK**

The findings of this thesis raise a number of issues that require further investigation:

- The identification of an alternative pesticide to fipronil which is more bee-friendly.
- The indirect effects of genetic modification of cotton on its attractiveness to bees and other beneficial arthropods, particularly via the production and composition of the extrafloral nectary secretions.
- The reasons why cotton pollen is rejected by honeybees, and methods to increase its attractiveness.
- The assessment of the risk of gene flow from transgenic Bt cotton, particularly in the presence of high honeybee numbers, and the determination of adequate buffer zones for Australia under these conditions.
- Assessment of the efficacy of QMP and other bee attractants for cotton under a range of Australian conditions.
- Biology and ecology of pollen beetles, particularly in cotton-growing regions, and within cotton crops.
- A more comprehensive assessment of the effects of fipronil, its residues and contaminated pollen and nectar on pollinators, particularly honeybee workers and brood, under field conditions.

### **7.3 FINAL CONCLUSIONS**

Honeybees are the most important pollinators in transgenic Bt cotton in Australia, and can increase cotton lint yield by up to one third. However, as it appears there are insufficient feral honeybees and native pollinators to achieve adequate flower visitation rates and subsequent increases in cotton lint yield, managed hives are required. Current plant protection practices in cotton, using highly toxic insecticides, severely limit the use of honeybees, and thus their benefits. Less toxic and less residual insecticides are required to increase cooperation between the beekeeping and cotton growing industries.

There remain opportunities for benefits for both apiarists and cotton farmers, but only if beekeeping and cotton farming can develop and implement strategies to co-exist.



## REFERENCES

- Abbott WS.** 1925. A method of computing the effectiveness of an insecticide. *Journal of Economic Entomology* 18: 265-267.
- Abreu M.** 1992. Food use of pollen in relation to human nutrition. *Alimentaria* 235: 45-46.
- Allard HA.** 1911. Preliminary observations concerning natural crossing in cotton. *American Breeding Magazine* 1: 247-261.
- Allen MD, Jeffree EP.** 1956. The influence of stored pollen and of colony size on the brood rearing of honeybees. *Annals of Applied Biology* 44: 649-656.
- Al-Tikrity WS, Benton AW, Hillman RC, Clarke WW Jr.** 1972. The relationship between the amount of unsealed brood in honeybee colonies and their pollen collection. *Journal of Apicultural Research* 11: 9-12.
- Ambrose JT, Schulteis JR, Bambara SB, Mangum W.** 1995. An evaluation of selected commercial bee attractants in the pollination of cucumbers and watermelons. *American Bee Journal* 135: 267-272.
- Andeada AC, Telleria MC.** 2005. Pollen collected by honeybees (*Apis mellifera* L.) from south of Calden district (Argentina): botanical origin and protein. *Grana* 44: 115-122.
- Anderson LD, Atkins EL.** 1968. Pesticide usage in relation to beekeeping. *Annual Review of Entomology* 13: 213-238.
- Anon.** 1931. Thrips infestation. *The Australian Beekeeper* 33: 130-131.
- Anon.** 1995a. Cotton: the crop and its agrochemicals market. Allen Woodburn Associates Ltd./ Managing Resources Ltd.
- Anon.** 1995b. Atelier international fipronil/lutte antiacridienne. Lyon 3-5 May 1995. Unpublished report. Rhone-Poulenc Agrochimie, Lyon, France.
- Anon.** 1998. OECD guidelines for testing of chemicals, honeybees, acute oral and contact toxicity test; OECD 213 and 214.
- Anon.** 1999. Australian Commodity Statistics 1999, Australian Bureau of Agricultural and Resource Economics (ABARE), Canberra.
- Anon.** 2000. Base de données sur les substances actives phytopharmaceutiques: fipronil. Institut National de la Recherche Agronomique, Paris, France. <http://www.inra.fr/agritoxhttp/php/fiches.php>. (Query for fipronil.)
- Anon.** 2002. Liste des substances actives. Institut National de la Recherche Agronomique, Paris, France. <http://www.inra.fr/agritox>.
- Anon.** 2004. Bollgard II – the new generation in GM cotton. <http://www.csiro.au/index.asp?type=feq&id=Bollgard&stylesheet=divisionFaq>.
- Anon.** 2005a. Cotton classification results: understanding the data. USDA–agricultural Marketing Service (AMS). <http://www.ams.usda.gov/cotton/understand>.
- Anon.** 2005b. Pesticide toxicity to bees. [http://en.wikipedia.org/wiki/Pesticide\\_toxicity\\_to\\_bees](http://en.wikipedia.org/wiki/Pesticide_toxicity_to_bees).
- Anon.** 2006a. Nufarm Australia Limited Laverton North, Victoria 3026.
- Anon.** 2006b. The WHO recommended classification of pesticides by hazard and guidelines to classification 2004. World Health Organization. [http://www.who.int/ipcs/publications/pesticides\\_hazard\\_rev\\_3.pdf](http://www.who.int/ipcs/publications/pesticides_hazard_rev_3.pdf).

- Anon.** 2007a. Australian Commodity Statistics June 2007, Australian Bureau of Agricultural and Resource Economics (ABARE), Canberra.  
[http://www.abareconomics.com/interactivative/ac\\_june07/htm/cotton.htm](http://www.abareconomics.com/interactivative/ac_june07/htm/cotton.htm).
- Anon.** 2007b. Crop Pollination Association Inc. 15th Annual Conference, Maryborough, Victoria, Australia.
- Anon.** 2007c. Request for tender, cotton gene flow study in Australia. Department of Health and Ageing, ABN 83605426759.
- Anon.** 2008a. Cotton area, yield, production. Foreign Agricultural Services: U. S. Department of Agriculture. <http://www.fas.usda.gov/cotton/circular/Current.htm>.
- Anon.** 2008b. Best practice guidelines for management of apiaries in cotton growing areas. Report on Cotton Industry and Beekeeping Industry Meeting. Tamworth, February 20, 2008.
- Anon.** 2008c. Honeybee research program. [www.rirdc.gov.au/07-180.pdf](http://www.rirdc.gov.au/07-180.pdf) accessed 29/05/2008.
- Anon.** 2008d. The classification of cotton. USDA–Agricultural Marketing Service (AMS). Agriculture Handbook 566.  
<http://www.cottoninc.com/ClassificationofCotton/?Pg=4#Classification>.
- Atallah MA, Zeutoun ZA, Hassan AR.** 1998. The relative toxicity of some synthetic pyrethroid and carbamate insecticides to honeybees (*Apis mellifera* L.) in the field. Proceedings of 14<sup>th</sup> international Conference on Apiculture in Tropical Climates, Cairo, Egypt, 6-10 November 1998. International Bee Research Association, London, UK. 218-223.
- Atkins EL.** 1958. Laboratory methods of testing insecticides on bees. *Annals of the Entomological Society of America* 5-12.
- Atkins EL, Anderson LP, Greywood EA.** 1972. Research on the effect of pesticides on honeybees. *American Bee Journal* 112: 387-389, 426-429.
- Atkins EL, Kellum D.** 1986. Comparative morphogenetic and toxicity studies on the effect of pesticides on honeybee brood. *Journal of Apicultural Research* 25: 242-255.
- Avetisyan G.** 1958. Bees- the cotton farmers` helper. *Indian Bee Journal* 20: 28-29.
- Barker HG, Barker I.** 1971. Nectar constitution and pollinator-plant coevolution. In: Gilbert LE, Raven PA (eds). Animal and Plant Coevolution. University of Texas, Austin, Texas. 100-140.
- Barker RJ.** 1971. The influence of food inside the hive on pollen collection by a honeybee colony. *Journal of Apicultural Research* 10: 23-26.
- Barnett AE, Charlton AJ, Fletcher MR.** 2007. Incidents of bee poisoning with pesticides in the United Kingdom, 1994-2003. *Pest Management Science* 63: 1051–1057.
- Barrow.** 1981. A new concept in assessing cotton pollen germinability. *Crop Science* 21: 441-443.
- Bartelt RJ, Dowd PF, Vetter RS, Shorey HH, Baker TC.** 1992. Responses of *Carpophilus hemipterus* (Coleoptera: Nitidulidae) and other sap beetles to the pheromone of *C. hemipterus* and host related coattractants in California field tests. *Environmental Entomology* 21: 1143–1153.

- Bartelt RJ, James DG.** 1994. Aggregation pheromones of Australian sap beetle, *Carpophilus davidsoni* (Coleoptera: Nitidulidae). *Journal of Chemical Ecology* 20:3207–3219.
- Bartelt RJ, Vetter RS, Carlson DG, Baker TC.** 1994. Responses to aggregation pheromones for five *Carpophilus* species (Coleoptera: Nitidulidae) in a California date garden. *Environmental Entomology* 23: 1534–1543.
- Bartelt RJ, Weaver DK, Arbogast RT.** 1995. Aggregation pheromone of *Carpophilus dimidiatus* (F.) (Coleoptera: Nitidulidae) and responses to *Carpophilus* pheromones in South Carolina. *Journal of Chemical Ecology* 21: 1763–1779.
- Beach JH.** 1982. Beetle pollination of *Cyclanthus bipartitus* (Cyclanthaceae). *American Journal of Botany* 69: 1074-1081.
- Beasley CA.** 1975. Developmental morphology of cotton flowers and seed as seen with the scanning electron microscope. *American Journal of Botany* 62: 584-592.
- Beath DN.** 1996. Pollination of *Amorphophallus johnsonii* (Araceae) by carrion beetles (*Phaeochrous amplus*) in a Ghanaian rain forest. *Journal of Tropical Ecology* 12: 409-418.
- Bell MC, Spooner-Hart RN, Haigh AM.** 2006. Pollination of greenhouse tomatoes by the Australian bluebanded bee *Amegilla (Zonamegilla) holmesi* (Hymenoptera: Apidae). *Journal of Economic Entomology* 99: 437-442.
- Belletti A, Zani A.** 1981. A bee attractant for carrots grown for seed. *Sementi Elette* 27: 23-27. [In Italian]
- Benedek P, Nagy C.** 1996. Flower constancy of pollinating honeybees on some fruit tree species. *Acta Hort* 423: 65-72.
- Bennett GJ.** 1993. Pollination is big business in Arizona. *Bee Culture* 121: 646-649.
- Berger LA, Vaissiere BE, Moffett JO, Merritt S.** 1988. *Bombus* spp. (Hymenoptera: Apidae) as pollinators of male-sterile upland cotton on the Texas high plains. *Environmental Entomology* 17: 789-794.
- Betz FS, Hammond BG, Fuchs RL.** 2000. Safety and advantages of *Bacillus thuringiensis* protected to control insect pests. *Regulatory Toxicology and Pharmacology* 32: 165-173.
- Bienkowska M, Pohorecka K.** 1996. Results of pollen trapping dependent on the size of holes in the insert scraping pollen pellets [Polish] Abstract (Eng.). *Pszczelnicze Zeszyty Naukowe* 40: 95-101.
- Blanche R, Cunningham S.** 2005. Rain forest provides beetles for *Atemoya* crops. *Journal of Economic Entomology* 98: 1193-1201.
- Blight MM, Smart EL.** 1999. Influence of visual cues and isothiocyanate lures on capture of pollen beetle *Meligethes aeneus* in field traps. *Journal of Chemical Ecology* 25: 1501-1516.
- Block G, Sinha R, Gridley G.** 1994. Collection of dietary-supplement data and implication for analysis. *American Journal of Clinical Nutrition* 59: 234-239.
- Bobé A, Coste CM, Cooper JF.** 1997. Factors influencing the adsorption of Fipronil on soils. *Journal of Agricultural and Food Chemistry* 45: 4861-4865.
- Bobé A, Meallier P, Cooper JF, Coste C M.** 1998. Kinetics and mechanisms of abiotic degradation of fipronil (hydrolysis and photolysis). *Journal of Agricultural and Food Chemistry*. 46: 2834–2839.

- Bodenheimer FS, Ben-Nerya A.** 1937. One year studies on the biology of the honey-bee in Palestine. *Annals of Applied Biology* 24:385-403.
- Bonvehi JS, Jorda RE.** 1997. Nutrient composition and microbiological quality of honeybee-collected pollen in Spain. *Journal of Agricultural and Food Chemistry* 45: 725-732.
- Brous D, Keogh R.** 2008. Pollination Australia: biosecurity risk management. RIRDC Pub. No. 08/054.
- Brown NB, Ware JO.** 1958. Cotton. McGraw-Hill, New York.
- Buchmann SL, Shipman CW.** 1990. Pollen harvesting rates for *Apis mellifera* L. on *Gossypium* (Malvaceae) flowers. *Journal of Kansas Entomological Society* 63: 92-100.
- Burgett M, Fisher GC.** 1979. An evaluation of Beeline as a pollinator attractant on red clover. *American Bee Journal* 119: 356-357.
- Búrquez A, Sarukhan J, Pedroza AL.** 1987. The biology of a primary rain forest palm, *Astrocaryum mexicanum* Liebm. *Botanical Journal of the Linnean Society* 31: 161-174.
- Busvine JR.** 1971. A critical review of the techniques for testing insecticides. Commonwealth Agricultural Bureaux, UK.
- Butler GD, Loper GM, McGregor SE, Webster JL, Margolis H.** 1972. Amounts and kinds of sugars in the nectar of cotton (*Gossypium* spp.) and the time of their secretion. *Agronomy Journal* 64: 364-368.
- Butts KM.** 1991. Bee attractant: improving strawberry quality? *Citrus and Vegetable Magazine* 55: 16-17.
- Cabras P, Martini MG, Floris I, Spanedda L.** 1994. Residues of cymiazole in honey of honey bees. *Journal of Apiculture Research* 33: 83-86.
- Cale GH.** 1968. Pollen gathering relationship to honey collection and egg-laying in honeybees. *Journal Apicultural Research* 108: 8-9.
- Camazine S.** 1990. From individual to colony-level behavior in honeybees: the regulation of pollen foraging. In: Veeresh GK, Mallik B, Viraktamath CA (eds.). Social insects and the environment, Proc 11 Int. Congr. IUSI, Oxford & IBH Publ. Co., New Delhi. 566-567.
- Camazine S.** 1993. The regulation of pollen foraging by honey bees: how foragers assess the colony's need for pollen. *Behavioral Ecology and Sociobiology* 32: 265-273.
- Cauich O, Quezada-Euan JG, Macias-Macias JO, Oregel VR, Medina-Peralta S, Parra-Tabla VP.** 2004. Behavior and pollination efficiency of *Nannotrigona perilampoides* (Hymenoptera: Meliponini) on greenhouse tomatoes (*Lycopersicon esculentum*) in subtropical Mexico. *Journal of Economic Entomology* 97: 476-481.
- Chalmers WT.** 1980. Fish meals as pollen-protein substitutes for honeybees. *Bee World* 61: 89-96.
- Chambers SR.** 1980. Management of honeybee colonies on pollen trap. *Australian Beekeeper* 81: 208-209.
- Chang H, Nguyen C.** 2002. Elasticity of demand for Australian cotton in Japan. *The Australian Journal of Agricultural and Resource Economics* 46: 99-113.

- Chauzat MP, Faucon JP, Martel AC, Lachaize J, Cougoule N, Aubert M.** 2006. A survey of pesticide residues in pollen loads collected by honey bees in France. *Journal of Economic Entomology* 99: 253-262.
- Clemson A.** 1985. Honey and pollen flora. Inkata Press, Department of Agriculture of N.S.W., Australia.
- Cockerell, TDA.** 1929. Bees from the Australian region. *American Museum Novitates* 346: 1-18.
- Coffey MF, Breen I.** 1997. Seasonal variation in pollen and nectar sources of honeybee in Ireland. *Journal of Apicultural Research* 36: 63-76.
- Colin ME, Bonmatin JM, Moineau I, Gaimon C, Burn S, Vermandere JP.** 2004. A method to quantify and analyse the foraging activity of honey bees: relevance to sublethal effects induced by systemic insecticides. *Archives of Environmental Contamination and Toxicology* 47: 387-395.
- Colville J, Picker MD, Cowling RM.** 2002. Species turnover of monkey beetles (Scarabaeidae: Hopliini) along environmental and disturbance gradients in the Namaqualand region of the succulent Karoo, South Africa. *Biodiversity and Conservation* 11: 234-264.
- Conner AJ, Glare TR, Nap JP.** 2003. The release of genetically modified crops into the environment. Part II. Overview of ecological risk assessment. *The Plant Journal* 33: 19-46.
- Constable GA, Reid PE, Thomson NJ.** 2001. Approaches utilized in breed and development of cotton cultivars in Australia. *In: Jenkins JN, Saha S (eds.). Genetic improvement of cotton: emerging technologies.* USDA. 1-16.
- Cook VA.** 1985. Trapping pollen from the bee. *Grower* 103:9, 2.
- Costa G, Testolin R, Vizzotto G.** 1993. Kiwifruit pollination: an unbiased estimate of wind and bee contribution. *New Zealand Journal of Crop and Horticultural Sciences* 21: 189-185.
- Cox C.** 2005. Fipronil. *Journal of Pesticide Reform* 25: 10-25.
- Craig P, Steven JD.** 2006. Anther cap retention prevents self-pollination by elaterid beetles in the South Africa orchid *Eulophia foliosa*. *Annals of Botany* 97: 345-355.
- Crailsheim K, Schneider LH, Hrassnigg N, Buchlmann G, Brosch U, Gmeinbauer R, Schoffmann B.** 1992. Pollen consumption and utilization in worker honeybees (*Apis mellifera carnica*): dependence on individual age and function. *Journal of Insect Physiology* 38: 409-419.
- Crane E.** 1975. Honey: a comprehensive survey. Heinemann, London: International Bee Research Association.
- Croft BA.** 1990. Arthropoda biological control agents and pesticides. New York: Wiley.
- Crowson RA.** 1988. Meligethinae as possible pollinators (Coleoptera: Nitidulidae). *Entomologia Generalis* 14: 61-62.
- Cruden RW, Hermann SM, Peterson S.** 1983. Patterns of nectar production and plant animal coevolution. *In: Bentley B, Elias T (eds.). The biology of nectarines.* Columbia University Press, New York. pp 126-152.
- Cundill PR.** 1986. A new design of pollen trap for modern pollen studies. *Journal of Biogeography* 13: 83-98.

- Cunningham SA, FitzGibbon F, Heard TA.** 2002. The future of pollinators in Australian agriculture. *Australian Journal of Agricultural Research* 53: 893-900.
- Currie RW, Winston ML, Slessor KN.** 1992a. Effect of synthetic queen mandibular pheromone sprays on pollination of fruit crops by honey bee (Hymenoptera: Apidae). *Journal of Economic Entomology* 85: 1293-1299.
- Currie RW, Winston ML, Slessor KN.** 1992b. Effect of synthetic queen mandibular pheromone sprays on honey bee (Hymenoptera: Apidae) pollination of berry crops. *Journal of Economic Entomology* 85: 1300-1306.
- Dadant CC.** 1992. Beekeeping equipment. In: Graham JM (ed.). *The hive and the honey bee* Hamilton, III: Dadant & Sons. pp 539-568.
- Dafni A, Bernhardt P, Shmida A, Ivri Y, Breenbaum S.** 1990. Red bowl-shaped flowers-convergence in the Mediterranean and beetle pollination. *Israel Journal of Botany* 39: 81-92.
- Danka RG.** 2005. High levels of cotton pollen collection observed for honey bees (Hymenoptera: Apidae) in South-Central Louisiana. *Journal of Entomological Science* 40: 316-326.
- Davis AR.** 1989. The study of insecticide poisoning of honeybee brood. *Bee World* 70: 163-174.
- De Groot AP.** 1953. Protein and amino acid requirements of the honey bee (*Apis mellifera* L.). *Physiologia comparata et D'Oecologia* 3: 197-285.
- Decourtye A.** 2002. Etude de l'impact des produits phytopharmaceutiques sur la survie et l'apprentissage associatif chez l'abeille domestique (*Apis mellifera* L.). PhD Thesis, University Paris X.I., d'Orsay.
- Decourtye A, Armengaud C, Renou M, Devillers J, Cluzeau S, Gauthier M.** 2004. Imidacloprid impairs memory and brain metabolism in the honeybee (*Apis mellifera* L.) *Pesticide Biochemistry and Physiology*. 78, 83–92
- Decourtye A, Devillers J, Genecque E, Menach Le, Budzinski H, Cluzeau S, Pham-Delegue MH.** 2005. Comparative sublethal toxicity of nine pesticides on olfactory learning performances of the honeybee *Apis mellifera*. *Archives of Environmental Contamination Toxicology* 48: 242-250.
- Delaplane k, Mayer D.** 2000. Crop pollination by bees. University Press: Cambridge, UK.
- Desneux N, Decourtye A, Delpuech JM.** 2007. The sublethal effects of pesticides on beneficial arthropods. *Annual Review of Entomology* 52: 81-106.
- Devillers J, Decourtye A, Budzinski H, Pham-delegue MH, Cluzeau S, Maurin G.** 2003. Comparative toxicity and hazards of pesticide to *Apis* and non-*Apis* bees: a chemometrical study. *SAR and QSAR in Environmental Research* 14: 389-404.
- Devillers J, Pham-délégué MH.** 2002. Honeybees: estimating the environmental impacts of chemicals. Taylor & Francis, London.
- Diaz-losada E, Ricciardelli GD, Pilar SAA, Otero M.** 1998. The possible use of honeybee pollen loads in characterizing vegetation. *Grana* 37: 155-163.
- Dieringer G, Cabrera RL, Lara M, Loya L, Reyes-Castillo P.** 1999. Beetle pollination and floral thermogenicity in *Magnolia tamaulipana* (Magnoliaceae). *International Journal of Plant Science* 160: 64-71.
- Dimou M, Thrasyvoulou A.** 2006. Efficient use of pollen traps to determine the pollen flora used by honey bee. *Journal of Apicultural Research* 45: 42-46.

- Dimou M, Thrasyvoulou A.** 2007. A comparison of three methods for assessing the relative abundance of pollen resources collected by honey bee colonies. *Journal of Apicultural Research* 46: 144-148.
- Dolan L, Poethig RS.** 1991. Genetic analysis of leaf development in cotton. *Development Supplement* 1: 39-46.
- Doull KM.** 1971. An analysis of bee behaviour as it relates to pollination. *American Bee Journal* 111: 266-73, 203-3, 340-41.
- Doull KM.** 1973. Relationships between consumption of a pollen supplement, honey production and broodrearing in colonies of honeybees, *Apis mellifera* L. I. *Apidologie* 11: 4, 361-365.
- Doull KM.** 1980a. Relationships between pollen, broodrearing and consumption of pollen supplement by honeybees. *Apidologie* 4: 4, 285-293.
- Doull KM.** 1980b. Relationships between consumption of a pollen supplement, honey production and broodrearing in colonies of honeybees, *Apis mellifera* L. II. *Apidologie* 11: 4, 367-374.
- Dowd PF, Bartelt RF.** 1991. Host-derived volatiles as attractants and pheromone synergists for driedfruit beetle, *Carpophilus hemipterus*. *Journal of Chemical Ecology* 17: 285-308.
- Doyle B, Reeve I, Coleman M.** 2005. A survey of cotton growers' and consultants' experience with Bollgard in the 2004-2005 season. Cotton Research, Institute for Rural Futures, University of New England.
- Dreller C, Page R, Fondrk KM.** 1999. Regulation of pollen foraging in honeybee colonies: effects of young brood, stored pollen, and empty space. *Behavioral Ecology and Sociobiology* 45: 227-233.
- Duff SR, Furgala B.** 1986. Pollen trapping honey bee colonies in Minnesota. *Journal of Apicultural Research* 25: 758-757.
- Dukas R, Morse DH.** 2003. Crab spiders affect flower visitation by bees. *Oikos* 101: 157-163.
- Eaton FM.** 1955. The physiology of the cotton plant. *Annual Review of Plant Physiology* 6:299-328.
- Eaton FM, Ergle DR.** 1953. Effects of shade and partial defoliation on carbohydrate levels and the growth, fruiting and fiber properties of cotton plants. *Plant Physiology* 26: 39-49.
- Eckert CD, Winston ML, Ydehnberg RC.** 1994. The relationship between population size, amount of brood, and individual foraging behavior in the honey bee, *Apis mellifera* L. *Oecologia* 97: 248-255.
- Eckert JE.** 1942. The pollen required by a colony of honeybee. *Journal of Economic Entomology* 35: 309-311.
- Eichers TR.** 1981. Use of pesticides by farmers. In: Pimentel D (ed.). Handbook of pest management in agriculture. Volume II. CRC Press. Boca Raton, Fla.
- Eisikowitch D, Loper GM.** 1984. Some aspects of flower biology and bee activity on hybrid cotton in Arizona, USA. *Journal of Apiculture Research* 23: 243-248.
- El-Banby MA, El-Sherif ME, Shatla MA.** 1985. Productivity and chemical analysis of nectar and its mechanisms of flow in cotton flowers, *Gossypium barbadense*. Proceedings, 15<sup>th</sup> International Apiculture Congress of Apimondia, Japan.

- Elfawal MA, Bishr MA, Hassoub EK.** 1976. Natural cross pollination in Egyptian cotton (*Gossypium barbadense* L.). *Journal of Agricultural Science* 86: 205-209.
- El-Khashab AM.** 1967. The practical methods for protecting honeybees from insecticides. MSc Thesis. Faculty of Agriculture, Cairo University.
- Elmstrom GW, Maynard DN.** 1990. Attraction honey bees to watermelon with bee attractant. *Proceedings of the Florida State Horticultural Society* 103: 130-133.
- El-Sarrag MS, Ahmed HM, Siddig MA.** 1993. Insect pollinators of certain crops in the Sudan and the effect of pollination on seed yield and quality. *Journal of King Saud University, Agriculture Sciences* 5: 253-262.
- Endress PK.** 1994. Diversity and evolutionary biology of tropical flowers. Cambridge University Press, Cambridge.
- Erickson E, Buchmann SL.** 1983. Electrostatics and pollinating. *In: Jones CE, Little RJ* (eds.). *Handbook of experimental pollination biology*. Van Nostrand-Ran, New York. 173-184.
- Estesen BJ, Buck NA, Waller GD, Taylor KS, Mamood A.** 1992. Residual life and toxicity to honey bees (*Apis mellifera* L.) of selected insecticides applied to cotton in Arizona. *Journal of Economic Entomology* 85: 700-709.
- Estruch JJ, Warren GW, Mullins MA, Nye GJ, Craig JA, Koziel MG.** 1996. Vip3A, a novel *Bacillus thuringiensis* vegetative insecticidal protein with a wide spectrum of activities against Lepidopteran insects. *Proceedings of the National Academy of Sciences of the United States of America* 93: 5389-5394. doi:10.1073/pans.93.11.5389.
- Evans JW.** 1932. The bionomics and economic importance of *Thrips imaginis* Bagnall. Pamphlet of the Council for Scientific and Industrial Research, Australia. 30: 1-48.
- Eveleigh R, Kay A, Marshall J, Constable G, Morrison I.** 1999. Quality considerations with Australian cotton. Grower Information, Cotton Seed Distributors, Wee Waa, NSW, Australia.
- Farrell T.** 2007. Cotton pest management guide. p 51. CRC, Narrabri.
- Ferris SD, Sage RD, Huang C, Nielsen M, Ritte U, Wilson AC.** 1983. Flow of mitochondrial DNA across a species boundary. *Proceedings of the National Academy of Sciences* 80: 2290-2294.
- Fewell JH, Winston ML.** 1992. Colony state and regulation of pollen foraging in the honey bees (*Apis mellifera* L.). *Behavioral Ecology and Sociobiology* 30: 387-393.
- Filmer RS.** 1932. Brood area and colony size as factors in activity of pollinating units. *Journal of Economic Entomology* 25: 336-343.
- Fitt G.** 2000. An Australian approach to IPM in cotton: integrating new technologies to minimise insecticide dependence. *Crop Protection* 19: 793-800.
- Fitt G.** 2004. Implementation and impact of transgenic Bt cottons in Australia. *In: Cotton production for the new millennium, Proceedings of the Third World Research Conference*. 9-13 March 2003, Cape Town, South Africa. pp 371-381. (Agricultural Research Council Institute for Industrial Crops: Pretoria, South Africa).



- Flint ML.** 1996. Integrated pest management for cotton in the western region of the United States. 2<sup>nd</sup> ed. University of California, Division of Agriculture and Natural Resource.
- Forster IW.** 1966. Pollen supplement for honey bee colonies. *New Zealand Beekeeper* 28: 14-21.
- Forster IW.** 1968a. Pollen supplement for honey bee colonies. *New Zealand Beekeeper* 30: 2-8.
- Forster IW.** 1968b. Pollen supplement for honey bee colonies. *New Zealand Beekeeper* 30: 16-17.
- Free JB.** 1965. Attempts to increase pollination by spraying crops with sugar syrup. *Journal of Apicultural Research* 4: 61-64.
- Free JB.** 1967. Factors determining the collection of pollen by honeybee foragers. *Animal Behaviour* 15: 134-144.
- Free JB.** 1968a. Dandelion as a competitor to fruit trees for bee visits *The Journal of Applied Ecology* 5: 169-178.
- Free JB.** 1968b. The foraging behaviour of honeybees (*Apis mellifera*) and bumblebees (*Bombus spp.*) on blackcurrant (*Ribes nigrum*), raspberry (*Rubus idaeus*) and strawberry (*Fragaria x Ananassa*) flowers. *The Journal of Applied Ecology* 5: 157-168
- Free JB.** 1968c. The conditions under which foraging honey bees expose their Nasonov gland. *Journal of Apicultural Research* 7: 139-145.
- Free JB.** 1993. Insect pollination of crops. 2<sup>nd</sup> ed. Academic Press, London, UK.
- Free JB, Nancy W, Jay SC.** 1960. The effect on foraging behaviour after moving honeybee colonies to crops before or after flowering has began. *Journal of Economic Entomology* 53: 464-466.
- Free JB, Nuttall PM.** 1968. The pollination of oilseed rape (*Brassica napus*) and the behaviour of bees on the crop. *Journal of agricultural Science* 71: 91-94.
- Free JB, Spencer-Booth Y.** 1963. The foraging area of honey bee colonies in fruit or orchards. *Journal of Horticultural Science* 38: 129-137.
- Free JB, Williams IH.** 1971. The effect of giving pollen supplement to honeybee colonies on the amount of pollen collected. *Journal of Apicultural Research* 10: 87-90.
- Free JB, Williams IH.** 1974. Influence of location of honeybee colonies on their choice of pollen sources. *Journal of Applied Ecology* 11: 925-935.
- Free JB, Williams IH.** 1979. The distribution of insect pests on crops of oil-seed rape (*Brassica napus* L.) and the damage they cause. *Journal of Agricultural Science* 92: 139-149.
- Garcia-Robledo C, Kattan G, Murica C, Quintero-Marin P.** 2004. Beetle pollination and fruit predation of *Xanthosoma daguense* (Araceae) in an Andean cloud forest in Colombia. *Journal of Tropical Ecology* 20: 459-469.
- Gary N.** 1967. A method for evaluating honey bee flight activity at the entrance. *Journal of Economic Entomology* 60: 102-106.
- Gary N, Lorenzen K.** 1988. Substage illumination device for restraining flight of honey bees (Hymenoptera: Apidae) and positively phototactic insects. *Annals of the Entomological Society of America* 81: 700-703.

- Gazit S, Galon I, Podoler H.** 1982. The role of nitidulid beetles in natural pollination of annona in Israel. *Journal of the American Society for Horticultural Science* 107: 849-852.
- George AP, Nissen RJ, Ironside DA, Anderson P.** 1989. Effects of nitidulid beetles in natural pollination of fruit set of *Annona* spp. hybrids. *Journal of the American Society for Horticultural Science* 39: 289-299.
- Gianessi LP, Carpenter JE.** 1999. Agricultural biotechnology: insect control benefits. Washington, DC: National Centre for Food and Agricultural Policy.
- Gibernau M, Barabe D, Cerdan P, Dejean A.** 1999. Beetle pollination of *Philodendron solimoesense* (Araceae) in French Guiana. *International Journal of Plant Science* 160: 1135-1143.
- Glushkov NM.** 1960. Increasing the cotton crop by saturation bee pollination. *Pchelovostvo Mosk* (English summary) 37: 29-30.
- Glynn JGB, Connell JU.** 1954. Studies of the toxicity to worker honeybee (*Apis mellifera* L.) of certain chemicals used in plant protection. *Annual of Applied Biology* 41: 271-279.
- Goebel R.** 1984. Honey bees for pollination. *The Australian Beekeeper* 85: 166-174.
- Goldblatt P, Bernhardt P, JM Manning.** 1998. Pollination of petaloid geophytes by monkey beetles (Scarabaeidae: Rutlinae: Hopliini) in Southern Africa. *Annals of Missouri Botanical Garden* 85: 215-230.
- Goldblatt P, Manning JC.** 1996. Aristeas and beetles pollination. *Veld & Flora* 82: 17-19.
- Goldblatt P, Manning JC.** 2006. Radiation of pollination systems in the Iridaceae of sub-Saharan Africa. *Annals of Botany* 97: 317-344.
- Goodman RD.** 1974. The rate of brood rearing and effect of pollen trapping on honey bee colonies. *The Australian Beekeeper* 76: 39-41.
- Goodwin RM.** 1986. Increased kiwifruit pollen collection after feeding sugar syrup to honey bees within their hive. *New Zealand Journal of Crop and Horticultural Science* 14: 57-61.
- Goodwin RM.** 1997. Feeding sugar syrup to honey bee colonies to improve pollination: a review. *Bee World* 78: 56-62.
- Goodwin RM, Houten AT, Perry JH.** 1994. Effect of feeding pollen substitute to honey bee colonies used for kiwifruit pollination and honey production. *New Zealand Journal of Crop and Horticultural Science* 22: 459-462.
- Goodwin RM, Perry IH.** 1992. Use of pollen traps to investigate the foraging behavior of honey bee colonies in kiwifruit orchards. *New Zealand Journal of Crop and Horticultural Science* 20: 23-26.
- Gordon J, Davis L.** 2003. Valuing honeybee pollination. RIRDC Project, No. CIE-15A, Pub. No. 03/077.
- Gori DF.** 1983. Post-pollination phenomena and adaptive floral changes. In: Jones CE, Little RJ (eds.). Handbook of experimental pollination biology. New York: Van Nostrand Reinhold. pp 31-45.
- Gottsberger G.** 1989a. Beetle pollination and flowering rhythm of *Annona* spp. (Annonaceae) in Brazil. *Plant Systematics and Evolution* 167: 165-187.

- Gottsberger G.** 1989b. Comments on flower evolution and beetle pollination in genera *Annona* and *Rollinia* (Annonaceae). *Plant Systematics and Evolution* 167: 189-194.
- Gottsberger G.** 1990. Flowers and beetles in the South American Tropics. *Botanica Acta* 103: 360-365.
- Grant V, Connell W.** 1979. The association between *Carpophilus* beetles and cactus flowers. *Plant Systematics and Evolution* 133: 99-102.
- Greenplate JT, Penn SR, Shappley Z, Oppenhuizen M, Mann J, Eeich B, Osborn J.** 2000. Bollgard II efficacy: quantification of lepidopteran activity in a 2-gene product. In: Dugger P, Richter D (eds.). Proceedings, Beltwide Cotton Conference, National Cotton Council, Memphis, TN. 1041-1043.
- Greenplate JT, Turnipseed SG, Sullivan MJ, May OL.** 2001. Treatment thresholds for stink bugs (Hemiptera: Pentatomoidae) in cotton. *Journal of Economic Entomology* 94: 403-409.
- Gregg PC, Del Socorro AP, Hawes A.** 2004. Magnet®: An attract-and-kill formulation for *Helicoverpa armigera* and *H. punctigera* (Lepidoptera: Noctuidae) based on plant volatiles. The 2004 ESA Annual Meeting and Exhibition. [http://esa.confex.com/esa/2004/techprogram/paper\\_14005.htm](http://esa.confex.com/esa/2004/techprogram/paper_14005.htm).
- Grout RA.** 1955. Honey bees make hybrid cotton possible. *American Bee Journal* 95: 10-11.
- Gunasekara AS, Truong T, Goh KS, Spurlock F, Tjeerdema RS.** 2007. Environmental fate and toxicology of fipronil. *Journal of Pesticide Science* 32: 189-199.
- Habeck DH.** 2002. Nitidulidae Latreille 1802. In: Arnett RH, Thomas MC, Skelley PE, Frank JH (eds.). American Beetles Volume 2. CRC Press, Boca Raton, FL. 311-315.
- Hainzl D, Casida JE.** 1996. Fipronil insecticide: Novel photochemical desulfinylation with retention of neurotoxicity. *Proceedings of the National Academy of Sciences* 93: 12764- 12767.
- Hanny B, Loper G, Harvey J.** 1983. Chemical detection of PennCap-M capsules in pollen, and methyl parathion residues in honeybees (*Apis mellifera* L.) and bee products from colonies near Arizona cotton fields treated with PennCap-M. *American Bee Journal* 123: 526-529.
- Hansen LM.** 2004. Economic damage threshold model for pollen beetles (*Meligethes aeneus* F.) in spring oilseed rape (*Brassica napus* L.) crops. *Crop Protection* 23: 43-46.
- Hart T, Nabors R.** 1999. Pollen traps as a method of varroa control. *American Bee Journal* 139: 5, 366-367.
- Haslett J.** 2008. Almond industry expansion-demand for bees, projection, market for almond. 95<sup>th</sup> Annual Conference, NSW Apiarists' Association Inc.
- Hassani AKE, Dacher M, Gauthier M, Armengaud C.** 2005. Effects of sublethal doses of fipronil on the behavior of the honeybee. *Pharmacology Biochemistry and Behavior* 82: 30-39.
- Haydak M.** 1945. Value of pollen substitutes for brood rearing of honeybees. *Journal of Economic Entomology* 38: 484-487.
- Haydak M.** 1970. Honey bee nutrition. *Annual Review of Entomology* 15: 143-156.

- Haynes KF.** 1988. Sublethal effects of neurotoxic insecticides on insect behavior. *Annual Review of Entomology* 33: 149-68.
- Head G, Moar W, Eubanks M, Freeman B, Ruberson J, Hagerty A, Turnipseed S.** 2005. A multiyear, large-scale comparison of arthropod populations on commercially managed *Bt* and non-*Bt* cotton fields. *Environmental Entomology* 34: 1257-1266.
- Heard TA.** 1999. The role of stingless bees in crop pollination. *Annual Review of Entomology* 44: 183-206.
- Hearn AB.** 1975. Ord valley cotton crop: development of a technology. *Cotton Grower Review* 52: 77-102.
- Hector JM.** 1963. Introduction to the botany of field crops. II. Non-cereals. Central News Agency, Johannesburg, pp 814-928.
- Hellmich RL, Kulinovic JM, Rothenbuhler WC.** 1985. Selection for high and low pollen-hoarding honey bees. *Journal of Heredity* 76: 155-158.
- Hellmich RL, Rothenbuhler WC.** 1986. Relationship between different amounts of brood and the collection and the use of pollen by the honey bees (*Apis mellifera*). *Apidologie* 17: 13-20.
- Hemborg SM, Bong WJ.** 2005. Different rewards in female and male flowers can explain the evolution of sexual dimorphism in plants. *Biological Journal of the Linnean Society* 85: 97-109.
- Henderson A, Pardini R, Robello S, Vanin S, Almeida D.** 2000. Pollination of *Bactris* (Palmae) in an Amazon forest. *Brittonia* 52: 160-171.
- Herbert EW, Shimanuki H.** 1980. An evaluation of seven potential pollen substitutes for honey bees. *Journal of Apicultural Research* 19: 349-350.
- Higo HA, Winston ML, Slessor KN.** 1995. Mechanisms by which honey bee (Hymenoptera: Apidae) queen pheromone sprays enhance pollination. *Annals of the Entomology Society of America* 88: 366-373.
- Hinton HE.** 1945. A monograph of the beetles associated with stored products. *Jarrold, Norwich, UK.*
- Hirschfelder H.** 1951. Quantitative untersuchungen sum pollenentragen der bienenvölker [Quantitative investigations on pollen collection by bee colonies]. *Z. Bieneforsch* 1: 67-77.
- Hogendoorn K, Gross CL, Sedgley M, Keller MA.** 2006. Increased tomato yield through pollination by native Australian *Amegilla chlorocyanea* (Hymenoptera: Anthophoridae). *Journal of Economic Entomology* 99: 828-833.
- Hogendoorn K, Steen Z, Schwarz MP.** 2000. Native Australian carpenter bees as a potential alternative to introducing bumblebees for tomato pollination in greenhouses. *Journal of Apicultural Research* 39: 67-74.
- Hoopingarner R, Waller G.** 1992. Crop pollination. In: Graham J (ed.). *The hive and the honey bee*. Dadant & Sons Pub., Hamilton, III. pp 1043-1082.
- Hopkins CY, Jevans AW, Boch R.** 1969. Occurrence of octadeca-trans-2, cis-9, cis-12-trienoic acid in pollen attractive to the honey bee. *Canadian Journal of Biochemistry* 47: 433-436.
- Hossain MS, Williams DG, Mansfield C, Bartelt RJ, Callinan L, Il'ichev AL.** 2006. An attract-and-kill system to control *Carpophilus* spp. in Australian stone fruit orchards *Entomologia Experimentalis et Applicata* 118: 11-19.

- Howpage D.** 1999. Pollination biology of kiwifruit: influence of honey bees, *Apis mellifera* L, pollen parents and pistil structure. PhD thesis, University of Western Sydney, Australia.
- Ibrahim SH, Selim HA.** 1974. Effect of pollen traps on honeybee colonies. *Agricultural Research Review*. 52: 109-114.
- Inouye DW, Gille DE, Dudash MR, Fenster CB.** 1994a. A model and lexicon for pollen fate. *American Journal of Botany* 81: 1517-1530.
- James DG.** 2003. Synthetic herbivore-induced plant volatiles as field attractants for beneficial insects. *Environmental Entomology* 32: 977-982.
- Janki R, Singh P, Prakesh R, Haque MF.** 1968. Floral biology of cotton (*Gossypium* spp.). *Indian Agricultural Science* 38: 528-535.
- Jay SC.** 1986. Spatial management of honey bees on crops. *Annual Review of Entomology* 18: 387-391.
- Jay D, Jay SC.** 1984. Observations of honeybees on Chinese gooseberries (“Kiwifruit”) in New Zealand. *Bee World* 65: 155-166.
- Jaycox ER.** 1963. Confinement of honeybee colonies to avoid pesticide losses. *Journal of Apicultural Research* 2: 43-49.
- Jaycox ER.** 1970. Honey bee queen pheromones and worker foraging behaviour. *Annals of the Entomology Society of America* 63: 222-228.
- Jeffree EP.** 1958. A shape wire grid for estimating quantities of brood and pollen in combs. *Bee World* 39: 115-118.
- Jenkins JN, Saha S.** 2001. Genetic improvement of cotton: emerging technologies. USDA.
- Jimenez JJ, Bernal JL, Nozal MJ, Martini MT, Mayo R.** 2007. Comparative study of sample preparation procedures to determine fipronil in pollen by gas chromatography with mass spectrometric and electron-capture detection. *Journal of Chromatography* 1146: 8-16.
- Johansen CA.** 1977. Pesticides and pollinators. *Annual Review of Entomology* 22: 177-192.
- Johansen CA, Mayer, DF, Eves JD, Kious CW.** 1983. Pesticides and bees. *Environmental Entomology* 12: 1513-1518.
- Johnson SD.** 2004. An overview of plant-pollinator relationships in the South Africa. *International of Tropical Insect Science* 24: 45-54.
- Jones FGW, Jones MG.** 1984. Pests of field crops. 3<sup>rd</sup> ed. Edward Arnold; London, UK.
- Kadar A, Faucon.** 2006. Determination of traces of fipronil and its metabolites in pollen by liquid chromatography with electrospray ionization-tandem mass spectrometry. *Agricultural and Food Chemistry* 54: 9741-9746.
- Kaziev T.** 1960. The influence of bee pollination on cotton quality. *Pchelovodstvo* 37: 33-35.
- Kearney TH.** 1923. Self fertilization and cross fertilization in Pima cotton. Bulletin U.S. Department of Agriculture. No. 1134.
- Kearney TH.** 1924. A hybrid between cotton. *Journal of Heredity* 15: 309-317.
- Keller I, Fluri P, Imdorf A.** 2005. Pollen nutrition and colony development in honey bees: Part I. *Bee World* 86: 3-10.
- Kerby T, Hugie B, Howard K, Bates M, Burgess J, Mahaffey J.** 2000. Fiber quality comparisons among varieties for conventional, Bollgard® and Roundup Ready®

- versions. *In*: Dugger CP, Richter DA (eds.). Proceedings of the Beltwide Cotton Conference Volume (1). Memphis, TN: National Cotton Council of America. pp 1484-1488.
- Kerner A.** 1878. Flowers and their unbidden guests. Kegan Poul; London, UK.
- Kevan PG, Baker HG.** 1983. Insects as flower visitors and pollinators. *Annual Review of Entomology* 28: 407-453.
- Khan M, Baure R.** 2002. Damage assessment, monitoring and action thresholds of stinkbug pests in cotton. *In*: Proceedings of the 11th Australian Cotton Conference, Brisbane, Queensland. Australian Cotton Growers Research Association, pp 395-400.
- Khan MS, Kumari B, Rohilla HR, Kaushik HD, Arora RK.** 2004. Analysis of insecticide residues in honeys from apiary (*Apis mellifera*) and wild honey bee (*Apis dorsata* and *Apis florea*) colonies in India. *Journal of Apiculture Research* 43: 79-82.
- Kirk WDJ.** 1984. Pollen feeding thrips (Insecta: Thysanoptera). *Journal of Zoology* 204: 107-117.
- Kirk WDJ.** 1988. Thrips and pollination biology. *In*: Ananthakrishnan TN, Raman A (eds.). Dynamics of insect-plant interaction. Oxford & IBH; New Delhi, India. 129-135.
- Kirk WDJ, Ali M, Breadmore K.** 1995. The effects of pollen beetles on the foraging behaviour of honey bees. *Journal of Apicultural Research* 34: 15-22.
- Knight RL.** 1935. The effect of shade on cotton. *American Society of Agronomy* 39: 308-317.
- Knight KMM, Brier BH, Lucy MJ, Kopittke RA.** 2007. Impact of mirid (*Creontiades* spp.) (Hemiptera: Miridae) pest management on *Helicoverpa* spp. (Lepidoptera: Noctuidae) outbreaks: the case for conserving natural enemies. *Pest Management Science* 63: 447-452.
- Kolmes SA.** 1985. An information theory analysis of task specialization among worker honey bees performing hive duties. *Animal Behavior* 33: 181-187.
- Kolmes SA, Winston ML.** 1986. A quantitative method for assessing some aspects of the independent of sampling in behavioural studies of worker honey bees. *Journal of Apicultural Research* 25: 209-212.
- Kono M, Tobe H.** 2007. Is *Cycas revolute* (Cycadaceae) wind- or insect-pollinated? *American Journal of Botany* 94: 847-855.
- Kroyer G, Hegedus N.** 2001. Evaluation of bioactive properties of pollen extracts as functional dietary food supplements. *Innovative Food Science & Emerging Technologies* 2: 171-174.
- Kubik M, Nowacki J, Pidek A, Warakomska Z, Michalczyk L, Goszczyński W, Dwużnik B.** 2000. Residues of captan (contact) and difenoconazole (systemic) fungicides in bee products from an apple orchard. *Apidologie* 31: 531-541.
- Kühnholz S, Seeley T.** 1997. The control of water collection in honey bee colonies. *Behavioral Ecology and Sociobiology* 41: 407-422.
- Kuliev AM.** 1958. The use of honeybees to increase cotton yield. 17<sup>th</sup> International Beekeeping Congress (Summary in Bee World Apicultural Abstracts). Apimondia, Bucharest. 39: 378/58. pp 502-509.

- Landivar JA, Benedict JH.** 1996. Monitoring system for the management of cotton growth and fruiting. Texas Agriculture Experimental Station, Corpus Christi, TX, Bulletin B 02.
- Lavie P.** 1967. Effect of using pollen traps on honey yield from honeybee colonies [Influence de l'utilisation du piège à pollen sur le rendement en miel des colonies d'abeilles] [Summary in English]. *Annals Abeille* 10: 83-95.
- Lavie P, Fresnaye J.** 1963. Experimental study with a pollen trap at the top of the hive [Étude expérimentale de la trappe à pollen en position supérieure]. *Annals Abeille* 6: 277-301.
- Leavitt H, Roberson I.** 2006. Petal herbivory by chrysomelid beetles (*Phyllotrea* sp.) is detrimental to pollination and seed production in *Lepidium papilliferum* (Brassicaceae). *Ecological Entomology* 31: 657-660.
- Levene, H.** 1960. Robust tests for equality of variances. In: Olkin I. (ed.). Contributions to probability and statistics, Stanford University Press, pp 278-292.
- Levin DA, Kerster HW.** 1969. The dependence of bee-mediated pollen dispersal on plant density. *Evolution* 23: 560-71.
- Levin DA, Kerster HW.** 1974. Gene flow in seed plants. In: Dobzhansky T, Hecht MK, Steere WC (eds). Evolutionary Biology. New York: Plenum Press, pp 39-220.
- Lin HC, Phelan PL.** 1991. Identification of food volatiles attractive to dusky sap beetle, *Carpophilus lugubris* (Coleoptera: Nitidulidae). *Journal of Chemical Ecology* 17: 1273-1286.
- Lin HC, Phelan PL, Bartelt RJ.** 1992. Synergism between synthetic food odors and the aggregation pheromone for attracting *Carpophilus lugubris* in the field (Coleoptera: Nitidulidae). *Environmental Entomology* 21: 156-159.
- Lindauer M.** 1953. Division of labour in the honeybee colony. *Bee World* 34: 85-90.
- Lindauer M.** 1955. The water and temperature regulation of the honeybee colony. *Bee World* 36: 62-72.
- Lippok B, Gardine AA, Williamson PS, Renner SS.** 2000. Pollination by flies, bees, and beetles of *Nuphar ozarkana* and *N. advena* (Nymphaeaceae). *American Journal of Botany* 87: 898-902.
- Liven MD.** 1961. Distribution of foragers from honey bee colonies placed in middle of a large field of alfalfa. *Journal of Economic Entomology* 54: 431-433.
- Liven MD, Loper GM.** 1984. Factors affecting pollen trap efficiency. *American Bee Journal* 124: 721-723.
- Llewellyn D, Fitt G.** 1996. Pollen dispersal from two field trials of transgenic cotton in the Namoi Valley, Australia. *Molecular Breeding* 2: 157-166.
- Llewellyn D, Tyson C, Constable G, Duggan B, Beale S, Stell P.** 2007. Contamination of regulated genetically modified cotton in the field. *Agriculture, Ecosystem & Environment* 121: 419-429.
- Loper GM.** 1982. Pollination parameters in modern hybrid cotton. Proceedings of 10<sup>th</sup> Pollination Conference. Carbondale, IL. 29-32.
- Loper GM.** 1986. Cotton pollen: honey bee avoidance and absence of gossypol. *Journal of Economic Entomology* 79: 103-106.
- Loper GM, Berdel RL.** 1980. A nutritional bioassay of honeybee brood-rearing potential. *Apidologie* 11: 181-189.

- Loper GM, Danka RG.** 1991. Pollination tests with Africanized honeybees in southern Mexico. *American Bee Journal* 131: 191-193.
- Loper GM, Davis DD.** 1985. Disparity of cotton pollen dispersal by honey bees visiting upland and Pima pollen parents. *Crop Science* 25: 585-589.
- Loper GM, DeGrandi-Hoffman G.** 1994. Does in hive pollen transfer by honey bees contribute to cross pollination and seed set in hybrid cotton. *Apidologie* 25: 94-102.
- Loper GM, Levin MD, Waller GD.** 1984. Pollen trap efficiency, brood rearing, and trapping precautions. *American Bee Journal* 124: 291.
- Loper GM, Roselle RM.** 1991. Experimental use of BeeScent to influence honey bee visitation and yield of watermelon. *American Bee Journal* 131: 777.
- Lusas EW, Jividen GM.** 1987. Glandless cottonseed: a review of the first twenty-five years of processing and utilization. *Journal of the American Oil Chemists' Society* 64: 839-854.
- Mackenzie KE, Averill AL.** 1992. A new honey bee attractant, the queen mandibular pheromone. *Cranberries* 56: 13-14.
- Mahadevan V, Chandy KC.** 1959. Preliminary studies on the increase in cotton yield due to honeybee pollination. *Madras Agricultural Journal* 46: 23-25.
- Malerbo-Souza DT, Nogueira-Couto RH, Couto LA.** 2004. Honey bee attractants and pollination in sweet orange, *Citrus sinensis* (L.) Osbeck, var. Pera-Rio. *Journal of Venomous Animals and Toxins including Tropical Diseases* 10: 144-153.
- Malone L.** 2004. Potential effects of GM crops on honey bee health. *Bee World* 85: 29-36.
- Mamood AN, Waller GD.** 1990. Recovery of learning responses by honeybees following a sublethal exposure to permethrin. *Physiological Entomology* 15: 55-60.
- Mansfield S, Dillon ML, Whitehouse MEA.** 2006. Are arthropod communities in cotton really disrupted? An assessment of insecticide regimes and evaluation of the beneficial disruption index. *Agriculture, Ecosystems and Environment* 113: 326-335.
- Margalith R, Lensky Y, Rabinowitch HD.** 1984. An evaluation of Beeline as a honey bee attractant to cucumber and its effect on hybrid seed production. *Journal of Apicultural Research* 23: 50-54.
- Martin EC, McGregor SE.** 1973. Changing trends in insect pollination of commercial crops. *Annual Review of Entomology* 18: 207-226.
- Mauney JR.** 1984. Anatomy and morphology of cultivated cottons. In: Kohel RJ, Lewis CF (eds.). Cotton. Agronomy Monograph No 24. American Society of Agronomy, Madison, WI, pp 25-79.
- Mauney JR, Stewart JM.** 1986. Cotton physiology. Cotton Foundation National Cotton Council, Memphis, TN.
- Maurizio A.** 1950. The influence of pollen feeding and brood rearing on the length of life and physiological condition of the honeybee. *Bee World* 31: 9-12.
- Maurizio A.** 1953. Weitere untersuchungen an pollenhörschen. *Beihefte zur Schweizerischen Bienen-Zeitung* 20: 486-556.
- Mayer C, Soka G, Picker M.** 2006. The importance of monkey beetle (Scarabaeidae: Hopliini) pollination for Aizoaceae and Asteraceae in grazed and ungrazed areas



- at Paulshoek, Succulent Karoo, South Africa. *Journal of Insect Conservation* 10: 323-333.
- Mayer DF, Britt RI, Lunden JD.** 1989. Evaluation of BeeScent™ as a honey bee attractant. *American Bee Journal* 129: 41-42.
- Mayer DF, Johansen CA.** 1982. Field evaluation of chemical pollinator attractants on tree fruits. *American Bee Journal* 122: 287-289.
- Mayer DF, Lunden JD.** 1999. Field and laboratory tests of the effects of fipronil on adult female bees of *Apis mellifera*, *Megachile rotundata* and *Nomia melanderi*. *Journal of Apicultural Research* 38: 191-197.
- McDonald JL.** 1968. The behaviour of pollen foragers which lose their loads. *Journal of Apicultural Research* 7: 45-46.
- McGourty MA.** 1992. A field evaluation of "Bee-Here™" pheromone-based forage attractant for honey bees *Apis mellifera* L. applied to red clover, *Trifolium pratense* L. Master of Agriculture Research Paper. Department of Entomology. Oregon State University.
- McGregor ES.** 1959. Cotton-flower visitation and pollen distribution by honeybees. *Science* 129: 97-98.
- McGregor ES.** 1976. Insect pollination of cultivated crop plants. USDA Agriculture Handbook No. 496. pp 171-189.
- McGregor ES, Rhyne C, Worly S Jr, Todd FE.** 1955. The role of honey bees in cotton pollination. *Agronomy Journal* 47: 23-25.
- McGregor ES, Todd FE.** 1956. Cotton is benefited by honey bees. *Prog. Agric. Ariz.* 7: 12.
- McLaren GF, Fraser JA, Grant JE.** 1992. Pollination of apricots. *Orchardist of New Zealand* 65: 22-23.
- McLellan AR.** 1974. Some effects of pollen traps on colonies of honeybee. *Journal of Apicultural Research* 13: 143-148.
- McLellan AR.** 1976. Factors effecting pollen harvesting by the honeybee. *Journal of Applied Ecology* 13: 801-811.
- McLellan AR.** 1977. Honeybee colony weight as an index of honey production and nectar flow: a critical evaluation. *Journal of Applied Ecology* 14: 401-408.
- Meade RM.** 1918. Beekeeping may increase cotton crop. *Journal of Heredity* 9: 282-288.
- Mensah RK.** 2002. Development of an integrated pest management programme for cotton. Part 2: Integration of a lucerne/cotton interplant system, food supplement sprays with biological and synthetic insecticides. *International Journal of Pest Management* 48: 95-105.
- Meyer VG.** 1969. Some effects of genes, cytoplasm, and environment of male sterility of cotton (*Gossypium*). *Crop Science* 9: 237-242.
- Michener, CD.** 1965. A classification of the bees of the Australian and South Pacific regions. *Bulletin of the American Museum of Natural History* 130: 1-362.
- Moeller AR.** 1974. Managing colonies for pollen production. In: Proceedings, 26th International Agricultural Congress, Adelaide. Apimondia Publishing, Bucharest, Romania. 232-239.
- Moeller FE.** 1972. Honey bee collection of corn pollen reduced by feeding pollen in the hive. *American Bee Journal* 112: 210-212.

- Moffett JO.** 1974. Honey bees and other insect visitors to normal and male-sterile cotton. *Dissertation Abstracts International* 35: 2240-2241.
- Moffett JO.** 1983. Hybrid cotton. *In:* Jones CE, Little RJ (eds.). Handbook of experimental pollination biology. Van Nostrand Reinhold, New York. pp 508-514.
- Moffett JO, Cobb HB, Rummel RD.** 1980. Bees of potential value as pollinators in the production of hybrid cottonseed on the High Plains of Texas. *In:* Brown JM (ed.). Proceedings of the Beltwide Cotton Production Research Conferences Dallas, Texas. National Cotton Council of America, Memphis, TN. 268-270.
- Moffett JO, McGregor SE, Stith LS.** 1974. Pollination practices with hybrid cotton production. *In:* Brown JM (ed.). Proceedings of the Beltwide Cotton Production Research Conferences Dallas, Texas. National Cotton Council of America, Memphis, TN. 82.
- Moffett JO, Stith LS.** 1972a. Honeybees as pollinators of hybrid cotton. *Environmental Entomology* 1: 368-370.
- Moffett JO, Stith LS.** 1972b. Pollination by honey bees of male-sterile cotton in cages. *Crop Science* 12: 476-478.
- Moffett JO, Stith LS.** 1972c. Bees losses from parathion decreased as distance from sprayed field increased. *American Bee Journal* 112: 174-175.
- Moffett JO, Stith LS, Burkhardt CC, Shipman CW.** 1975a. Honey bee visits cotton flowers. *Environmental Entomology* 4: 203-206.
- Moffett JO, Stith LS, Burkhardt CC, Shipman CW.** 1975b. Influence of cotton genotypes on floral visits of honey bees. *Crop Science* 15: 782-784.
- Moffett JO, Stith LS, Burkhardt CC, Shipman CW.** 1976a. Insect visitors to cotton flowers. *Arizona Academic Science* 11: 47-48.
- Moffett JO, Stith LS, Burkhardt CC, Shipman CW.** 1976b. Nectar secretion in cotton flowers and its relation to visits by honey bees. *American Bee Journal* 116: 32, 34, 36.
- Moffett JO, Stith LS, Burkhardt CC, Shipman CW.** 1976c. Fluctuation of wild bee and wasp visits to cotton flowers. *Arizona Academic Science* 11: 64-68.
- Moffett JO, Stith LS, Shipman CW.** 1976d. Influence of distance from pollen plant on seed produced by male-sterile cotton. *Crop Science* 16: 765-766.
- Moffett JO, Stith LS, Shipman CW.** 1978a. Producing hybrid cotton seed on a field scale using honey bee as pollinators. *In:* Brown JM (ed.). Proceedings of the Beltwide Cotton Production Research Conferences. National Cotton Council of America, Memphis, TN. pp 77-80.
- Moffett JO, Stith LS, Shipman CW.** 1978b. Effect of honey bee visits on boll set, seed produced, and yield of Pima cotton. *In:* Brown JM (ed.). Proceedings of the Beltwide Cotton Production Research Conferences Dallas, Texas. National Cotton Council of America, Memphis, TN. pp 80-82.
- Moffett JO, Stith LS, Shipman CW.** 1979a. Honey bees and the production of hybrid cotton seed. *American Bee Journal* 119: 492,493,542.
- Moffett JO, Stoner A, Wardecker AL.** 1977a. The wardecker waterer. *American Bee Journal* 117: 364, 365, 378.
- Moffett JO, Stoner A, Wardecker AL.** 1977b. Methods of reducing losses of honey bees caused by spraying cotton with insecticides. *Journal of Economic Entomology* 70: 737-741.

- Moffett JO, Waller GD, Rummel RD.** 1981. 1980 study on insect pollinators and hybrid cotton production in the High Plains of Texas. *In:* Brown JM (ed.). Proceedings of the Beltwide Cotton Production Research Conferences Dallas, Texas. National Cotton Council of America, Memphis, TN. p 88.
- Moffett JO, Wilson WT, Stoner A, Wardecker A.** 1979b. Effect of fifteen combinations of four management methods on losses of honey bees caused by spraying insecticides on cotton. *Journal of Economic Entomology* 72: 453-455.
- Mohan P, Kairon MS.** 1999. Nectar glands and honey bee pollination in cotton (*Gossypium*). *Advances in Plant Sciences* 12: 625-626.
- Momose K, Nagamitsu T, Inoue T.** 1998. Thrips cross-pollination of *Popowia pisocarpa* (Annonaceae) in a lowland dipterocarp forest in Sarawak. *Biotropica* 30: 444-448.
- Moriya** .1966. Effects of pollen trap on numbers of pollen foragers in honeybee colony. *Japanese Journal of Ecology* 16: 105-109.
- Morse RA, Calderone NW.** 2000. The value of honeybees as pollinators of US crops in 2000. *Bee Culture* 128: 2-15.
- Mound LA.** 1962. Extra-floral nectaries of cotton and their secretion. *Empire Cotton Grower Review* 39: 254-261.
- Mulroony JE.** 1999. Optimization of fipronil application. *In:* Proceedings of the Beltwide Cotton Production Research Conferences Orlando, Florida. National Cotton Council of America, Memphis, TN. pp 1150-1151.
- Murawski DA.** 1987. Floral resource variation, pollinator response and potential pollen flow in *Psiguria warscewiczii*. *Ecology* 68: 1273-1282.
- Nabors RA.** 1997. Trapping pollen collection of honeybee *Apis mellifera* L. to determine pollen flow periods. *American Bee Journal* 137: 215-216.
- Nabors, RA.** 2000. The effects of spring feeding pollen substitutes to colonies of *Apis mellifera*. *American Bee Journal* 140: 322-323.
- Nadel H, Pena JE.** 1994. Identity, behaviour, and efficacy of nitidulid beetles (Coleoptera: Nitidulidae) pollinating commercial *Annona* species in Florida. *Environmental Entomology* 23: 878-886.
- Nagel J, Peña JE, Habeck D.** 1989. Insect pollination of atemoya in Florida. *Florida Entomology* 72: 208-211.
- Naranjo SE.** 2005. Long-term assessment of the effects of transgenic *Bt* cotton on the abundance of nontarget arthropod natural enemies. *Environmental Entomology* 34: 1193-1210.
- Naumann K, Winston ML, Slessor KN, Smirle MJ.** 1994. Synthetic honey bee (Hymenoptera) queen mandibular gland pheromone applications affect pear and sweet cherry pollination. *Journal of Economic Entomology* 87: 1595-1599.
- Neira MC, Lobos NS, Riveros MG, Carrillo RL, Pessot RZ, Mundaca NB.** 1997. Insect fauna associated with flowers of raspberries (*Rubus idaeus* L., cv Meeker) and evaluation of pollination activity of *Apis mellifera* L. under the influence of a pheromonal attractant. *Revista Chilena de Entomologia* 24: 37-44.
- Niles GA, Feaster CV.** 1984. Breeding. *In:* Kohel RJ, Lewis CF (eds.). Cotton. American Society of Agronomy, Madison, WI. pp 201-231.
- Nunez LA, Bernal R, Knudsen JT.** 2005. Diurnal palm pollination by mystropine beetles: is it weather-related? *Plant Systematics and Evolution* 254: 149-171.

- Okumura GT, Savage IE.** 1974. Nitidulid beetles most commonly found attacking dried fruits in California. *National Pest Control Operator News* 34: 4-7.
- Oldershaw D.** 1970. The pollination of highbush blueberries. *Report of Pollination Conference University of Arkansas, 9th MP* 127: 171-76.
- Olsen LG, Hoopingarner R, Martin EC.** 1979. Pollen preference of honeybees sited on four cultivated crops. *Journal of Apicultural Research* 18: 196-200.
- Oosterhuis DM , Jernstedt J.** 1999. Morphology and anatomy of the cotton plant. *In:* Smith CW, Cothren TJ (eds.) Cotton: origin, history, technology, and production. Wiley New York, NY. pp 175-206.
- Oosterhuis DM.** 1990. Growth and development of the cotton plant. *In:* Miley WN, Oosterhuis DM (eds.). Nitrogen nutrition in cotton: Practical Issue, Proceedings, Southern Branch Workshop for Practicing Agronomist. American Society of Agronomy, Madison, WI. 1-24.
- Oosterhuis DM, Wullschleger MJ.** 1988. Cotton main-stem leaves in relation to vegetative development and yield. *In:* Proceedings Beltwide Cotton Physiology Research Conference, New Orleans. pp 82-84.
- Palmer-Jones T.** 1947. The use of pollen supplements in New Zealand. *New Zealand Journal of Agriculture* 75: 147-150.
- Palmer-Jones T, Clinch PG, Briscoe DA.** 1976. Effect of honey bee saturation on the pollination of Chinese gooseberries variety 'Hayward'. *New Zealand Journal of Experimental Agriculture* 4: 255-256.
- Pankiw T.** 2004. Brood pheromone regulates foraging activity of honey bees (Hymenoptera: Apidae). *Journal of Economic Entomology* 97: 748-751.
- Pankiw T, Page RE Jr, Fondrk MK.** 1998. Brood pheromone stimulates pollen foraging in honey bees (*Apis mellifera*). *Behavioral Ecology and Sociobiology* 44: 193-198.
- Parks HB.** 1921. The cotton plant as a source of nectar. *American Bee Journal* 10: 391-393.
- Paton DC.** 1996. Overview in the Australian environment: does *Apis mellifera* disrupt or benefit the native biota? *BioScience* 43: 95-103.
- Pearson, K.** 1896. Mathematical contributions to the mathematical theory of evolution. III. Regression, Heredity, and Panmixia. *Philosophical Transactions of the Royal Society of London* 187: 253-318.
- Pedersen MW, Todd FE, Lieberman FV.** 1950. A portable field cage. *USDA, Bureau of Entomology ET-289.*
- Percival AE, Wendel JF, Stewart JM.** 1999. Taxonomy and germplasm resources. *In:* Smith CW, Cothren TJ (eds.). Cotton; origin, history, technology, and production. Wiley New York, NY. pp 33-63.
- Percival M.** 1947. Pollen collection by *Apis mellifera*. *New Phytologist* 46: 164-171.
- Percival M.** 1955. The presentation of pollen in certain angiosperms and its collection by *Apis mellifera*. *New Phytologist* 45: 353-368.
- Perlak FJ, Oppenhuizen M, Gustafson K, Voth R, Sivasuperamaniam S, Heering D, Carey B, Ihrig RA, Roberts JK.** 2001. Development and commercial use of Bollgard cotton in the USA- early promises versus today's reality. *The Plant Journal* 27: 489-501.

- Pernal SF, Currie RW.** 2001. The influence of pollen quality on foraging behavior in honeybees (*Apis mellifera* L.). *Behavioral Ecology and Sociobiology* 51: 53-68.
- Peter CI, Johnson SD.** 2006. Anther cap retention prevents self-pollination by elaterid beetles in the South African orchid *Eulophia foliosa*. *Annals of Botany* 97: 345-355.
- Petroski RJ, Bartelt RJ, Vetter RS.** 1994. Male-produced aggregation pheromone of *Carpophilus obsoletus* (Coleoptera: Nitidulidae). *Journal of Chemical Ecology* 20: 1483-1493.
- Pham-delégue MH, Jouanin L, Sandoz JC.** 2002. Direct and indirect effects of genetically modified plants on the honey bee. *In*: Devillers J, Pham-delégue MH (eds.). Honeybees: estimating the environmental impacts of chemicals. Taylor & Francis, London. 313-326.
- Phelan PL, Lin H.** 1991. Chemical characterization of fruit and fungal volatiles attractive to dried fruit beetle, *Carpophilus hemipterus* (L.) (Coleoptera: Nitidulidae). *Journal of Chemical Ecology* 17: 1253-72
- Phillips SA Jr., Simpson JL.** 1989. Hybrid cotton pollination in relation to accumulated degree days. *Agronomy Journal* 81: 975-980.
- Picker MD, Midgley JJ.** 1996. Pollination by monkey beetles (Coleoptera: Scarabaeidae: Hopliini): flower and colour preference. *African Entomology* 4: 7-14.
- Prance GT, Arias JR.** 1975. A study of the floral biology of *Victiria amazonica* (Piepp.) Sowerby (Nymphaeaceae). *Acta Amazonica* 5: 109-139.
- Purdie JD, Doull KM.** 1964. Supplementary protein feeding of honeybees on a pollen-deficient honey flow. *The Australian Beekeeper* 66: 76-80.
- Puskadija Z, Stefanic E, Mijic A, Zdunic Z, Paradzikovic N, Florijancic T, Opacak A.** 2007. Influence of weather conditions on honey bee visits (*Apis mellifera carnica*) during sunflower (*Helianthus annuus* L.) blooming period. *Agriculture Scientific and Professional Review* 13: 230-233.
- Pyke BA, Brown EH.** 1996. The cotton pest and beneficial guide. CRDC, Narrabri and CTPM, Brisbane. pp. 51.
- Qaim M.** 2003. Bt cotton in India: field trial results and economic projections. *World Development* 31: 165-174.
- Radoev L, Bozhirov.** 1961. Studies on bee pollination and honey productivity of cotton. *Proceedings 19<sup>th</sup> International Congress of Apiculture, Liblice, Czechoslovakia.* 99.
- Rajotte EG, Fell RD.** 1982. A commercial bee attractant inactive in enhancing apple pollination. *Hortscience* 17: 230-231.
- Rapp R.** 1981. The effect of pollination by honeybees (*Apis mellifera* L.) on cucumber cv Delila seed production. Msc Thesis, Hebrew University of Jerusalem.
- Rashad S, Parker RL.** 1958. Major pollen sources in the Manhattan Kansas area and the influences of weather factor upon pollen collection by honeybees. *Proceedings 10<sup>th</sup> International Congress of Entomology* 10: 1037-1046.
- Reddy CS, Aluri R JS, Veerabhadraiah G.** 2002. Floral ecology and beetle pollination in the monoecious *Chrozophora rottleri* (Euphorbiaceae). *Journal of Palynology* 34: 151-156.
- Reid M.** 1973. Use of pollen supplements for feeding bees. *The New Zealand Beekeeper* 35: 43.

- Rhodes J** .2002. Cotton pollination by honey bees. *Australian Journal of Experimental Agriculture* 42 (4): 513-518.
- Ribbands CR**. 1951. The flight range of honeybees. *Journal of Animal Ecology* 20: 302-310.
- Richards JS, Stanley JN, Gregg PC**. 2005. Viability of cotton and canola pollen on the proboscis of *Helicoverpa armigera*: implications for spread of transgenes and pollination ecology. *Ecological Entomology* 30: 327-333.
- Richards KW**. 1993. Non-Apis bees as crop pollinators. *Review Suisse Zoology* 100: 807-22.
- Ridge RL, Turnipseed SG, Sullivan MJ**. 2000. Field comparison of genetically modified cotton containing one strain (Bollgard®) and two strains (Bollgard® II) of *Bacillus thuringiensis kurstaki*. In: Dugger CP, Richter DA (eds). Proceedings of the Beltwide Cotton Conference Volume 2 Memphis, TN: National Cotton Council of America. 1057-1058.
- Robertson IC, Maguire DK**. 2005. Crab spiders deter insect visitations to slickspot pepperglass flowers. *Oikos* 109: 577-582.
- Robertson LN, Rhodes JW**. 1992. Honey bee (*Apis mellifera* L.) deaths near sprayed cotton and observations on bee foraging behaviour in flowering cotton (Hymenoptera: Apidae). *Journal of the Australian Entomological Society* 31: 243-246.
- Robinson WS, Nowogrodzki R, Morse AM**. 1989. The value of honey bees as pollinators of U.S. crops. Part 1. *American Bee Journal* 129: 485-487.
- Rogers REL** . 2004. Why is France banning certain pesticides? *Bee World* 85: 40-41.
- Room PM**. 1979. Insects and spiders of Australian cotton fields. NSW DPI. pp, 63-64.
- Roper, M**. 2002. Fipronil, résumé du dossier toxicologique. Bayer CropScience: 1-85.
- Rotjan R, Calderone N, Seeley T**. 2002. How a honey bee colony mastered additional labor for the task of pollen foraging. *Apidologie* 33: 367-373.
- Roubik DW, Moreno JE, Vergara C, Wittmann D**. 1986. Sporadic food competition with African bee: projected impact on neotropical social bees. *Journal of Tropical Ecology* 2: 97-111.
- Ruther J, Thiemann K**. 1997. Response of the pollen beetle *Meligethes aeneus* to volatiles emitted by intact plants and conspecifics. *Entomologia Experimentalis et Applicata* 84: 183-188.
- Rybakov MN**. 1961. Pollen traps and the activity of bees [In Russian] *Pchelovodstvo* 38: 15-16 (*From Apicultural Abstracts* 429/64, 1964)
- Saffari A, Kevan PG, Atkinson J**. 2004. A promising pollen substitute for honey bees. *American Bee Journal* 144: 230-231.
- Sakai S**. 2001. Thrips pollination of androdioecious *Castilla elastica* (Moraceae) in a seasonal tropical forest. *American Journal of Botany* 88: 1527-1534.
- Sakai S, Inoue T**. 1999. A new pollination system: dung beetle pollination discovered in *Orchidantha inouei* (Labiaceae, Zingiberales) in Sarawak, Malaysia. *American Journal of Botany* 86: 56-61.
- Sakai S, Momose K, Yuuoto M, Inoue T**. 1999. Beetle pollination of *Shorea parvifolia* (section *Mutica*, Dipterocarpaceae) in a general flowering period in Sarawak, Malaysia. *American Journal of Botany* 86: 62-69.

- Salman AG, Abd-El-Raof TK.** 1983. Effect of certain pesticides used against cotton pests on three predaceous insects and honey bee workers. Summary (En). *Bulletin of the Entomological Society of Egypt* 11: 155-162.
- Sawan ZM, Hanna LI, Gad EL Karim GH A, McCuisition WL.** 2002. Relationships between climatic factors and flower and boll production in Egyptian cotton. *Journal of Arid Environments* 52: 499-516.
- Schemske DW, Horvitz CC.** 1984. Variation among floral visitors in pollination ability: a precondition for mutualism specialization. *Science* 225: 519-521.
- Schultheis JR, Ambrose JL, Bambara SB, Managum WA.** 1994. Selective bee attractants did not improve cucumber and watermelon yield. *HortScience* 29: 255-158.
- Scot TD, Winston ML.** 1984. The value of honey bee pollination to Canadian apiculture. *Canadian Beekeeping* 11: 134.
- Sedgley M.** 1982 Anatomy of the unpollinated and pollinated watermelon stigma. *Journal of Cell Science* 54: 341-355.
- Seeley TD.** 1995. The wisdom of the hive. Harvard University Press, Cambridge, MA.
- Sharma HC, Pampapathy G.** 2006. Influence of transgenic cotton on the relative abundance and damage by target and non-target insect pests under different protection regimes in India. *Crop Protection* 25: 800-813.
- Sheesley B, Poduska B.** 1968. Supplemental feeding of honey bee: colony strength and pollination results. *American Bee Journal* 108: 357-359.
- Shshikin EA.** 1952: Moskva Gosudarstvennoe Izdatel'stvo Sel' skokhoz. [In Russian]: 95- 103. (English summary: Effect of pollination by honeybees in increasing the productivity of cotton. *Bee World Apicultural Abstracts* 36: 44/55.)
- Shivanna KR, Cresti M, Ciampolini F.** 1997. Pollen development and pollen pistil interaction. In: Shivanna KR, Sawhney VK (eds.). Pollen biotechnology for crop production and improvements. University of Cambridge Press, pp 15-39.
- Shivanna KR, Linskens HE, Cresti M.** 1991. Pollen viability and pollen vigor. *Theoretical Applied Genetics* 81: 38 42.
- Shoreit MN, Hussein MH.** 1993. Field tests with some protein supplements for feeding bees at Assiut Governorate. *Egyptian Journal of Applied Science* 8: 366-375 [Abstract 1321/98 Apicultural Abstracts 1998] 49: 367
- Sidhu AS, Singh S.** 1961. Studies on agents of cross pollinating of cotton. *Indian Cotton Growing Review* 15: 341-353.
- Sidhu AS, Singh S.** 1962. Role of honey bees in cotton production. *Indian Cotton Growing Review* 16: 18-23.
- Singer RB, Cocucci AA.** 1997. Pollination of *Pteroglossaspis ruwenzoriensis* (Rendle) Rolfe (Orchidaceae) by beetles in Argentina. *Botanica Acta* 110: 338-342.
- Singh PB, Sinha SN.** 1997. Effect of Bee-Q on honey bee visit and the seed yield of the hybrid sunflower. *Seed Research* 24: 151-153.
- Slatkin M.** 1985. Gene flow in natural populations. *Annual Review of Ecology and Systematics* 16: 393-430.
- Slessor KN, Kaminski LA, King GGS, Borden JH, Winston ML.** 1988. .Semiochemical of basis of the retinue response of honey bees. *Nature* 332: 354-356.

- Slessor KN, Kaminski LA, Winston ML.** 1990. Semiochemicals of the honey bee queen mandibular glands. *Journal of Chemical Ecology* 15: 851-860.
- Smith CW, Cothren TJ.** 1999. Cotton; origin, history, technology, and production. Wiley, New York, NY.
- Snelgar WP, Hopkrik G.** 1988. Effect of overhead shading on yield and fruit quality of kiwifruit (*Actinidia deliciosa*). *Journal of Horticultural Science* 63: 731-742.
- Snow AA, Roubik DW.** 1987. Pollen deposition and removal by bees visiting two species in Panama. *Biotropica* 19: 57-63.
- SPSS.** 2007. SPSS. v14, SPSS Inc., Chicago, IL 60611.
- Srinivasan K, Santhanan V, Rajasekara S.** 1972. Development of hybrid cotton utilizing male-sterile line. *Cotton Development* 2: 27-39.
- Stace PS.** 1994. Pollen quality: yellow vine or cat's head (*Tribulus terrestris*) and cotton (*Gossypium hirsutum*). *Bee Briefs* 10: 6-7.
- Standifer LN, Owens CD, Hydak MH, Millsn JP, Levin MD.** 1973. Supplementary feeding of honeybee colonies in Arizona. *Journal of Apicultural Research* 12: 298-301.
- Standifer LN, Waller GD, Hydak MH, Millsn JP, Levin MD.** 1971. Simulative feeding of honeybee colonies in Arizona. *Journal of Apicultural Research* 10: 27-34.
- Steiner KE.** 1998a. Beetle pollination of peacock moraeas (Iridaceae) in South Africa. *Plant Systematics and Evolution* 209: 47-655
- Steiner KE.** 1998b. The evolution of beetle pollination in South Africa orchid. *American Journal of Botany* 85: 1180-1193.
- Steiner KE.** 1994 . Adaptive radiation for pollination in a South African orchid genus. *American Journal of Botany* 81: 189.
- Stephanie B, Dolan C, Tallontire A.** 2003. A gendered value chain approach to codes of conduct in African horticulture. *World Development* 31: 1511-1526.
- Stevens MM, Helliwell S, Warren GN.** 1998. Fipronil seed treatments for the control of chironomid larvae (Diptera: Chironomidae) in aerially-sown rice crops. *Field Crop Research* 57: 195-207.
- Stevenson D, Norstog K, Fawcett P.** 1998. Pollination biology of cycads. In: Owens SJ, Rudall PJ (eds.). Reproductive biology. Royal Botanic Gardens, Kew, UK. pp 277-294.
- Stevenson JH.** 1968. Laboratory studies on the acute contact and oral toxicities of insecticides to honeybees. *Annual of Applied Biology* 61: 467-472.
- Stevenson MA, Benard H, Bolger P, Morris RS.** 2005. Spatial epidemiology of the Asian honey bee mite (*Varroa destructor*) in the North Island of New Zealand. *Preventive Veterinary Medicine* 71: 241-252.
- Stith LS.** 1970. A bee in hybrid cotton production. *Rep. Pollination Conf. Univ. Ark., 9th MP* 127: 28-32.
- Stoner A, Moffett JO, Wilson WT, Standifer LN.** 1981. *Apis mellifera*: effect of management of one- and two-queen colonies on bee losses by spraying insecticides on cotton. *Journal of the Georgia Entomological Society* 16: 323-351.
- Synge AD.** 1947. Pollen collection by honey bees (*Apis mellifera*). *Journal of Animal Ecology* 16: 122-138.



- Szabo TI.** 1980. Effect of weather factors on honeybee flight activity and colony weight gain. *Journal of Apicultural Research* 19:164-171.
- Taber S.** 1971. Influence of pollen location in the hive on its utilization by the honey bee colony. *Journal of Apicultural Research* 12: 17-20.
- Tanda AS.** 1983. Assessing the role of honey bees in a field of Asiatic cotton (*Gossypium arboreum* L.). *American Bee Journal* 123: 593-594.
- Tanda AS.** 1984. Bee pollination increase yield of 2 interplanted varieties of Asiatic cotton (*Gossypium arboreum* L.). *American Bee Journal* 124: 539-540.
- Tanda AS, Goyal NP.** 1979a. Preliminary observation on the effect of intervarietal bee pollination of desi cotton (*Gossypium arboreum* Linn.). *Indian Journal of Entomology* 41: 281-282.
- Tanda AS, Goyal NP.** 1979b. Insect pollination in Asiatic cotton (*G. arboreum*). *Journal of Apicultural Research* 18: 64-72.
- Tanda AS, Goyal NP.** 1979c. Pollen dispersal by insects in desi cotton (*G. arboreum* L.). *Seed & Farms* 5: 56-59.
- Ter-Avanesian D.** 1978a. Significance of pollen amount for fertilization. *Bulletin of the Torrey Botanical Club* 105: 2-8.
- Ter-Avanesian D.** 1978b. The effect of varying numbers of pollen grains used in fertilization. *Theoretical and Applied Genetics* 52: 77-79.
- Thompson HM.** 2003. Behavioural effects of pesticides in bees: their potential for use in risk assessment. *Ecotoxicology* 12: 317-330.
- Thorp RW.** 1979. Honeybee foraging behavior in California almond orchards. In: Caron DM (ed.). Proceedings of Fourth International Symposium on Pollination. Maryland Agric. Exp. Sta. Special Misc. Publ. No. 1: 148-152.
- Thorp RW.** 2000. The collection of pollen by honeybees. *Plant Systematics and Evolution* 222: 211-223.
- Tingle CC, Rother JA, Dewhurst CF, Lauer S, King WJ.** 2003. Fipronil: environmental fate, ecotoxicology, and human health concerns. *Review of Environmental Contamination and Toxicology* 176: 1-66.
- Todd EF, McGregor SE.** 1960. The use of honey bees in the production of crops. *Annual Review of Entomology* 5: 265-278.
- Todd FE, Bishop RK.** 1940. Trapping honeybee gathered pollen and affecting yield. *Journal of Economic Entomology* 33: 866-870.
- Todd FE, Reed CB.** 1970. Brood measurement as a valid index to the value of honey bees as pollinators. *Journal of Economic Entomology* 63: 148-149.
- Tsirakoglou V, Thrasylvoulou A, Hatjina F.** 1997. Techniques to increase the attractiveness of kiwi flowers to honey bees. *Acta Horticulturae* 444: 439-445.
- Umbeck PF, Barton KA, Nordheim EV, McCarty JC, Parrot WL, Jenkins JN.** 1991. Degree of pollen dispersal by insects from a field test of genetically engineered cotton. *Journal of Economic Entomology* 84: 1943-1950.
- Vaissiere BE.** 1991a. Honey bee stocking rate, pollinator visitation, and pollination effectiveness in upland cotton grown for hybrid seed production. *The Sixth International Symposium on Pollination; Ruijter, A. de. International Society for Horticultural Science (ISHS). Wageningen (Netherlands), pp 359-363.*

- Vaissiere BE.** 1991b. Honey bees *Apis mellifera* L. (Hymenoptera: Apidae), as pollinators of upland cotton. *G. hirsutum* L. (Malvaceae) for hybrid seed production. PhD Dissertation, Texas A&M University.
- Vaissiere BE, Loper GM, Rummel DR.** 1982. Pollen transfer in hybrid cotton on the high plains of Texas. *In: Brown JM (ed.). Proceedings of the Beltwide Cotton Production Research Conferences.* National Cotton Council of America, Memphis, TN, 91-92.
- Vaissiere BE, Moffett JO, Loper GM.** 1984. Honey bees as pollinators of hybrid cotton seed production on the Texas high plains. *Agronomy Journal* 76: 1005-1010.
- Vaissiere BE, Vinson SB.** 1994. Pollen morphology and its effect on pollen collection by honey bee, *Apis mellifera* L., with special reference to upland cotton, *G. hirsutum* L. *Grana* 33: 128-138.
- Van Deynze AE, Sundstrom FJ, Bradford.** 2005. Pollen mediated gene flow in California cotton depends on pollinator activity. *Crop Science* 45: 1565-1570.
- Van Driesche RG, Bellows TS.** 1996. Biological Control. New York: Chapman & Hall.
- Van Kleunen M, Nänni I, Donaldson JS, Manning JC.** 2007. The role of beetle marks and flower colour on visitation by monkey beetles (Hoplitiini) in the greater Cape floral region, South Africa. *Annals of Botany* 100: 1483-9.
- Vansell GH.** 1944a. Cotton nectar and relation to bee activity and honey production. *Journal of Economic Entomology* 37: 528-530.
- Vansell GH.** 1944b. Some western nectars and their corresponding honeys. *Journal of Economic Entomology* 37: 530-533.
- Vaughan DM, Calderone NW.** 2002. Assessment of pollen stores by foragers in colonies of the honey bee, *Apis mellifera* L. *Insectes Sociaux* 49: 23-27.
- Villeneuve J.** 1988. Pollen trapping versus honey production. *American Bee Journal* 6: 612-613, 641.
- Wade MR, Zalucki MP, Wratten SD, Robinson KA.** 2008. Conservation biological control of arthropods using artificial food sprays: Current status and future challenges *Biological Control* 45:185-199.
- Wafa AK, Ali AM, Bishara RH.** 1968a. Contamination of pollen grains of cotton plants with certain insecticides. *Bulletin of the Entomological Society of Egypt, Economic Series* 2: 227-321.
- Wafa AK, Ali AM, Bishara RH.** 1968b. Contamination of nectar with insecticides in cotton fields. *Bulletin of the Entomological Society of Egypt, Economic Series* 2: 241-245.
- Wafa AK, Ibrahim SH.** 1957. Temperature as factor affecting pollen gathering activity by the honeybee in Egypt. *Bulletin of Faculty of Agriculture Cairo University.* No. 163.3
- Wafa AK, Ibrahim SH.** 1959. Pollinators of chief sources of nectar and pollen grain plants in Egypt. *Bulletin of the Entomological Society of Egypt* 43: 133-154.
- Wafa AK, Ibrahim SH.** 1960a. The effect of the honeybee as a pollinating agent on the yield of broad bean. *Bulletin of Faculty of Agriculture Cairo University.* No. 205
- Wafa AK, Ibrahim SH.** 1960b. The effect of the honeybee as a pollinating agent on the yield of clover and cotton. *Bulletin of Faculty of Agriculture Cairo University.* No. 206

- Waller GD.** 1970. Attracting honey bees to alfalfa with citral, geraniol, and anise. *Journal of Apicultural Research* 9: 9-12.
- Waller GD.** 1972. Evaluating responses of honey bees to sugar solutions using an artificial flower feeder. *Annals of the Entomological Society of America* 65: 857-861.
- Waller GD.** 1980. A modification of the O.A.C. pollen trap. *American Bee Journal* 120:119-121.
- Waller GD.** 1982. Hybrid cotton pollination. *American Bee Journal* 122: 555-560.
- Waller GD, Caron DM, Loper GM.** 1981a. Pollen patties maintain brood rearing when pollen is trapped from the honey bee colonies. *American Bee Journal* 121: 2, 101-103, 105.
- Waller GD, Estes BJ, Buck NA, Taylor KS, Crowder LA.** 1988. Residual life and toxicity to honey bees (Hymenoptera: Apidae) of selected pyrethroid formulations applied to cotton in Arizona. *Journal of Economic Entomology* 81: 1022-1026.
- Waller GD, Mamood AN.** 1991. Upland and Pima cotton as a pollen donor for male-sterile upland seed parent. *Crop Science* 31: 265-266.
- Waller GD, Moffett JO.** 1981. Pollination of hybrid cotton on the Texas High Plains: nectar production and honey bee visits. *In: Brown JM (ed.). Proceedings of the Beltwide Cotton Production Research Conferences. National Cotton Council of America, Memphis, TN, pp 85-87.*
- Waller GD, Moffett JO, Loper GM, Martin JH.** 1985a. An evaluation of honey bee foraging activity and pollination efficacy for male-sterile cotton. *Crop Science* 25: 211-214.
- Waller GD, Torchio PF, Stith LS.** 1978. A comparison of *Apis mellifera* and *Osmia fulviventris* as pollinators of caged cotton in Arizona. *Proceedings of the Fourth International Symposium on Pollination, Maryland, 299-305.*
- Waller GD, Vaissiere BE, Moffett JO, Martin JH.** 1985b. Comparison of carpenter bees (*Xylocopa varipuncta*) and honey bees (*Apis mellifera* L.) as pollinators of male-sterile cotton in cages. *Journal of Economic Entomology* 78: 558-561.
- Waller GD, Wilson FD, Martin JH.** 1981b. Influence of phenotype, and time-of-day on nectar production in cotton. *Crop Science* 21: 211-214.
- Ward AL.** 2002. Cotton insect management in the Northern Territory: challenges ahead and research to overcome the challenges. *In: Proceedings of the 11<sup>th</sup> Australian Cotton Conference. Australian Cotton Growers Research Association, Brisbane, Queensland, Australia. 111-115.*
- Ward AL.** 2005. Development of a treatment threshold for sucking insects in determinate Bollgard II transgenic cotton grown in winter production areas. *Australian Journal of Entomology* 44: 310-315.
- Weaver JB Jr.** 1978. Observations on bee activity in several genotypes of cotton. *In: Brown JM (ed.). Proceedings of the Beltwide Cotton Production Research Conferences. National Cotton Council of America, Memphis, TN. 76-77.*
- Webster TC, Thorp RW, Briggs D, Skinner J, Parisian T.** 1985. Effect of pollen traps on honeybee foraging and brood rearing during almond and prune pollination. *Environmental Entomology* 14: 683-686.
- Wendel JF, Burbaker CL, Percival E.** 1992. Genetic diversity in *Gossypium hirsutum* and the origin of upland cotton. *American Journal of Botany* 79: 1291-1310.

- Whetton P.** 2001. Climate change for Australia. <http://www.cmar.csiro.au/e-print/open/projections2001.pdf>.
- Whitehouse ME, Wilson LJ, Fitt GP.** 2005. A comparison of arthropod communities in transgenic *Bt* and conventional cotton in Australia. *Environmental Entomology* 34: 1224-1241.
- Whitehouse ME, Wilson LJ, Fitt GP.** 2007. Target and non-target effects on the invertebrate community of Vip cotton, a new insecticidal transgenic. *Australian Journal of Agricultural Research* 58: 273-285.
- Williams MR.** 1996. Cotton insect losses. *In:* Dugger P, Richter D (eds.). Proceedings of the Beltwide Cotton Conferences. National Cotton Council of America, Memphis, TN. 670-89.
- Williams MR.** 2002. Cotton insect losses. *In:* Nashville TN, Hardee DD, Ottens RS, Burris G, Ottea JA (eds.). Proceedings of the Beltwide Cotton Conferences. National Cotton Council of America, Memphis, TN. 1217-1273.
- Wills RT.** 1989. Management of the flora utilised by the European honey bee in Kwongan of the Northern sandplain of Western Australia. PhD Thesis, University of Western Australia, Perth.
- Wilson FD, Stapp BR.** 1984. Crossing success in cotton in Arizona as affected by irrigation, number of flowers pollinated, and time of emasculation. *Agronomy Journal* 76: 457-460.
- Winston ML.** 1987. The biology of the honey bee. *Cambridge. Harvard University Press.*
- Winston ML, Chalmers WT, Lee P.** 1983. Effects of two pollen substitutes on brood mortality and length of adult life in the honeybee. *Journal of Apicultural Research* 22: 49-52.
- Winston ML, Punnett EN.** 1982. Factors determining temporal division of labor in honey bees. *Canadian Journal of Zoology* 60: 2947-2952.
- Winston ML, Slessor KN.** 1993. Applications of queen honey bee mandibular pheromone for beekeeping and crop pollination. *Bee World* 74: 111-127.
- Winston ML, Slessor KN, Rubink WL, Villa JD.** 1993. Enhanced pheromone lures to attract honey bee swarms. *American Bee Journal* 133: 58-60.
- Winston ML, Slessor KN, Williams LG, Naumann HA, Higo MH, Kaminski LA.** 1989. The influence of queen mandibular pheromones on worker attraction to swarm cluster and inhibition of queen rearing in the honey bee (*Apis mellifera* L.). *Insect Sociaux* 36: 15-27.
- Woyke HW.** 1981. Some aspects of the role of the honeybee in onion seed production in Poland. *Acta Horticulturae* 111: 91-98.
- Wratt EC.** 1968. The pollinating activities of bumble bees and honeybees in relation to temperature, competing forage plants, and competition from other foragers. *Journal of Apicultural Research* 7: 61-66.
- Wyatt R.** 1980. The impact of nectar-robbing ants on the pollination system of *Asclepias curassavica*. *Bulletin of the Torrey Botanical Club* 107: 24-28.
- Yasour H, Tsuk G, Robin B.** 2002. Potential benefits and risks associated with the introduction of herbicide-resistant transgenic cotton in Israel. *In:* Spafford Jacob H, Dodd J, Moore JH. (eds.). Papers and Proceedings, 13<sup>th</sup> Australian Weeds Conference. Plant Protection Society of Western Australia Inc., Perth, 634-637.

- Ying GG, Kookana R.** 2002. Laboratory and field studies on the degradation of fipronil in a soil. *Australian Journal of Soil Research* 40: 1095-1102.
- Young HJ.** 1986. Beetle pollination of *Dieffenbachia longispatha* (Araceae). *American Journal of Botany* 73: 931-944.
- Young HJ.** 1988. Differential importance of beetle species pollinating *Dieffenbachia longispatha* (Araceae). *Ecology* 69: 832-844.
- Zerega N, Mound L, Weiblen G.** 2004. Pollination in the new endemic *Antiaropsis decipiens* (Moraceae) is mediated by a new thrips, *Thrips antiaropsidis* sp. nov. (Thysanoptera: Thripidae). *International Journal of Plant Science* 165: 1017-1026.

## Appendix I

### ELISA TESTING PROCEDURE FOR Cry1Ac AND Cry1Ac GENES

The standard procedure was as follows:

- 
- Day1**
- 1- Coat plates with ELISA Coating Buffer (place 200  $\mu$ L, in each well and the dilution of antibody as per tube-concentration varies depending on the strength of the antibody which is extracted from rabbits-Danny). Concentration should be supplied with the antibody. Store antibodies in the refrigerator (4°C).
  - 2- Place covers on ELISA Plates (covers are reused after cleaning) and put in refrigerator (4°C) overnight.
- Day2**
- 1- Wash plates with PBST (Single Strength) twice, rotating the plate after the first wash so as to get a through washing. Use either the Bio-Rad Plate Washer on Protocol 2, or alternatively the large plate washer located at the sink
  - 2- Store ELISA Plate in snap-lock bag at -20°C (able to be indefinitely at -20°C freezer).
- 

#### Assay

---

- Day1**
- Clip the fat end off the seed (approximately 1/3 seed), keep pointy end. Soak on very wet tissue using distilled water in sealed container (2 or 3 damp tissues under and over seed in a plastic take away container with lid) on bench overnight.
- Day2**
- 1- Squeeze seed out of the seed coat and place one seed into each individual tube for grinding.
  - 2- Add approximately 400  $\mu$ L of ELIAS Extraction Buffer using multipipttor and grind (3 mm steel ball bearing in each tube put in by an auto-dispensor). Ensure caps are firmly before placing the sample box on the shaker.
  - 3- Place paper in lid of shaker box to absorb and leaked product. Place Retsch Mixer Mill for 2 minutes and then rotate and repeat for another 2 minutes.
  - 4- After grinding remove caps and check to see that there is sufficient extraction buffer in each tube. If not, add some additional buffer, If any seed is missing from tube/s, mark top of tube with texta and transfer this marking to the plate to eliminate false negatives. Keep tubes containing the extract (seed) in the refrigerator until the Elisa Plates have been run the next day. The extract can be
-

---

used to reconfirm any questionable results on the plates using Lateral Flow Strips. See Verification of Questionable Results at the end of this method.

- 5- Take plates out of the freezer approximately 15 to 30 minutes prior to use. Ensure plates don not dry out and keep lids on them all times.
- 6- Prepare coated plates by adding 180  $\mu$ L [PBST (single strength) containing Sigma Chicken Ovalbumin A 5378@1 mg/mL dilution (store in refrigerator 4°C) and conjugate @ 1/2000 dilution (store in refrigerator -20°C) ].
- 7- Add 20  $\mu$ L of ground sample (using wide bore tips). Draw line down centre of plate and tube box to keep your bearing when adding the sample to each well). Same amount of sample is added to both P1 and P2 plates.
- 8- Cover plates overnight at 4°C in moist, sealed box (plastic box with moistened paper in the bottom so it dose not dry out);

### **Day3**

- 1- Shake out plates.
- 2- Wash plates with PBST (Single Strength) using Bio-Rad Microtech Plate Washer. Program 2 should be sued. Refer to programming of Microtech Plate Washer for parameters for washing. Alternatively use the large plate washer located at the sink.
- 3- Add 150  $\mu$ L to each well of Substrate Buffer containing Sigma 104 Phosphatase Substrate (56 mg/ 100 mL). Store Sigma 104 Phosphatase Substrate in Freezer (-20°C) for up to 1 year. Use multi-pipettor to put Substrate Buffer in each well. Check to see all walls have been dosed on complication.
- 4- Leave covered on bench to develop into a bright yellow color (1 to 2 hours). P2 plates tend to develop slower than P1 plates.

---

### **Proceed**

---

Mixer mill setting: - seed frequency 28/seconds, 2  $\times$  2 minutes.

Verification Of Questionable Positive on Elisa Plates

Methods available to recheck questionable results on Elisa plates:

- 1- Use Microplate Reader – 405 nm.
  - 2- Using original seed extract, dilute in 4 with Elisa Extract Buffer in a separate tube and use the appropriate lateral flow strip for confirmation.
    - i. Place a cottonseed on a piece of weigh paper or waxed paper.
-

- 
- ii. Fold the paper over the cottonseed and crack or smash into small pieces using pliers or other suitable means.
  - iii. Put the cracked cottonseed into a 1.5-mL sample tube and the about 0.75 mL of Trait √ Leaf & Seed Sample buffer to the tube.
  - iv. Let the tube stand for 3-5 minutes while shaking intermittently or stirring with the stirrer.
  - v. Insert the labeled filter cover of the Seed√Btk lateral flow test strip into the sample tube containing the cottonseed sample extract. The arrows on the filter cover should point into the tube. Allow the test strip to remain in the tube in an upright position for 5 minutes.
  - vi. Proceed to Interpreting the Lateral Flow Test Strip.

Reference “Method supplied from CSIRO Plant Industry, Canberra (Dr Danny Llewellyn) June 2003”

---

### **P1 α P2 Elisa Protocol EAP-002 (Feb 2006)**

Seed clipped one end and imbibed over night so they could have the contents squeezed out.

Calculations for P1 α P2 conjugates α ovalbumin

$$\begin{aligned} \text{Dosage per well } 180 \mu\text{L} &= 180 \times 100 \times 5/1000 \\ &= 90 \text{ mL} \rightarrow 100\text{mL} \end{aligned}$$

Chicken ovalbumin A5378, 1mg/mL

$$100 \text{ mL} = 100 \text{ mg or } 0.100 \text{ g in PBST (X1)}$$

Conjugates P1 α P2 (separately) 1/ 2000

$$100 \text{ mL} = 0.050 \text{ mL or } 50 \text{ mL in PBST (X1)}$$

$$\text{P1} = 1.12.03 \quad \text{P2} = 10.12.03$$

Calculations for Sigma 104 (10 plates)

$$\text{Dosage per wall } 150 \mu\text{L} = 150 \times 100 \times 10 / 1000$$

Sigma 104, 56 mg /100mL

$$160 \text{ mL} = 84 \text{ mg or } 0.084\text{g in substrate buffer}$$

$$\text{Dosage of extract per well P1 α P2} = 20 \mu\text{L}$$



**Results of ELISA test show the position, type of detected Bt gene in tested samples.**

<b>Plate</b>	<b>Position</b>	<b>Cry1Ac</b>	<b>Cry2Ab</b>	<b>RVR</b>
1-96	B2	+tive	sl +tive	-tive
	F11	+tive	-tive	sl +tive
101-196	C5	+tive	-tive	-tive
	A7	+tive	sl +tive	+tive
	D7	+tive	sl +tive	sl +tive
201-296	None	-	-	-
301-396	None	-	-	-
401-496	H1	+tive	-tive	sl +tive
	F4	+tive	sl +tive	+tive
	B7	+tive	+tive	+tive
<b>Controls – negative</b>				
1-96	D6	-tive	-tive	-tive
401-496	D6	-tive	-tive	+tive

**Appendix II**  
**INCOMING-BEE TRAP**

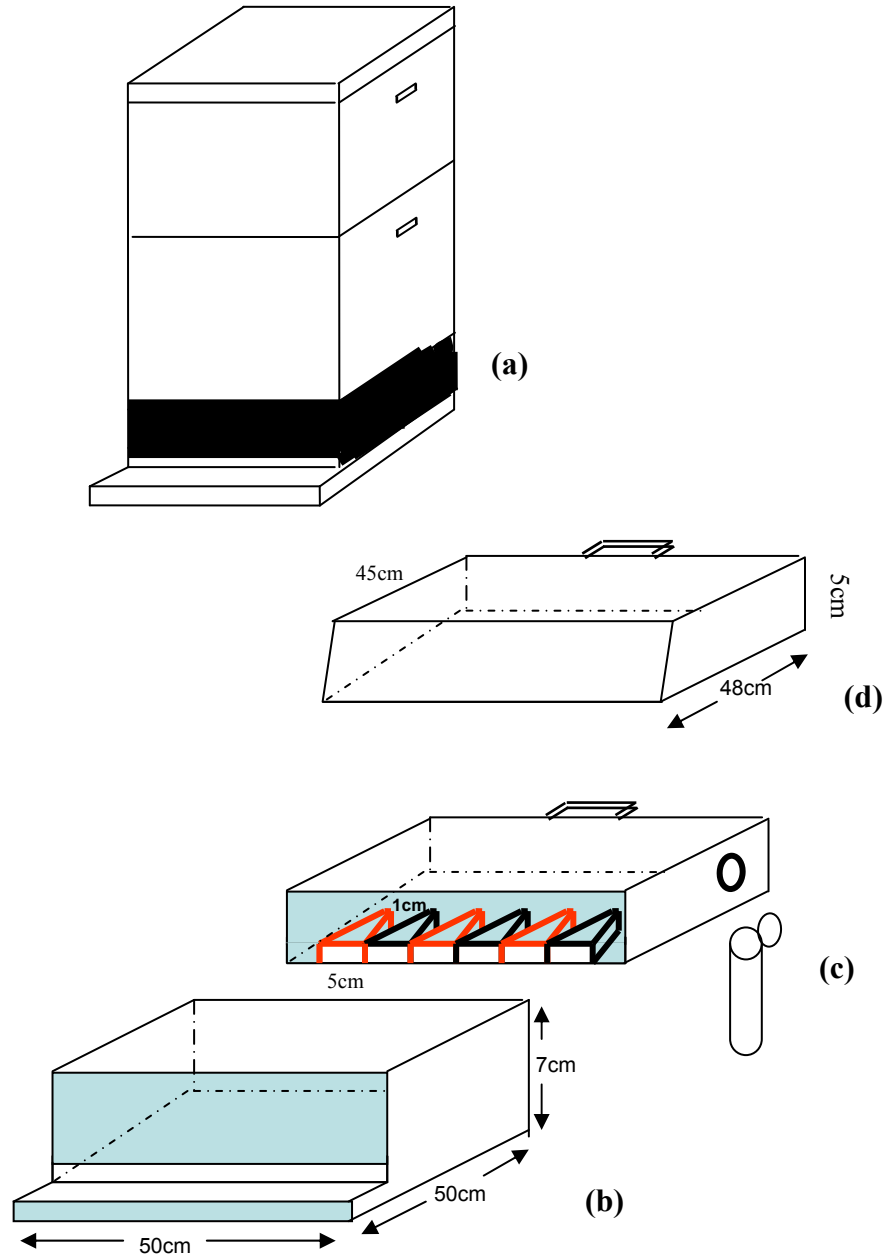

Figure shows the incoming-bee trap for collecting honey bees as they return to the hive (a) trap attached to the hive (b) trap device (c) trapping box (soled) with cone multi-entrances, and back exit to collect the trapped foragers in the container (d) alternative box used when trap is off.