

MATERIALS CHARACTERIZATION BY COMBINED THERMOVOLTAIC DETECTION (TVD) AND THERMAL ANALYSIS (DTA) TECHNIQUES

S.K. SURI AND RAGIAB A. MOKHTAR *

Industrial Research Centre, Tajura–Tripoli (Libya)

(Received 14 March 1990; in final form 30 May 1990)

ABSTRACT

The thermovoltic detection (TVD) technique is based on measurement of the EMF generated by two dissimilar metal electrodes in contact with the specimen. This technique has recently been applied when investigating different types of materials involving thermal decomposition reactions which have more normally been studied by conventional thermal analysis techniques, such as DTA, TG, etc. This paper reports the application of the combined TVD and DTA techniques for thermal characterization of materials. The Harrop DTA system has been modified such that measurements by the two techniques can be made simultaneously in the same environment. Data have been obtained on different types of materials, e.g., $\text{NiSO}_4 \cdot 6\text{H}_2\text{O}$ and $\text{CoSO}_4 \cdot 7\text{H}_2\text{O}$, etc., at a programmed heating rate of $10^\circ\text{C min}^{-1}$. Results obtained by these techniques are discussed and compared with the corresponding values in the literature.

INTRODUCTION

Thermal analysis is an indispensable tool for characterization of materials. It is a family of techniques for measuring some physical parameters of the system in relation to its temperature. Differential thermal analysis (DTA) is one of the most versatile and widely used techniques. Among the recently reviewed [1,2] various electrothermal analysis techniques, thermovoltic detection (TVD) appears to be unique as well as promising. First developed by Wendlandt [3] in 1980, the TVD technique involves measurement of EMF generated by two dissimilar metal electrodes in contact with a specimen which goes through a thermal transition as its temperature is changed. During the thermal decomposition or phase change, an EMF ranging from 0 to ca. 1 V is produced, and is recorded as a function of temperature at a programmed heating rate. Wendlandt and coworkers have applied this technique when studying the thermal decomposition of several

* Author to whom correspondence should be addressed.

types of materials, e.g. metal salt hydrates, polymers and liquids [4–6], amino acids [7], coordination compounds [8], etc. As reported by Wendlandt [4], who applied the TVD technique to study thermal decomposition reactions in $\text{CoSO}_4 \cdot 7\text{H}_2\text{O}$ and $\text{NiSO}_4 \cdot 6\text{H}_2\text{O}$ up to 200°C , TVD peak temperatures were in close agreement with the corresponding DTA peak temperatures in $\text{NiSO}_4 \cdot 6\text{H}_2\text{O}$; however, in the case of $\text{CoSO}_4 \cdot 7\text{H}_2\text{O}$, TVD peaks were observed at much lower temperatures as compared to the corresponding peaks in the DTA curves.

Since several factors can influence the TVD and/or DTA peaks, the aim of the present work is to report setting up of the combined TVD and DTA techniques in a modified Harrop DTA system, such that simultaneous measurements by these techniques can be made on two different samples of the same material (or different materials) in the same thermal environment, and hence results obtained by these techniques can be directly compared. Thermal decomposition reactions in $\text{NiSO}_4 \cdot 6\text{H}_2\text{O}$ and $\text{CoSO}_4 \cdot 7\text{H}_2\text{O}$ have been investigated by applying the TVD and DTA techniques simultaneously, and the results obtained are discussed.

EXPERIMENTAL

A block diagram of the equipment used for the combined TVD/DTA measurements is shown in Fig. 1. A schematic diagram of the sample holder used for TVD measurements is shown in Fig. 2. Reagent grade powder (particle size ≈ 100 mesh), pelletized in the form of a circular disc (approximately 1 cm diameter and approximately 1 mm thickness) under a pressure of ca. 7 tons, was sandwiched between aluminium and platinum foil electrodes, which were covered by mica sheets and were placed between two thin metal plates held together by spring loaded screws passing through another identical metal plate to provide uniform pressure contact between the sample and the electrodes, as illustrated in Fig. 2. A Pt/Rh10–Pt thermocouple kept close to the specimen was used to measure the thermo-EMF, which was fed to the X-channel of a Hewlett–Packard X–Y recorder (model 7047 A) and was later converted into temperature ($^\circ\text{C}$) using

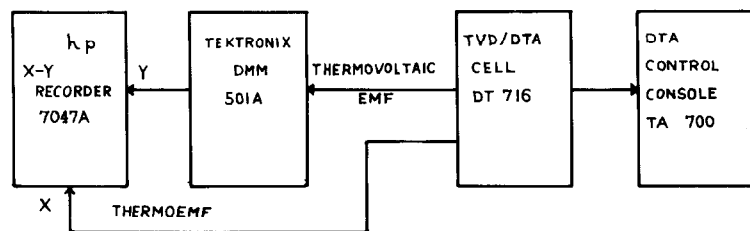

Fig. 1. The equipment for TVD/DTA measurements.

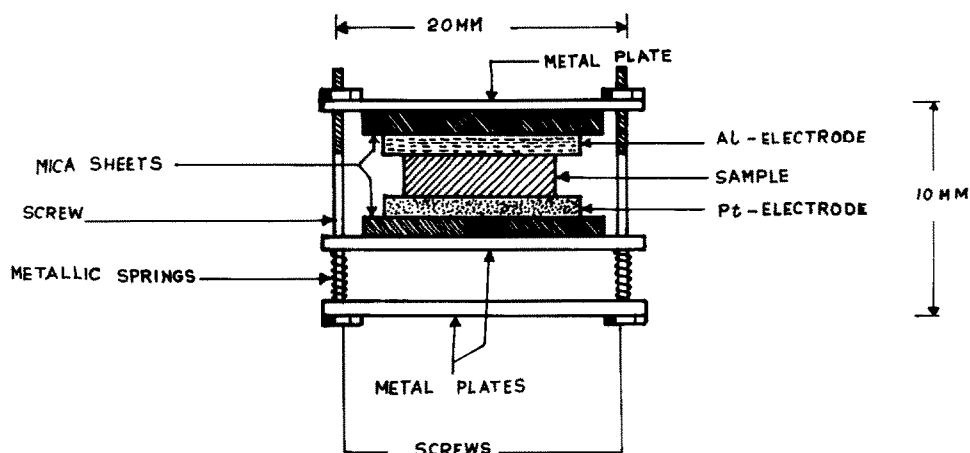

Fig. 2. Schematic of the sample holder.

standard thermo-EMF temperature conversion tables [9]. The thermovoltaic EMF monitored by a Tektronix digital multimeter (model DM501 A) was recorded on the Y-channel of this recorder. For each TVD run, fresh Al electrodes were used; the same Pt electrode was reused after cleaning it.

DTA data were obtained using a Harrop DTA system, which consists of DTA module DT 716 plugged into a TA 700 control console; this includes the temperature controller, programmer and X-Y recorder for plotting the DTA curves. The programmer and the recorder were calibrated following the procedure described earlier [10], and Pt/Rh10-Pt thermocouples were

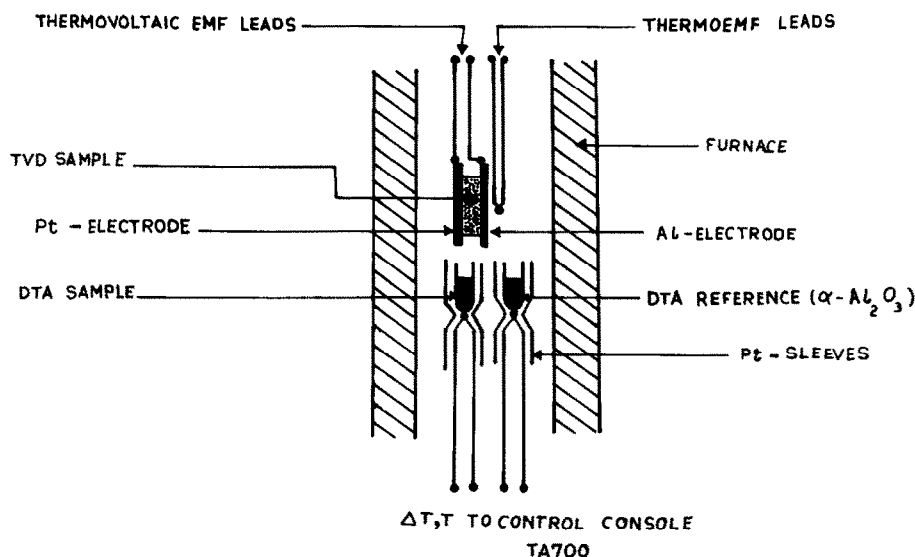

Fig. 3. Schematic of the TVD/DTA cell.

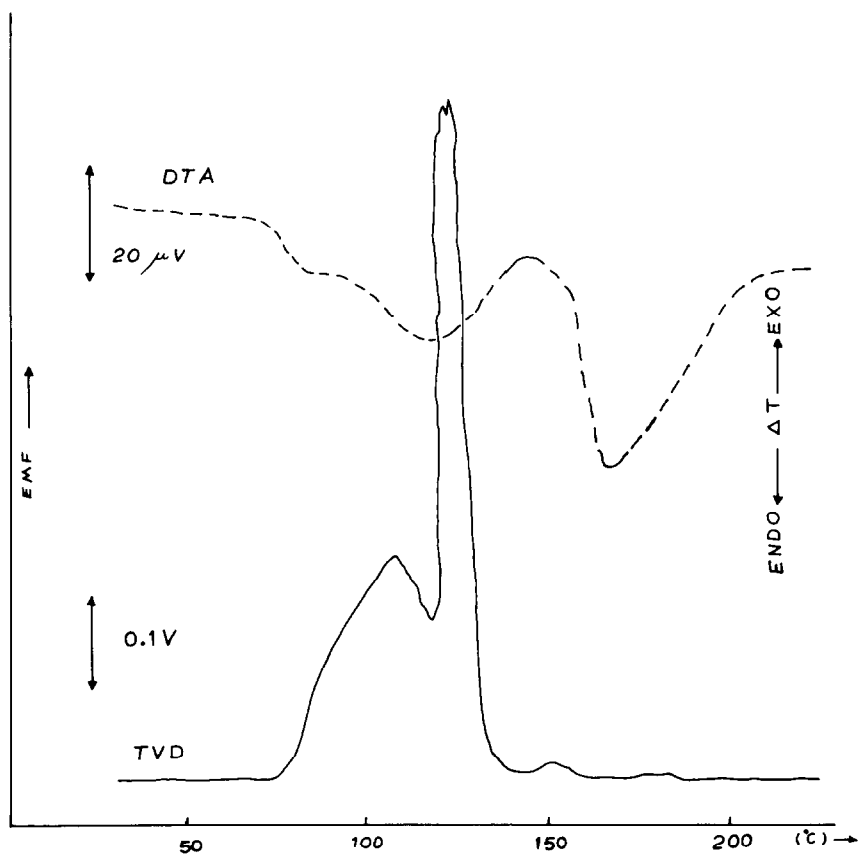

Fig. 4. DTA and TVD curves obtained for $\text{NiSO}_4 \cdot 6\text{H}_2\text{O}$.

used to monitor ΔT and temperature (T). The same powder sample from which pellets were made was used for DTA measurements in which $\alpha\text{-Al}_2\text{O}_3$ was the reference material. The TVD and DTA samples were kept close to each other in the same thermal environment, as illustrated in the schematic diagram of the TVD/DTA cell (Fig. 3). Simultaneous TVD and DTA data were recorded for $\text{NiSO}_4 \cdot 6\text{H}_2\text{O}$ and $\text{CoSO}_4 \cdot 7\text{H}_2\text{O}$ up to ca. 250°C in air at a programmed heating rate of $10^\circ\text{C min}^{-1}$. Several runs were made on these compounds and the data were reproducible.

Typical TVD/DTA curves obtained for $\text{NiSO}_4 \cdot 6\text{H}_2\text{O}$ and $\text{CoSO}_4 \cdot 7\text{H}_2\text{O}$ are shown in Figs. 4 and 5.

RESULTS AND DISCUSSION

As can be seen from the TVD/DTA curves for $\text{NiSO}_4 \cdot 6\text{H}_2\text{O}$ (Fig. 4), thermal decomposition starts around 75°C in both the curves. In the TVD

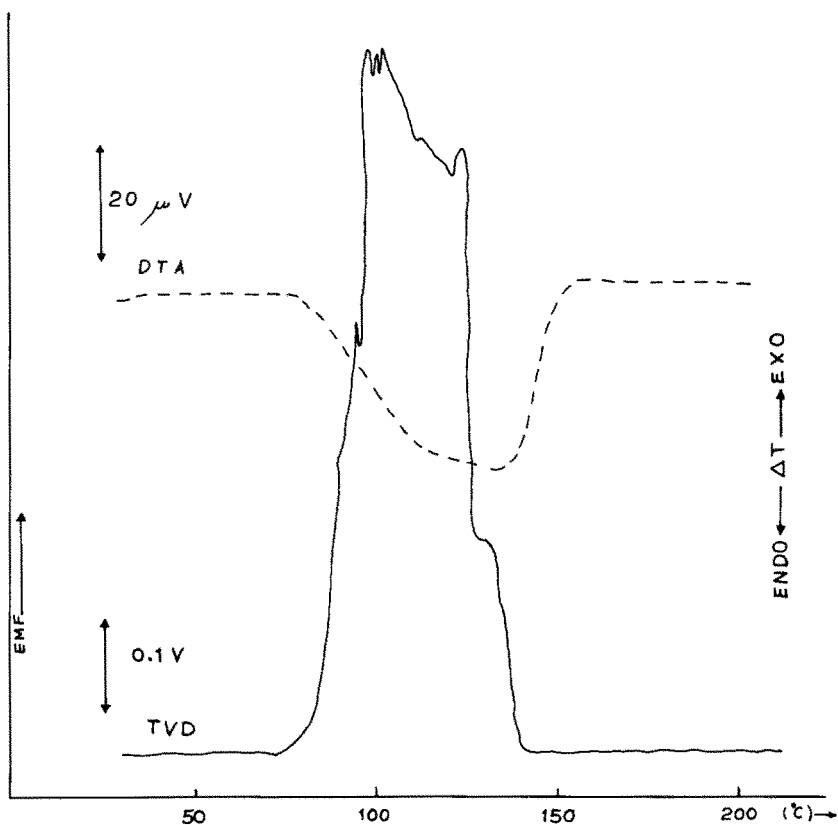
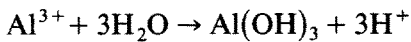
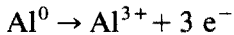

Fig. 5. DTA and TVD curves obtained for $\text{CoSO}_4 \cdot 7\text{H}_2\text{O}$.

curve the first small peak is observed at ca. 108°C , one large peak (maximum peak voltage approximately 0.8 V) is recorded at 122°C and one very small peak can be noted at 152°C . These peak temperatures are in good agreement with the corresponding TVD peak temperatures (several peak maxima between 100 and 125°C and one small peak between 150 and 155°C) obtained by Wendlandt [6]. It is worth noting that, in the DTA curves (Fig. 4), two well resolved peaks at 122 and 165°C and a shoulder peak at ca. 88°C are observed.

Similarly for $\text{CoSO}_4 \cdot 7\text{H}_2\text{O}$, TVD peak temperatures of 100 and 124°C and a maximum peak voltage of ca. 0.75 V , as shown in Fig. 5, agree with the corresponding values of 109 and 122°C and the maximum peak voltage of ca. 0.7 V reported by Wendlandt [4]. However, the presently observed DTA peak temperatures of 115 and 134°C are lower than the corresponding DTA peak temperatures of 136 and 150°C quoted earlier [4]. It may be noted that TVD peak temperatures are close to the corresponding DTA peak temperatures provided that the DTA peaks are small, but TVD peaks are recorded at slightly lower temperatures as compared to the correspond-

ing DTA peaks if the DTA peaks are large; e.g., in $\text{NiSO}_4 \cdot 6\text{H}_2\text{O}$, the TVD peak is at 152°C and the corresponding DTA peak is at 165°C , whereas for $\text{CoSO}_4 \cdot 7\text{H}_2\text{O}$ the TVD peak is at 124°C as compared to the corresponding DTA peak at 134°C . This difference can be easily understood if we realise that the DTA peak temperature does not indicate the true temperature of the test sample [11], which is lower or higher than that of the reference material, because of endothermic or exothermic reactions, by ΔT , whereas the TVD peaks refer to the actual specimen temperature. The thermovoltaic EMF generation is attributed to chemical reaction between the sample and the two dissimilar electrodes. In the present case the probable reaction at the aluminium electrode, which is the active electrode (cathode), is



and at the platinum electrode, which is the positive electrode, the reaction is

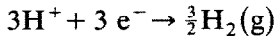

CONCLUSION

In general, like DTA curves, TVD curves are characteristic of the material, and may be used independently or in combination with other thermal analysis techniques for identification of materials. However, the TVD technique is not unique; the TVD curves give thermal analysis information which is not essentially different from that given by DTA curves, although the origin of the thermovoltaic EMF is quite different from that of the DTA data. Since the magnitude of the thermovoltaic EMF ranges between 0 and 1 V, and is much easier to measure directly in comparison with smaller voltage signals which may need amplification in DTA or other thermal analysis techniques, the technique may be quite simple and economical to set up without very sophisticated electronic systems. Further, the TVD technique can be used to study not only thermal decomposition reactions, but also different types of phase change reactions. Further work is needed to widen the scope and utility of this technique as compared with other commonly used thermal techniques.

ACKNOWLEDGEMENTS

The authors are grateful to Dr. A.I. Fadel and Mr. E.M. Zindah for their continuous encouragement during the course of this work.

REFERENCES

- 1 W.W. Wendlandt, *Thermochim. Acta*, 73 (1984) 89.
- 2 W.W. Wendlandt, *Thermochim. Acta*, 72 (1984) 9.
- 3 W.W. Wendlandt, *Thermochim. Acta*, 37 (1980) 121.
- 4 W.W. Wendlandt, in B. Miller (Ed.), *Thermal Analysis*, Vol. 1, Wiley, New York, 1982, p. 320.
- 5 W.W. Wendlandt and S. Contarini, *Thermochim. Acta*, 65 (1983) 321.
- 6 W.W. Wendlandt, *Thermochim. Acta*, 99 (1986) 40.
- 7 S. Contarini and W.W. Wendlandt, *Thermochim. Acta*, 70 (1983) 283.
- 8 C.H. Hsueh and W.W. Wendlandt, *Thermochim. Acta*, 84 (1985) 151.
- 9 *Handbook of Temperature Measurements*, Linseis Co. Selle, F.R.G.
- 10 S.K. Suri, paper presented at the Second Libyan Arab International Conference on Electrical and Electronic Engineering, Tripoli, Libya, March 1989.
- 11 R.W. Grimshaw, *The Chemistry and Physics of Clays*, Benn, London, 1980, p. 254.