

VALIDITY SELECTION FOR BUILDING A PROPOSED MODEL FOR HUMAN RESOURCES INFORMATION SYSTEMS AT THE GENERAL ELECTRICITY COMPANY OF LIBYA USING CONFIRMATORY FACTOR ANALYSIS

Mohamed Maawi. K. Mohamed¹, Nasser Ahmed Habtoor², Mahazan Bin Abdul Mutalib³

Faculty of leadership and Management, Universiti Sains Islam Malaysia
Bandar Baru Nilai, 71800 Nilai, Negeri Sembilan, MALAYSIA.

¹mohmmadmaw@yahoo.com

ABSTRACT

The study aims to set a conceptual framework to measure human resources information systems at the general electricity company in Libya by adopting proper dimensions to measure it through (wages arrangement, personnel data arrangement, fast information restore, monitoring attendance), and to achieve this goal we used confirmatory factor analysis (CFA) by using Amos program. and based on these results, the study found out that this model is the proper and most credible one to measure human resources information systems in industrial organizations in Libya.

Keywords: Wages arrangement, Personnel data arrangement, Fast information restore, Monitoring attendance

INTRODUCTION

General Electricity Company is one of the sectors which focuses on developing its human resources based upon the technological, technical and economic changes. These different changes in investment tools and credit tools and cash and goods exchange technologies make organizations concentrate more on human resources as it is the basis for any success in the organization and in a form to accommodate the fast changing external environment.

Human resources management influences many of the basic tasks and activities which provide human resources according to the current and future needs. So it acquires them and train and develop and push them and organize their relationships with other divisions and many outside bodies (Elmohmed 2007). That may required the development of information systems to manage human resources providing technical support and sufficient expertise to upgrade efficiency and effectiveness of human resources management in providing best service with lowest cost and shortest time. The information systems services have entered advanced fields of human resources management such as recruitment and selection management, personnel performance evaluation systems, personnel training and development systems, success planning systems and human force planning systems (Reda 2010).

(Marmi, 2010) sees human resources information systems as systems which can be corrected to perform the human resources management task and strive basically to provide the required information needed by personnel managers to take decisions related to personnel performance and check their performance effectively and raise the level of personnel performance working in the organization and hence contributing to achieving organizational objectives.

(Soria and Milod 2009:p91) define human resources information systems as (a system which works to acquire, store, restore, process, analyze and spread useful information related basically to operating human resources). It is also defined as (one of the special application

for electronic information bases and ready made programs aimed at achieving efficiency and effectiveness). It is defined and was defined by Elmagrabi (2012) as the system designed with certain functions within the frame of operations of the organization for human element tool. Specifically, undertaking the management job of human resources and seeking essentially to provide the information needed by human resources managers to take the decision related to efficiency and effectiveness of using human element. Such systems lead to development of level of performance to contribute to achieving organizational goals.

Some studies stressed that human resources information systems contribute largely to achieving organization goals and performing the works with less time and effort and least cost through the focusing on all human resources related matters. In addition, the more attention given to human resources management positions starting from recruiting and employment up to end of work bonuses, the longer the workers shall stay and get more experience and efficiency which will increase their production and in turn increase the organization production (Fergli,2007),(salah,2015), (Elzaanin,2007).

Moreover, many studies were directed at identifying dimensions of human resources information systems and the nature of its effect on organizational variables. Some of these studies included (Elmershdi 2014), (Elaanzi 2012), (Bader 2012) and (Zawi milod 2010) as they showed that there are four dimensions to human resource information systems which these studies approved them as basic standard dimensions to interpret them accurately which included the following dimensions:

Monitoring Jobs and Wages

Human resources information systems provides important advantages to the user among which the monitoring of jobs and job hierarchy in addition to the wages very accurately and fast. Organization generally pay interest to defining the value and relative importance of each job and its wage and class and defining jobs wages. Organizations also are careful about sound management of wage system (Soria and milod 2009) and help basically to achieve good and sound monitoring of recruitment, leaves, penalties, transferring, monitoring job candidates and keeping full record of personnel in a special database including also all incidents related to the employment process such as tests and personal interviews with them (2002).

Organizing Personnel Data

Human resources information systems is a mechanical system which collects, stores and extracts private information of the personnel through the making of a database including all data related to the personnel. Human resources information systems enables the used to organize personnel data with high efficiency as it contributes basically to accurately providing information to the upper management in the organization to assist in the decision-making process which is the most important advantages of those systems in organizing and managing personnel data (Elmohamed 2009).

Fast Information Restoring

Human resources information systems provides high ability of dealing with information requested by the uses or the upper management in the organization with ultra speed to restore any information related to the employee through the research function of information systems. For example, those systems help in restore all information of job applicants like the qualifications, name, age, experience. It is very important to note that fast restoration of the information leads to coordination and compatibility with other systems inside the organization to insure good work flow and dispose of any traffic. Within the organization,

they are used in stages which require speed in exchanging information during these stage and to distribute the roles and energies so as not to have any accumulation in one stage and hence the work chain would break (Eltai &Elfadl 2006).

Monitoring and Evaluating Attendance

Monitoring employees presence and absence is one of the most important matters concerning human resources management and which prevents chaos of attendance during working hours as such systems help in registering checking and leaving time with high accuracy (Supizet 2000). In addition, these human resources information systems assist human resources manager in defining working hours and leaves in according with nature of work of the organization and setting an accurate system to insure work efficiency in parallel with leaves granted to the employee (Elhusaina 2006).

OBJECTIVES OF THE STUDY

The study aims basically to verify the validity of the organizational commitment factor as latent factor by convergent validity testing known as average variance extract (AVE) for each dimension of the basic scale including (emotional commitment, continuous commitment, standard commitment) and the paragraphs which they represent , and to also verify the validity of variance known as covariance (Sv) between the dimension to be depended upon in making the association and affecting tests with other latent factors.

METHODOLOGY

Study Society and Sample

The study society is made of the decision makers (division chief, unit manager, department manager,) in the general electricity company of Libya and its branches in Libya who are about (1100) employees as (590) individual were defined as primary sample for analysis, whereas the sample fit for analysis was (565) questionnaire all of which fulfilled analysis conditions.

Tool of the Research

The researchers designed a questionnaire to test the construct validity of the human resources information system factor by depending on previous studies like (Elmurshedi 2014) (Zawi and Milod 2010) (Elgadi 2012) (Rohna 2013) (Naji and others 2011) (Elgrdahji 2013) (Elumri 2009) (Aburahma 2005) (Elaanzi 2012), as the first dimension (monitoring jobs and wages) included (6) paragraphs and like the second dimension (organizing personnel data) included (3) paragraphs. The third dimension (fast information restore) had (4) paragraphs whereas the fourth dimension (monitoring and evaluating attendance) had (4) paragraphs making for the total of (17) paragraphs, for human resources information systems scale after verifying its external validity (arbitration) through presentation to specialized professors in this field and to verify validity of reliability coefficient by Alpha Cronbach test.

Confirmatory Factor Analysis-CFA

The researchers used confirmatory factor analysis for all parts and components of the measurement tool to verify the construct validity of the study questionnaire according to its main dimensions (monitoring jobs and wages, organizing personnel data, fast information restore, monitoring and evaluating attendance) by depending on Fornell –Larcker criterion in addition to four main indicators to test its credibility like: 1) Chi-square and degrees of freedom,2) chi square (Cmin/df) so that it shall be ($5 \leq df/2x \geq 2$) (marsh and hocevar ,1985),

and 3) (CFI) indicator higher than 0.90 (Mackdonald and Marsh,1990) 4) (RMSEA) less than 0.08 (Browne and Cudeck 1993).

RESULTS

The results of indicators test for conformity and suitability of the scale of human resources information systems (before modification):

The confirmatory factor analysis results as in figure (1) for human resources information system scale and its four dimensions showed that it is free of any (illogical correlation) which reaches or exceeds the number (1), and that confirms to us that there is no problem in the confirmatory analysis of human resources information system scale with four main dimensions: (monitoring jobs and wages, organizing personnel data, fast information restore, monitoring and evaluating attendance). And even though the scale is free of any illegal correlation, however, some of its main indicators do have some nonconformance and that is clear from figure (1) and also table (1). And by looking into the value of Chi square, the result was (cmn/df=6.622) which is a value higher than the criterion (5) in addition to Rmsea indicator whose result was also higher than the intended one and it exceeded the set standard value and reached (Rmsea=0.100) which is higher than (0.080). and to re-describe the scale according to what was proposed by Amos program, it was required to connect some of its paragraphs and delete some as shown in figure (2).

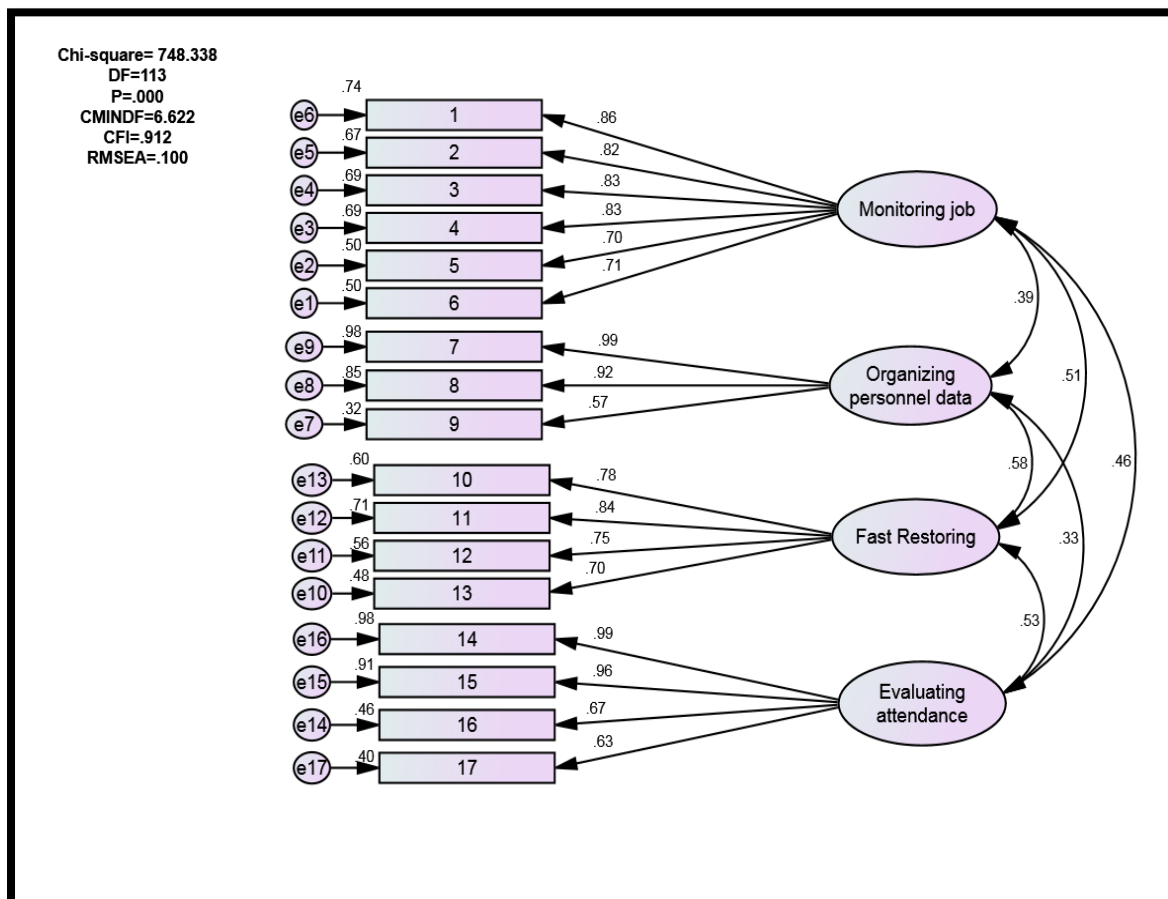

Figure 1. Confirmatory Factor analysis (Amos program) for human resources information systems scale (model before modification)

Table 1. suitability and conformance values for human resources information systems scale before and after modification

Sr. No	Conformant indicators and matching model with data collected from study environment	Indicators value before change	Indicators value after change	Value indicating quality of matching
1	chi square (Cmin)	748.338	349.282	
2	Temperature (Df)	113	93	
3	significance level (p)	0.000	0.000	non indicated
4	value of chi square (Cmin/df)	6.622	3.766	Less than (5)
5	differential matching indicator (Cfi)	0.912	0.962	More than (.900)
6	(Rmse)	0.100	0.070	Less than (.080)

Results of standard and nonstandard perimeters and transactions of human resources information systems scale (after modification)

After connecting some paragraphs and deleting other for human resources information systems scale proposed by Amos, and by looking into table (2) for the modified form, the standard and nonstandard perimeters and transactions showed that matching indicators of the model with the data were perfect with the set standards as the values of these indicators to the Chi square were (Cmin+349.282) and the temperature was (df+39) and the significance level for statistical significance (p=0.00) and value of chi square (cmin/df=3.766) and did not exceed the criterion (5) in addition to the value of the differential matching indicator was (cfi=0.962) which is higher that the criterion (0.90). the results also showed the suitability of the value of indicator of root mean square rounding error (Rmse) which was (Rmse=0.070) and less than the criterion (.080). all of those indicators prove that the human resources information system model conforms with environment of the study from which the information were collected.

And by looking into the correlations between the dimension of the human resources information systems scale as shown in figure (2) and table (2), the correlations (relations) between the dimensions of the model all had significance level as the (t)statistical value was higher than (1.964) and significance level (probability value) is equal to (p=0.000) and was less than criterion (0.05).

Also , the correlation ratios between the dimensions in the model ranged between (0.47) as least correlation ratio and was after monitoring the job and evaluating the attendance. Whereas after the organization of personnel data and after fast information restore correlated by (70%) as highest correlation percentage between the dimensions. This also indicates that the dimensions had (discriminant validity) as all correlation went away from total melting between them and declined in its correlation from the total melting set at (0.90). The next table shows the standard and nonstandard perimeters and transactions and correlations and common variance between the dimensions of the modified human resources information systems model.

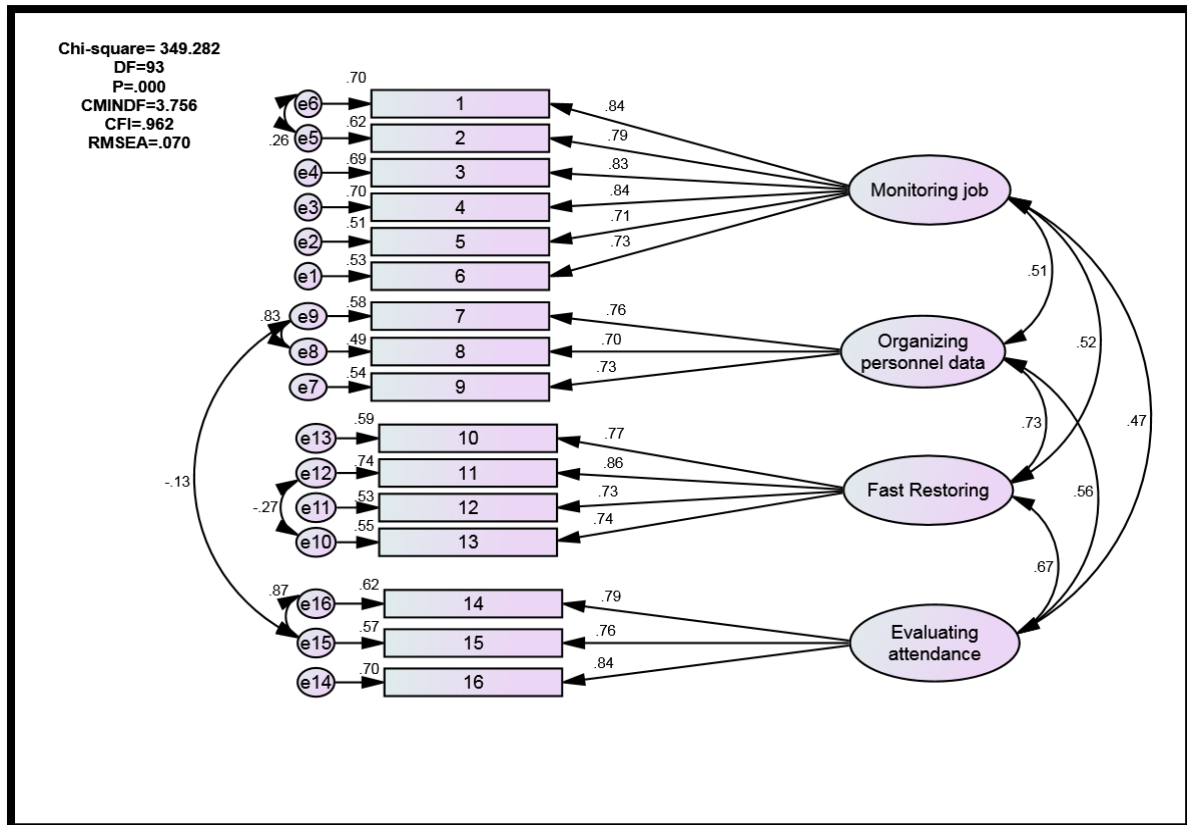

Figure 2. Confirmatory factor analysis (Amos program) for human resources information systems scale (model after modification)

Table 2. Unrated values and (T) value and significance level and correlation values between dimensions of human resources information systems.

Sr. No	Latent factor	correlation	Latent factor	Estimate	Se	C R	P	R	SV
				Unrated Estimate	Scale error	Critical ratio (T)	Function level	correlation	Common variance
1	Monitoring job	↔	Organizing information	0.603	0.072	8.076	0.000	0.51	0.26
2	Monitoring job	↔	Fast restoring	0.648	0.072	7.782	0.000	0.52	0.27
3	Monitoring job	↔	evaluating attendance	0.450	0.060	8.147	0.000	0.47	0.22
4	Organizing Data	↔	Fast restoring	0.695	0.078	10.019	0.000	0.73	0.53
5	Organizing data	↔	evaluating attendance	0.475	0.064	8.505	0.000	0.56	0.31
6	Fast restoring	↔	evaluating attendance	0.483	0.063	10.221	0.000	0.67	0.45

Results of construct validity test for first dimension (monitoring job and salary) for human resources information systems scale:

By looking at figure (2) and table (3) we clearly find that saturation or correlation between first dimension (monitoring job and salary) and its representing six paragraphs had statistical significance level as the (T) statistical value for each paragraph was higher than (1.964) and the significance level (probability value) less than (0.001). The saturation ratio was high and excellent and higher than the intended value (0.50) as it ranged from (0.71) paragraph (5) and

(0.84) in paragraph (1). Which is known as (loading factor) for the dimension of monitoring job and salary. also, the multiple correlation square (MCS) ratios ranged between (0.51) to (0.70). the mean for MCS called (AVE) which must be at least (0.50) as one of the basic criterion for convergent validity. And from the same table (3) we find that the mean variance extracted was (0.63). All of these indicators show that the dimension with convergent validity proofs and as a one dimension of the human resources information systems.

Table 3. Estimate unrated and (T) value, significance level and saturation and correlation ratio and mean variance extracted for the dimension of monitoring job and salary.

Sr. No.	Para. No	Latent factor	Estimate	S.E	C.R	P	Loading	SMC	AVE
			Unrated estimates	Scale error	(T) value	Function level	saturation	Square correlation	Extracted variance
1	Para.1	Organizing information	1.000				0.84	0.70	0.63
2	Para.2	Organizing information	0.932	0.037	25.286	0.000	0.79	0.62	
3	Para.3	Organizing information	0.972	0.42	23.114	0.000	0.83	0.69	
4	Para.4	Organizing information	0.938	0.4	23.307	0.000	.084	0.70	
5	Para.5	Organizing information	0.794	0.42	18.743	0.000	0.71	0.51	
6	Para. 6	Organizing information	0.815	0.42	19.247	0.000	0.73	0.53	

Results of construct validity test for second dimension (organizing personnel data) for human resources information systems

By looking at figure (2) and table (4) we clearly that saturation or correlation between first dimension (monitoring job and salary) and its representing six paragraphs had statistical significance level as the (T) statistical value for each paragraph was higher than (1.964) and the significance level (probability value) less than (0.001). The saturation ratio was high and excellent and higher than the intended value (0.50) as it ranged from (0.70) paragraph (8) and (0.76) in paragraph (7) which confirms the convergent validity (sv) for the dimension of organizing personnel data. Also, the multiple correlation square (MCS) ratios ranged between (0.49) to (0.58). the mean for MCS called (AVE) which must be at least (0.50) as one of the basic criterion for convergent validity. And from the same table (4) we find that the mean variance extracted was (0.64). All of these indicators show that the dimension with convergent validity proofs and as a one dimension of the human resources information systems.

Table 4. Unrated values and (T) value and significance level and saturation and square correlation ratio and mean variance extracted for the dimension of organizing personnel data

Sr. No	Para. No	Latent factor	Estimate	S.E	C.R	P	Loading	SMC	AVE
			Unrated estimates	Scale error	(T) value	Function level	saturation	Square correlation	Extracted variance
1	Para.7	Organizing personnel data	1.000				0.76	0.58	0.54
2	Para. 8	Organizing personnel data	0.946	0.26	35.963	0.000	0.0	0.49	
3	Para. 9	Organizing personnel data	0.906	0.67	13.600	0.000	0.73	0.54	

Results of construct validity test for third dimension(fast information restoring) for human resources information systems

By looking at figure (2) and table (5) we clearly that saturation or correlation between first dimension (monitoring job and salary) and it representing six paragraphs had statistical significance level as the (T) statistical value for each paragraph was higher than (1.964) and the significance level (probability value) less than (0.001). The saturation ratio was high and excellent and higher than the intended value (0.50) as it ranged from (0.73) paragraph (12) and (0.86) in paragraph (11) which confirms the convergent validity (cv) for the dimension of standard commitment dimension. Which confirms the convergent validity (cv) for the dimension of organizing personnel data. Also, the multiple correlation square (MCS) ratios ranged between (0.49) to (0.58). The mean for MCS called (AVE) which must be at least (0.50) as one of the basic criterion for convergent validity. And from the same table (5) we find that the mean variance extracted was (0.60). All of these indicators show that the dimension with convergent validity proofs and as a one dimension of the human resources information systems.

Table 5. Unrated values and (T) value and significance level and saturation and square correlation ratio and mean variance extracted for the dimension of fast information restore

Sr. No.	Para. No	Latent factor	Estimate	S.E	C.R	P	Loading	SMC	AVE
			Unrated estimates	Scale error	(T) value	Function level	saturation	Square correlation	Extracted variance
1	Par. 10	Fast restoring	0.951	0.47	20.06	0.000	0.77	0.59	0.60
2	Para.11	Fast restoring	1.000				0.86	0.74	
3	Para.12	Fast restoring	0.845	0.45	18.792	0.000	0.73	0.53	
4	Para.13	Fast restoring	0.819	0.47	17.598	0.000	74.00	0.55	

Results of construct validity test for fourth dimension (fast information restoring) for human resources information systems

By looking at figure (2) and table (6) we clearly that saturation or correlation between first dimension (monitoring job and salary) and it representing six paragraphs had statistical significance level as the (T) statistical value for each paragraph was higher than (1.964) and the significance level (probability value) less than (0.001). The saturation ratio was high and excellent and higher than the intended value (0.50) as it ranged from (0.76) paragraph (15) and (0.84) in paragraph (16) which confirms the convergent validity (cv) for the dimension of standard commitment dimension. which confirms the convergent validity (cv) for the dimension of organizing personnel data. Also, the multiple correlation square (MCS) ratios ranged between (0.57) to (0.70). the mean for MCS called (AVE) which must be at least (0.50) as one of the basic criterion for convergent validity. And from the same table (5) we find that the mean variance extracted was (0.63). All of these indicators show that the dimension with convergent validity proofs and as a one dimension of the human resources information systems.

Table 6. Unrated values and (T) value and significance level and saturation and square correlation ratio and mean variance extracted for the dimension of monitoring attendance evaluating

Sr. No.	Para. No	Latent factor	Estimate	S.E	C.R	P	Loading	SMC	AVE
			Unrated estimates	Scale error	(T) value	Function level	saturation	Square correlation	Extracted variance
1	Para.14	Monitoring attendance evaluating	0.927	0.60	15.529	0.000	0.79	0.62	0.63
2	Para.15	Monitoring attendance evaluating	0.866	0.59	14.984	0.000	0.76	0.57	
3	Para.16	Monitoring attendance evaluating	1.0000				0.84	0.70	

Results of Fornell-Larcker Criterion for human resources information systems

To verify predictive validity (variance) between the dimensions of human resources information systems scale, the researchers applied Fornel-Larcker criterion so that the average variance (AVE) extracted for each dimension in the criterion shall be higher that the common variance (cv) for all relations and correlations. Table (7) shows correlations between the four dimensions of the human resources information systems scale.

Table 7. Correlation matrix between the four dimensions for human resources information systems scale

Sr. No.	Latent variables	Monitoring jobs and wages	Organizing personnel data	Fast restoring	Monitoring attendance evaluating
1	Monitoring jobs and wages	1			
2	Organizing personnel data	0.51	1		
3	Fast restoring	0.52	0.73	1	
4	Monitoring attendance evaluating	0.47	0.56	0.67	1

We see from table (8) which shows to us the common variance between the four dimensions which is the outcome of multiplying the correlation by itself. And from the same table which shows the average variance extracted (ave) which was higher than the common variance (sv) between all dimensions and that indicates that the human resources information systems model has fulfilled the Fornell –Larcker criterion and was characterized by variance validity between its four dimension.

Table 8. Common variance matrix and variance extracted between the four dimensions of human resources information systems scale

Sr. No.	Latent variables	Monitoring jobs and wages	Organizing personnel data	Fast restoring	Monitoring attendance evaluating
1	Monitoring jobs and wages	0.63			
2	Organizing personnel data	0.26	0.54		
3	Fast restoring	0.27	0.53	0.60	
4	Monitoring attendance evaluating	0.55	0.31	0.45	0.63

CONCLUSION AND DISCUSSION

This scientific paper has achieved its main goal of study which is verification of validity of building human resources information systems scale at the general electricity company of Libya through the use of confirmatory factor analysis (CFA) as one of the modeling techniques for construct equation (SEM-AMOS), as it was depended on the basic measuring dimensions for latent factor (human resources information systems) and some scientific studies such as (Elmurshedi 2014) and (Zawi & Milod 2010) and (Elgadi 2012) and (Elrohna 2013) and (Elgardahji 2013) and Elumri 2009) and (Aburahma 2005) and (Elanzi 2013). The results indicated the hypothetic model and the criterion set for it in addition to validity of constructing it as measuring tool which can be depended upon in measuring human resources information systems inside industrial companies. The scale also was characterized with its approximate validity (AVE) between measuring dimensions and main indicators as they were all over the set criterion (0.50). The study also proved the variance validity between the main scale dimensions for measuring human resources information systems (organizing wages, organizing personnel data, fast information restore, monitoring attendance) as the average variance extracted for all dimensions paragraphs was higher than the common variance between them (sv) and this result came out perfectly conformant with Fornell-Larcker criterion.

Therefore, we conclude that the human resources information systems scale can be depended upon as a dependable measuring tool in implementing correlation studies in the future.

REFERENCES

- [1] Aburahma, A. I. (2005). *Human resources information systems and its effect on efficiency of personnel management in national Palestine power ministries in Gaza strip* (Masters study in business management). Gaza, Palestine: Islamic university.
- [2] Elhusaina, S. (2006). *Administrative information systems* (Vol. 4). Amman: Waraq publishing and distribution institution.
- [3] Elrawahna, A. A. (2013). *Effect of human resources quality electronic management e-hrm on personnel performance efficiency, case study in Jordan communication group/orange* (Masters study in electronic business management). Jordan: Middle East University.
- [4] Zawi, S., & Lomi, M. (2010). *The role of human resources information systems in evaluating human resources performance in the institution*. Sukra, Algeria: Mohamed Haidar University.
- [5] Elzaanin, A. A. A. (2007). *Effect of transformation in accounting IT systems* (Master's thesis). Gaza: Islamic university.
- [6] Salah, A. S. A. (2015). *Effect of use of information systems on human resources performance and organization performance: Empirical study at the general electricity company of Libya* (Unpublished PhD study). Nilay: Malaysian Islamic Sciences University.
- [7] Eltai, Y., & Moaid, E. (2006). *Human resources management, complete strategic approach* (Vol. 1). Amman: Waraq hall.

- [8] Omar, I. A. (2002). *Integrated information system in managing national social security board in Egypt and how other entities benefit from such information*. Azhar University: Social security's conference.
- [9] Elumar, A. A. I. (2009). *Effect of accounting management IT systems on personnel performance in the palestencial telecommunication company*. Gaza: Islamic University.
- [10] Elanzi, A. (2012). *Management information systems*. Saudi Arabia: Mohamed ben Saud Islamic University.
- [11] Fargali, A. A. (2007). *Information systems and its role in traditional and electronic marketing* (Vol. 1). Cairo: Itrak publishing and distribution.
- [12] Elgadi, Z. (2012). *Relationship between strategic human resources practices and personnel performance and their effect on organization performance*. Jordan: Middle East University.
- [13] Elgardhaji, M. M. (2013). *Effect of human resources management processes effect on organization intelligence*. Jordan: Middle East University.
- [14] Elmahamad M. E. (2014). *Human resources management systems*. Syria: Damascus University.
- [15] Elmurshdi, K. A. (2014). *Effect of application of human resources management on personnel performance in Saudi Arabian higher educational institutions*. Saudi Arabia: Second conference for general management and administrative development institutions in the gulf cooperation council.
- [16] Marmi, M. (2010). *Importance of management IT systems as an environmental analysis tool in small and medium enterprises in Algeria*. Algeria: Stif University.
- [17] Elmagrabe, A. (2002). *Management information systems: Principles and standards* (Vol. 1). Egypt: Modern library.
- [18] Naji, A., Aldik, M., & Elgat, A. (2011). *Extent of effect of management information systems on quality of management decision making in Palestinian mobile company*. Palestine: National Najah University.
- [19] Rida, H. H. (2010). *Development and building human resources systems* (Vol. 1). Amman: Raia publishing and distribution hall.
- [20] Bader, Y. O. (2010). *The relationship between Human Resources Information System (HRIS) functions and Human Resources Management (HRM) functionalities*. *Journal of Management Research*, 4 (4).
- [21] Browne, M.W., & Cudek, R. (1993). *Alternative ways of assessing model fit*. London: Sage focus editions.
- [22] McDonal, R. P., & Marsh, H. E., (1990). *Choosing a multivariate model: Non-centrality goodness of fit*. *Psychological Bulletin*, 107 (2), 247-255.
- [23] Marsh, H.W., & Hocevar, D. (1985). *Application of confirmatory factor analysis to the study of self-concept: First and higher order factor models and their invariance across groups*. *Psychological Bulletin*, 97 (3), 562-585.